

7 Szenen und Texte

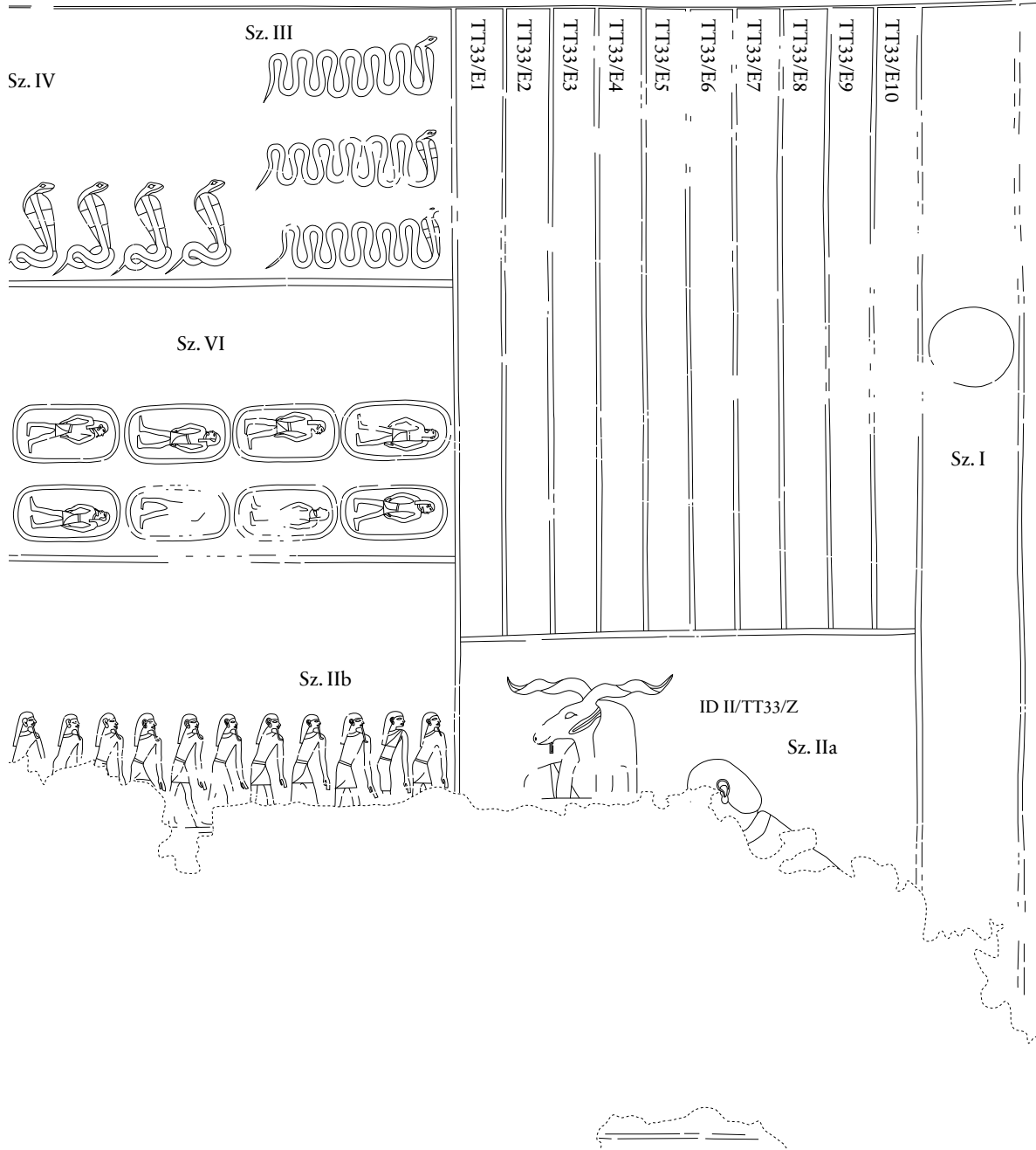

Hb. II/TT33/E, Hb. Sz. II (DOI 10.17171/2-8-177)

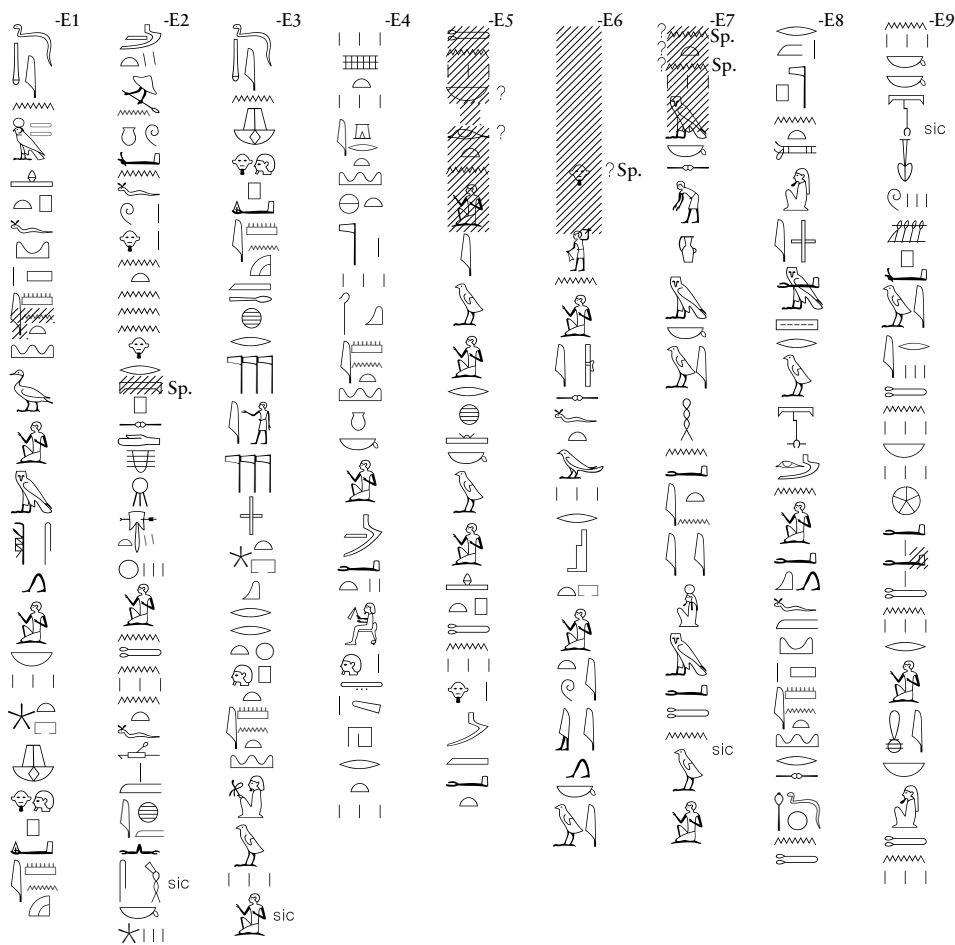

Eine Umzeichnung von Text II/TT33/E ist abgedruckt in Daniel A. Werning. „Following the Sun God into the Netherworld. The Chief Lector Priest Petamenophis in the Footsteps of a Pharaoh“ (zur Veröffentlichung angenommen).

II/TT33/Z



*)  dazwischen gezwängt.

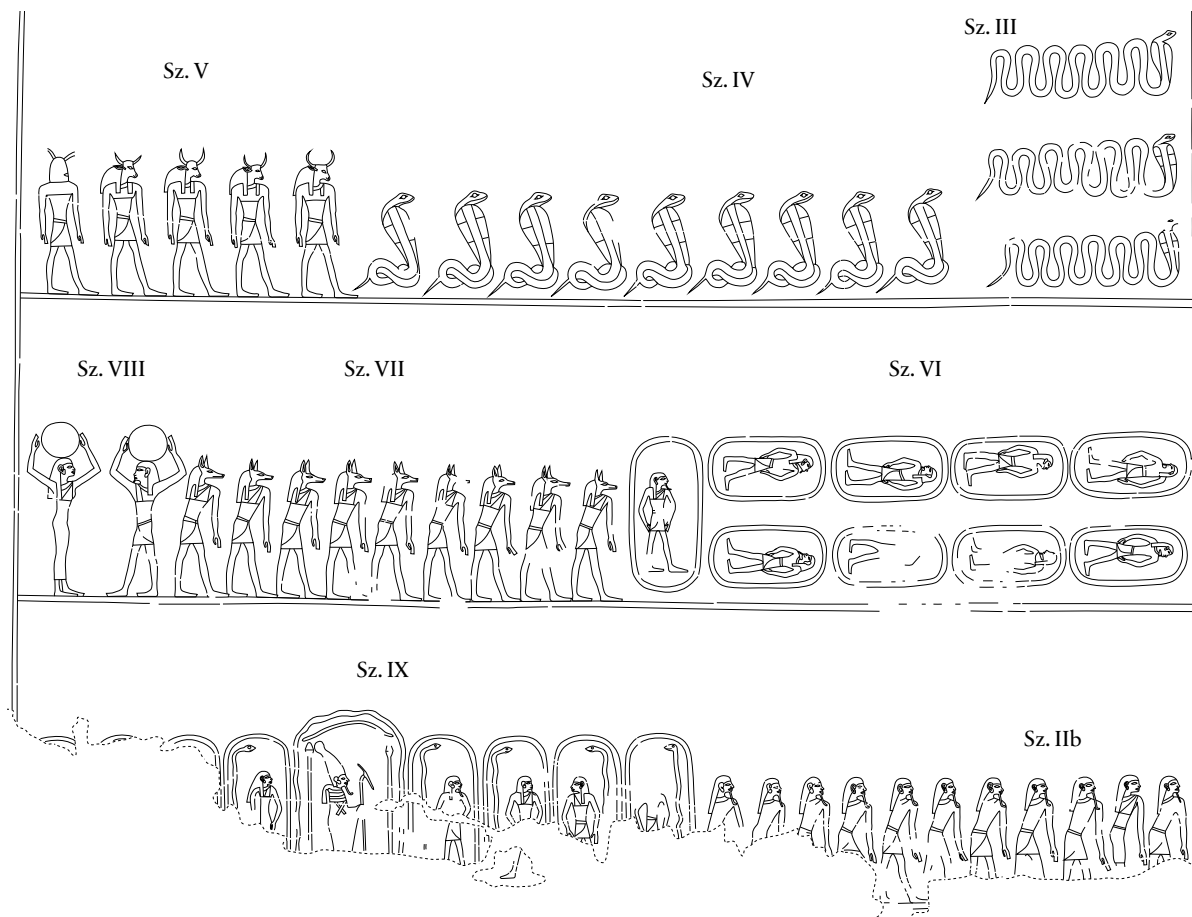

1 - Hb. 1	
2 - Hb. 1	
3 - Hb. 1	
4 - Hb. 1-2a	
5 - Hb. 2a	
6 - Hb. 2a-2b	
7 - Hb. 2b-2c	
8 - Hb. 2c	
9 - Hb. 2c-3	
10 - Hb. 3-4	
11 - Hb. 4	
12 - Hb. 4-5	
13 - Hb. 5-6	
14 - Hb. 6-7	
15 - Hb. 7-8	
16 - Hb. 8-9	
17 - Hb. 9	
18 - Hb. 9	
19 - Hb. 10	
20 - Hb. 10	
21 - Hb. 10	
22 - Hb. 10	
23 - Hb. 10	
24 - Hb. 10-12	
25 - Hb. 12-13	
26 - Hb. 13	
27 - Hb. 13-14	
28 - Hb. 14	
29 - Hb. 14-15	
30 - Hb. 15	
31 - Hb. 15	
32 - Hb. 15	

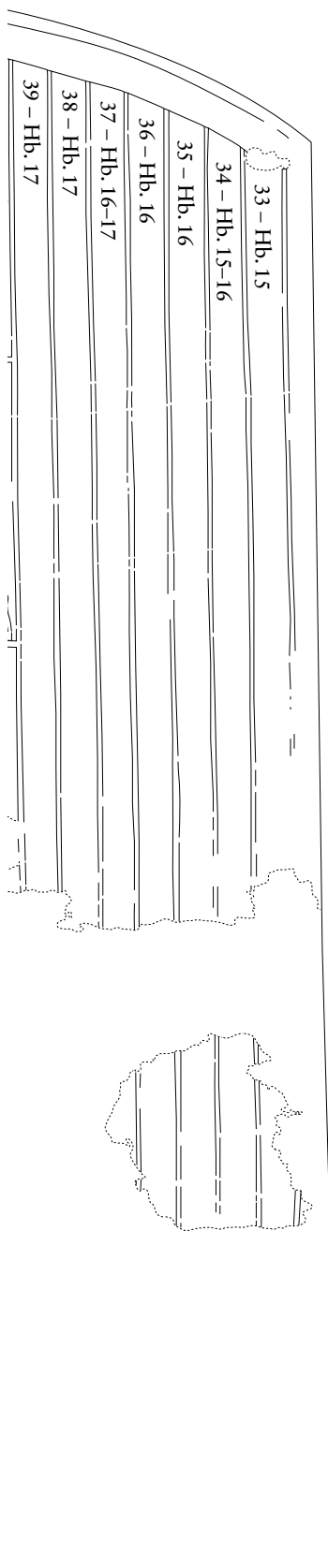

Hb. 1 (DOI 10.17171/2-8-74)

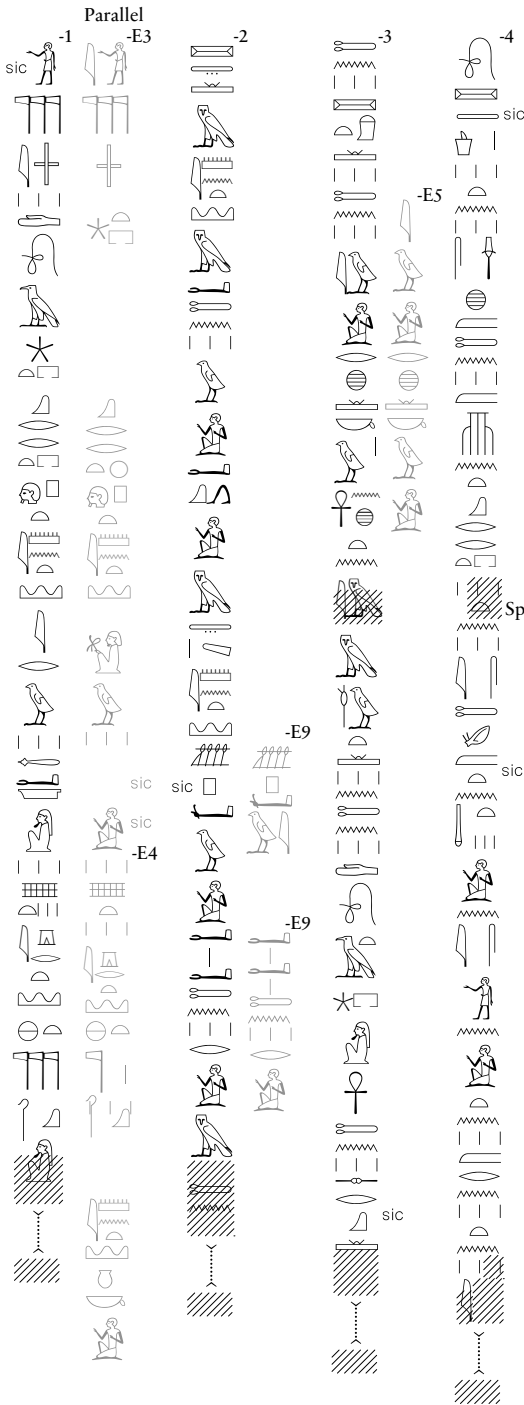

Hb. 2 (DOI 10.17171/2-8-75)

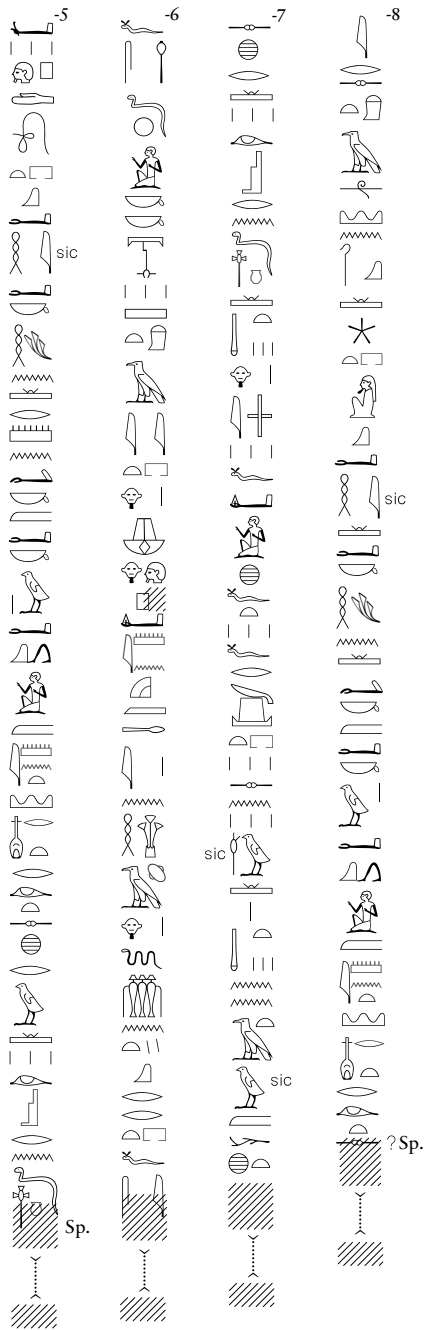

Hb. 3
(DOI 10.17171/2-8-76)

Hb. 4
(DOI 10.17171/2-8-77)

Hb. 5
(DOI 10.17171/2-8-78)

Hb. 6-7
(DOI 10.17171/2-8-80)

Hb. 8
(DOI 10.17171/2-8-81)

Hb. 9
(DOI 10.17171/2-8-82)

9

sic

10

sic

11

sic
Sp.

12

sic

13

sic

14

sic

15

sic

16

sic

17

sic

Hb. 10
(DOI 10.17171/2-8-83)



-18

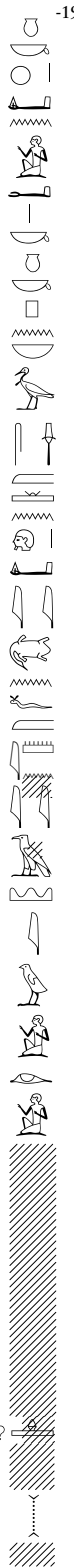

-19

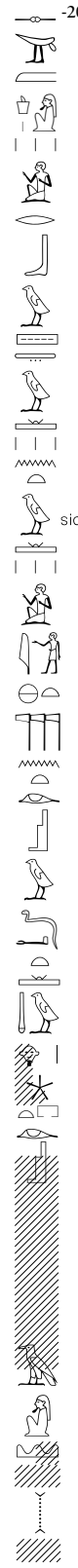

-20



-21



-22

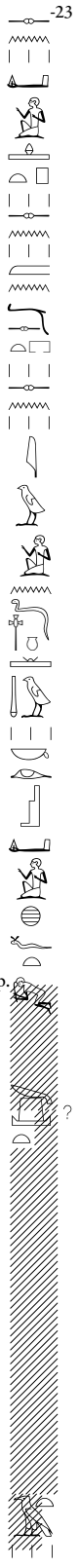

-23

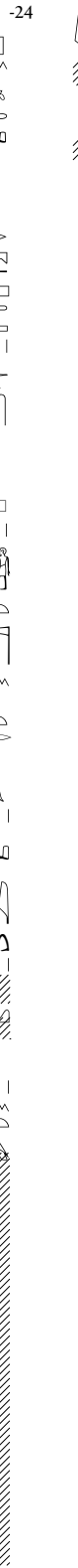

-24



Hb. 11
(DOI 10.17171/2-8-83)

Hb. 12-13 (DOI 10.17171/2-8-85)

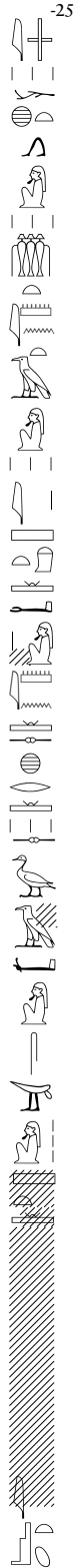
-25

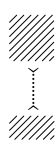
 A vertical column of hieroglyphs starting with a seated figure, followed by various symbols including birds, lotus flowers, and a seated figure. The column ends with a hatched area.



-26

 A vertical column of hieroglyphs starting with a seated figure, followed by various symbols including birds, lotus flowers, and a seated figure. The column ends with a hatched area.

Hb. 14 (DOI 10.17171/2-8-86)

-27

 A vertical column of hieroglyphs starting with a seated figure, followed by various symbols including birds, lotus flowers, and a seated figure. The column ends with a hatched area.

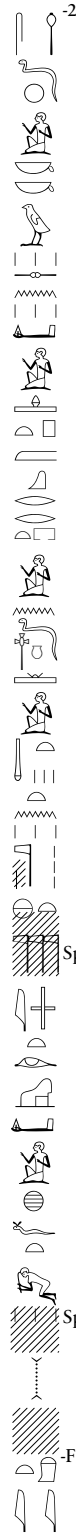
-28

 A vertical column of hieroglyphs starting with a seated figure, followed by various symbols including birds, lotus flowers, and a seated figure. The column ends with a hatched area.

-29

 A vertical column of hieroglyphs starting with a seated figure, followed by various symbols including birds, lotus flowers, and a seated figure. The column ends with a hatched area.

-30

 A vertical column of hieroglyphs starting with a seated figure, followed by various symbols including birds, lotus flowers, and a seated figure. The column ends with a hatched area.

-31

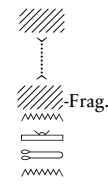
 A vertical column of hieroglyphs starting with a seated figure, followed by various symbols including birds, lotus flowers, and a seated figure. The column ends with a hatched area.



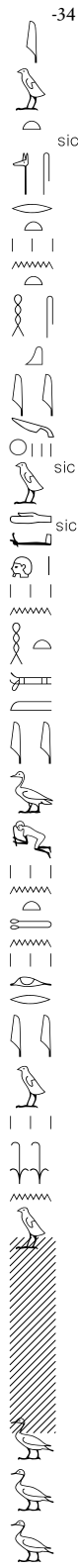
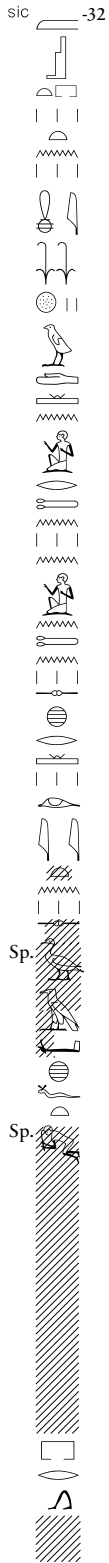

Hb. 17 (DOI 10.17171/2-8-89)



-37





-38



-39



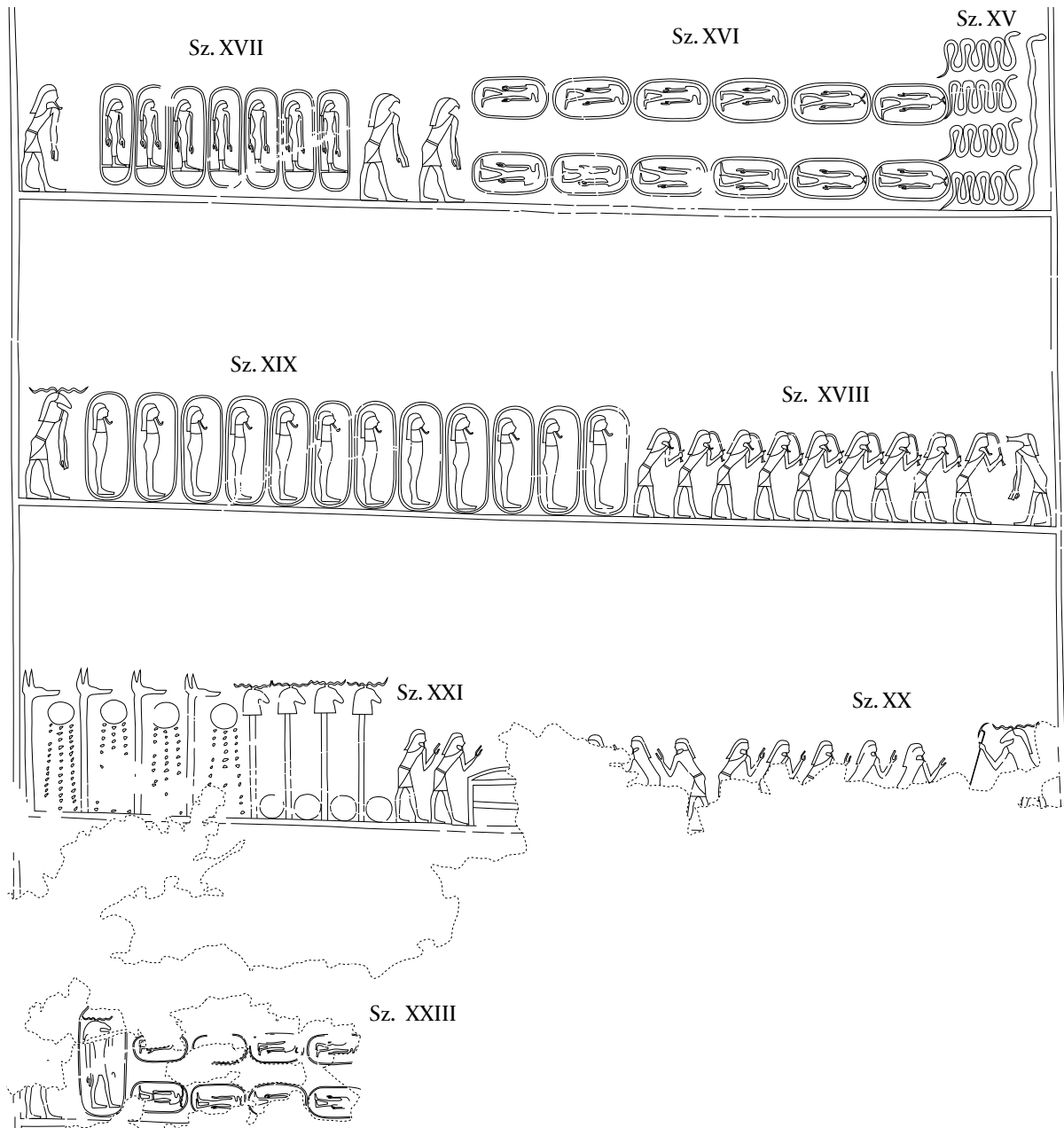

40 - Hb. 18	
41 - Hb. 18-18 (Anrufung 1)	
42 - Hb. 18	
43 - Hb. 18 (Anrufung 2)	45 - Hb. 18 (Anrufung 4)
44 - Hb. 18 (Anrufung 3)	46 - Hb. 18
47 - Hb. 18	
48 - Hb. 18	
49 - Hb. 18-19	
50 - Hb. 19	

31 - Hb. 19	
32 - Hb. 19	
33 - Hb. 19	
34 - Hb. 19	
35 - Hb. 19	
36 - Hb. 19	
37 - Hb. 19	
38 - Hb. 20 (Anrufung 1)	63 - Hb. 20 (Anrufung 6)
39 - Hb. 20 (Anrufung 2)	64 - Hb. 20 (Anrufung 7)
40 - Hb. 20 (Anrufung 3)	65 - Hb. 20 (Anrufung 8)
41 - Hb. 20 (Anrufung 4)	66 - Hb. 20
42 - Hb. 20 (Anrufung 5)	67 - Hb. 20
43 - Hb. 20	
44 - Hb. 20	
45 - Hb. 20	
46 - Hb. 20	
47 - Hb. 20	
48 - Hb. 20	
49 - Hb. 20	
50 - Hb. 20	
51 - Hb. 20	
52 - Hb. 20	
53 - Hb. 20	
54 - Hb. 20	
55 - Hb. 20	
56 - Hb. 20	
57 - Hb. 20	
58 - Hb. 20	
59 - Hb. 20	
60 - Hb. 20	
61 - Hb. 20	
62 - Hb. 20	
63 - Hb. 20	
64 - Hb. 20	
65 - Hb. 20	
66 - Hb. 20	
67 - Hb. 20	
68 - Hb. 20	
69 - Hb. 20	
70 - Hb. 20	
71 - Hb. 20	
72 - Hb. 20	
73 - Hb. 20	
74 - Hb. 20	
75 - Hb. 20	
76 - Hb. 20	
77 - Hb. 20	
78 - Hb. 20	
79 - Hb. 20	
80 - Hb. 20	
81 - Hb. 20	
82 - Hb. 20	
83 - Hb. 20	
84 - Hb. 20	
85 - Hb. 20	
86 - Hb. 20	
87 - Hb. 20	
88 - Hb. 20	
89 - Hb. 20	
90 - Hb. 20	
91 - Hb. 20-22	

91 - Hb. 21-22			
92 - Hb. 22			
93 - Hb. 22			
94 - Hb. 22		101 - Hb. 22 (Anrufung 7)	107 - Hb. 22
95 - Hb. 22 (Anrufung 1)		102 - Hb. 22 (Anrufung 8)	108 - Hb. 22
96 - Hb. 22 (Anrufung 2)		103 - Hb. 22 (Anrufung 9)	109 - Hb. 22
97 - Hb. 22 (Anrufung 3)		104 - Hb. 22 (Anrufung 10)	110 - Hb. 22
98 - Hb. 22 (Anrufung 4)		105 - Hb. 22 (Anrufung 11)	111 - Hb. 22
99 - Hb. 22 (Anrufung 5)		106 - Hb. 22 (Anrufung 12)	112 - Hb. 22
100 - Hb. 22 (Anrufung 6)		113 - Hb. 22	
114 - Hb. 22			
115 - Hb. 22-23			
116 - Hb. 23-24			
117 - Hb. 24			
118 - Hb. 24-24 (Anrufung 1)			
119 - Hb. 24 (Anrufung 1)		121 - Hb. 24 (Anrufung 3)	123 - Hb. 24
120 - Hb. 24 (Anrufung 2)		122 - Hb. 24 (Anrufung 4)	124 - Hb. 24
125 - Hb. 24			
126 - Hb. 24			
127 - Hb. 24			
128 - Hb. 24-25			

128 – Hb. 24-25			
129 – Hb. 25			
130 – Hb. 25 (Anrufung 1)	145 – Hb. 26 (Anrufung 1)		[145bis]
131 – Hb. 25 (Anrufung 2)	146 – Hb. 26 (Anrufung 2)		[146bis]
132 – Hb. 25 (Anrufung 3)	147 – Hb. 26 (Anrufung 3)		[147bis]
133 – Hb. 25 (Anrufung 4)	148 – Hb. 26 (Anrufung 4)		[148bis]
134 – Hb. 25 (Anrufung 5)	149 – Hb. 26 (Anrufung 5)		[149bis]
135 – Hb. 25 (Anrufung 6)	150 – Hb. 26 (Anrufung 6)		[150bis]
136 – Hb. 25 (Anrufung 7)	151 – Hb. 26 (Anrufung 7)		[151bis]
137 – Hb. 25 (Anrufung 8)	152 – Hb. 26 (Anrufung 8)		[152bis]
138 – Hb. 25 (Anrufung 9)	153 – Hb. 26		[153bis]
139 – Hb. 25 (Anrufung 10)	154 – Hb. 26		[154bis]
140 – Hb. 25 (Anrufung 11)	155 – Hb. 26		[155bis]
141 – Hb. 25 (Anrufung 12)		[156]	[156bis]
142 – Hb. 25		[157]	[157bis]
143 – Hb. 25		[158]	[158bis]
144 – Hb. 25		[159]	[159bis]
160 – Hb. 28			
161 – Hb. 28-29			
162 – Hb. 29			
163 – Hb. 29			
164 – Hb. 29			
165 – Hb. 29			
166 – Hb. 29			
167 – Hb. 29			

40 



41  Sp.
sic

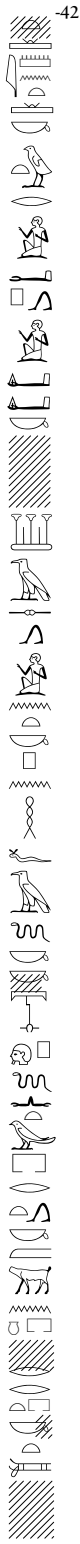

42 



43 

44 

45 

Hb. 19 (DOI 10.17171/2-8-91)

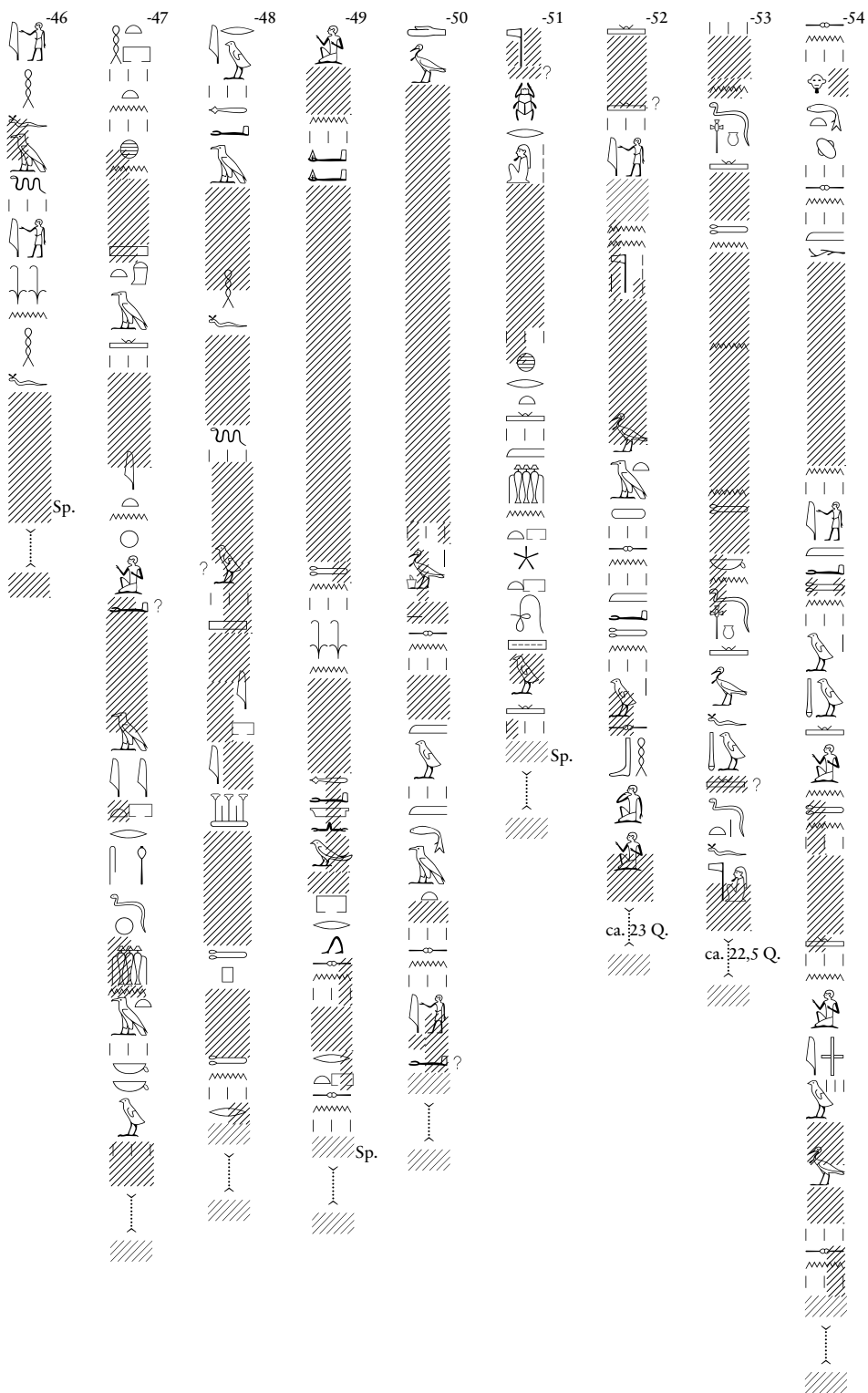



ca. 10,5 Q.



ca. 9 Q.

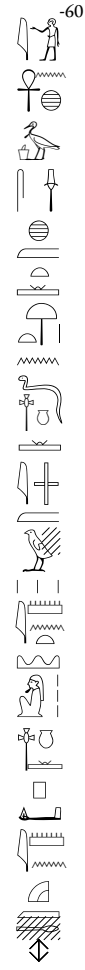

-61

 Hieroglyphic line 61, starting with a seated figure and ending with a double-headed arrow.

-62

 Hieroglyphic line 62, starting with a seated figure and ending with a double-headed arrow. A 'sic' label is placed above the middle of the line.

-63

 Hieroglyphic line 63, starting with a seated figure and ending with a double-headed arrow. The bottom half of the line is filled with diagonal hatching.

-64

 Hieroglyphic line 64, starting with a seated figure and ending with a double-headed arrow. The bottom half of the line is filled with diagonal hatching.

-65

 Hieroglyphic line 65, starting with a seated figure and ending with a double-headed arrow. The bottom half of the line is filled with diagonal hatching.

-66

 Hieroglyphic line 66, starting with a seated figure and ending with a double-headed arrow. The bottom half of the line is filled with diagonal hatching.

-67

 Hieroglyphic line 67, starting with a seated figure and ending with a double-headed arrow. The bottom half of the line is filled with diagonal hatching. A 'sic' label is placed above the middle of the line.

-68

 Hieroglyphic line 68, starting with a seated figure and ending with a double-headed arrow. The bottom half of the line is filled with diagonal hatching. A 'sic' label is placed above the middle of the line.

-69

 Hieroglyphic line 69, starting with a seated figure and ending with a double-headed arrow. The bottom half of the line is filled with diagonal hatching.

⁻⁷⁶

⁻⁷⁵



⁻⁷⁴







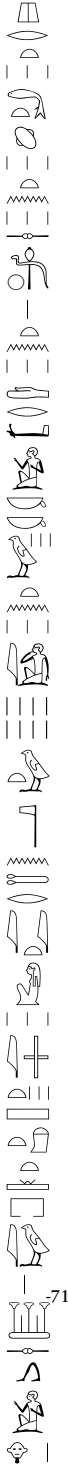



-77 sic ? ?

-78 sic ? ?

-79 ? ?

-80 sic ? ?

-81 ? ?

-82 ? ?

-83 ? ?

-84 Sp. ? Sp. ?

-85 -86 ? ?

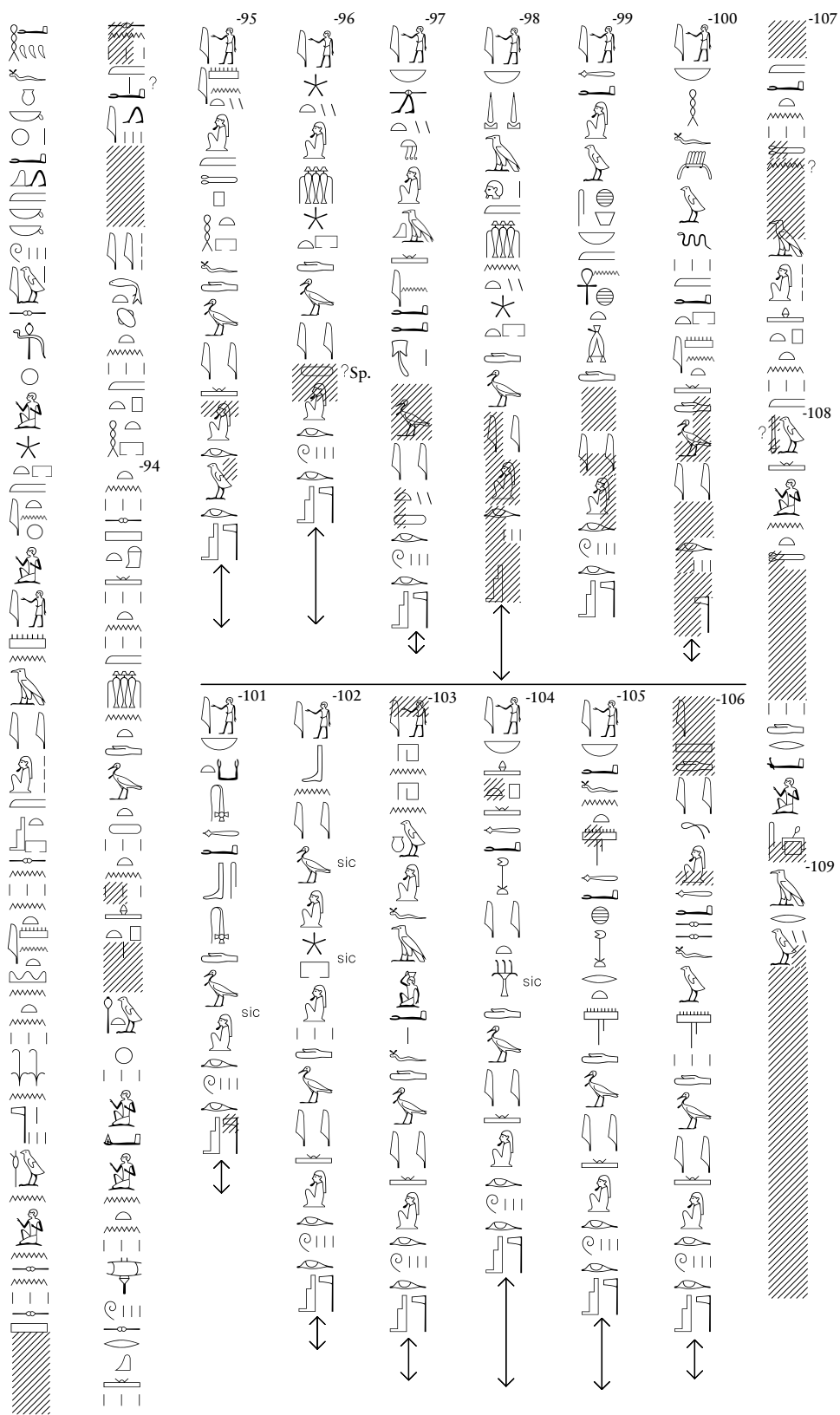

Hb. 23 (DOI 10.17171/2-8-95)

Hb. 24 (DOI 10.17171/2-8-96)

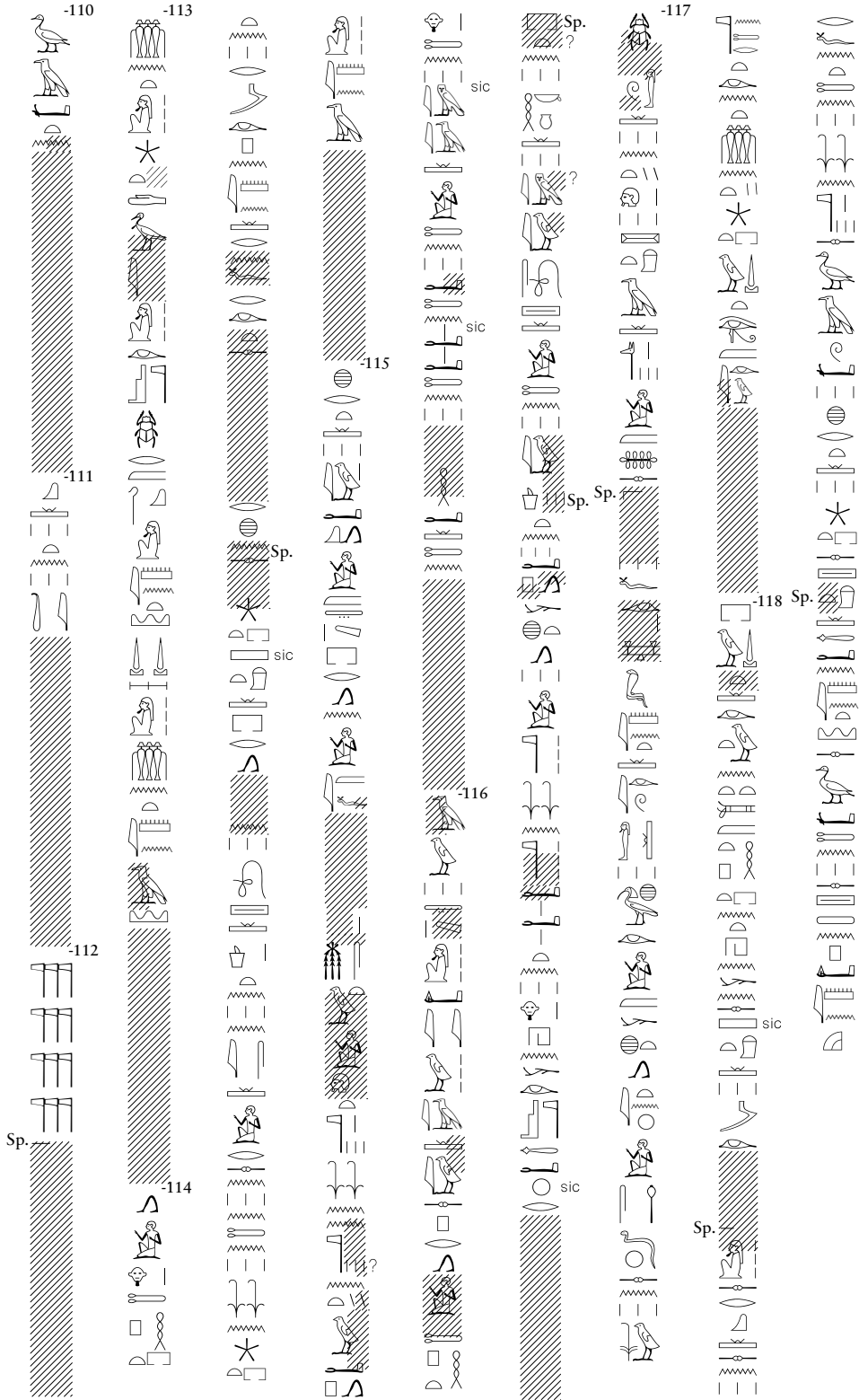



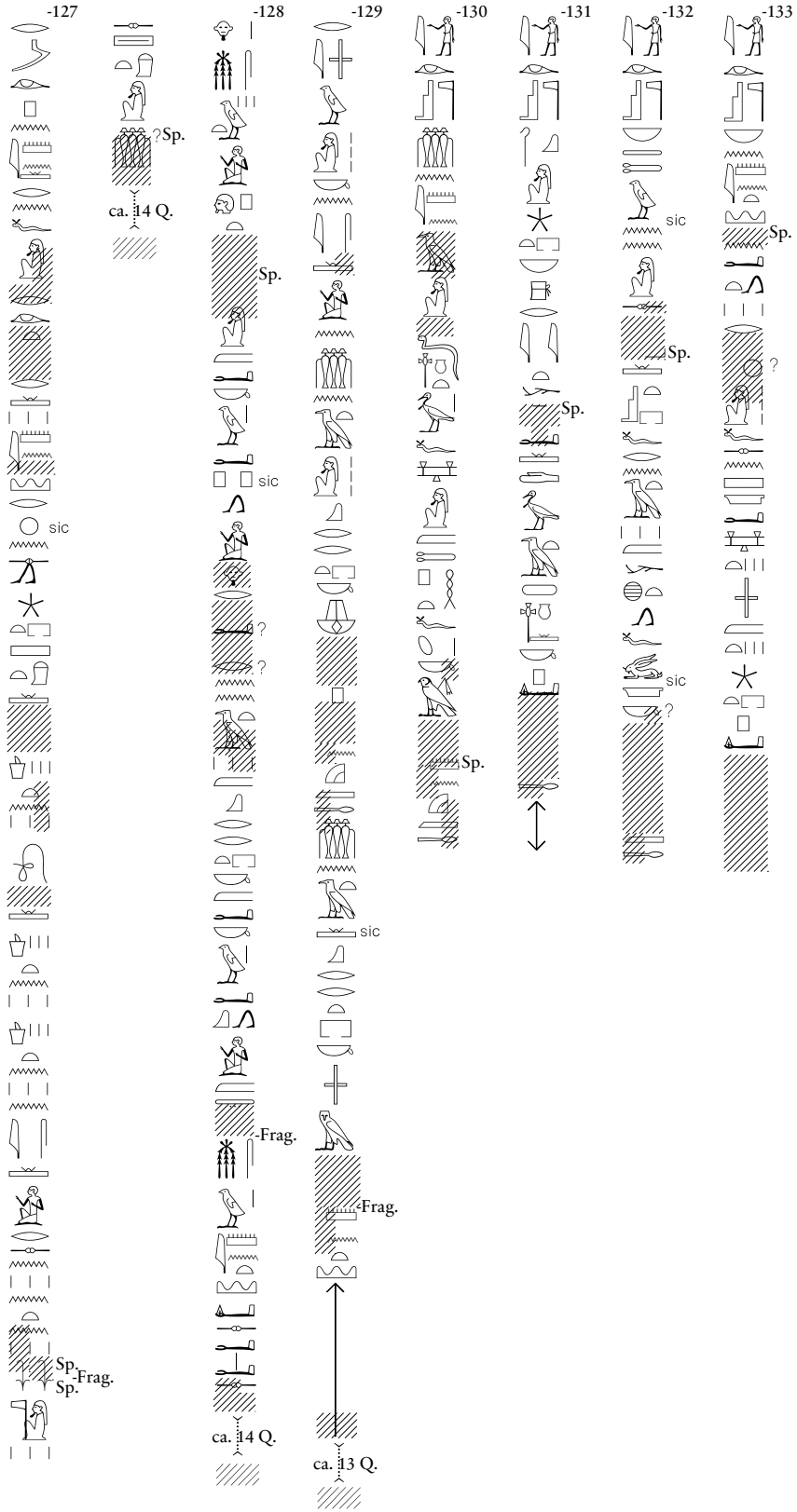

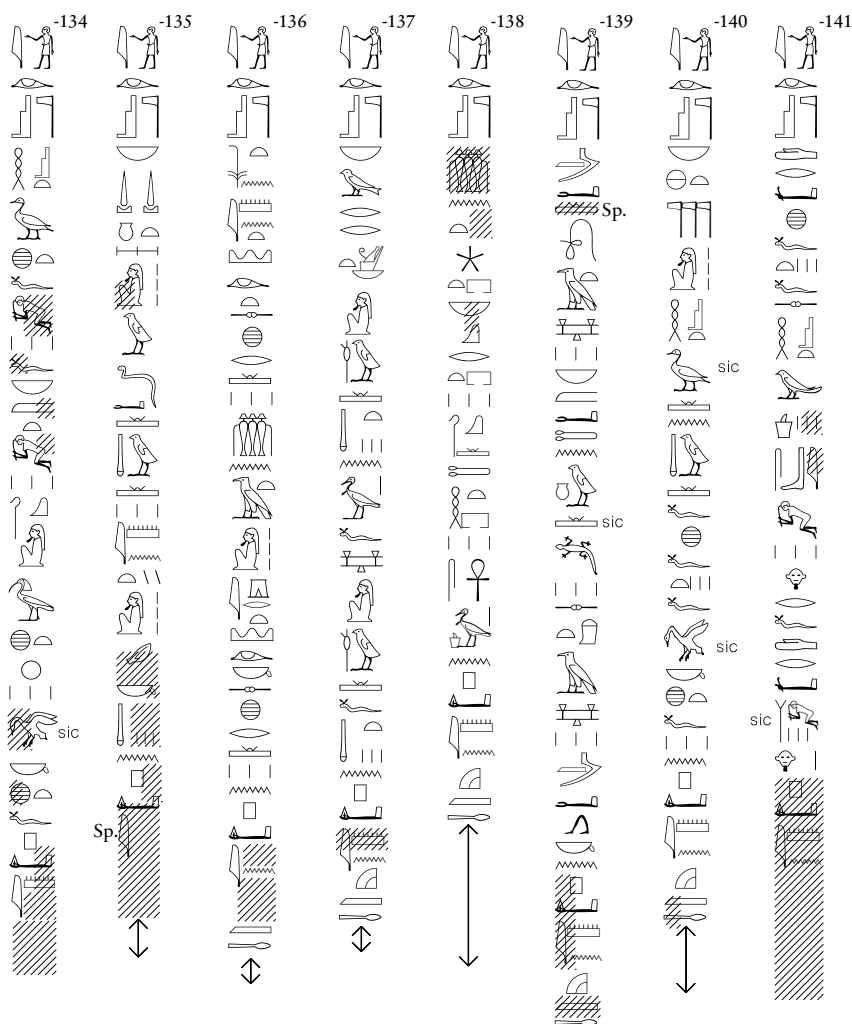

Hb. 26 (DOI 10.17171/2-8-98)

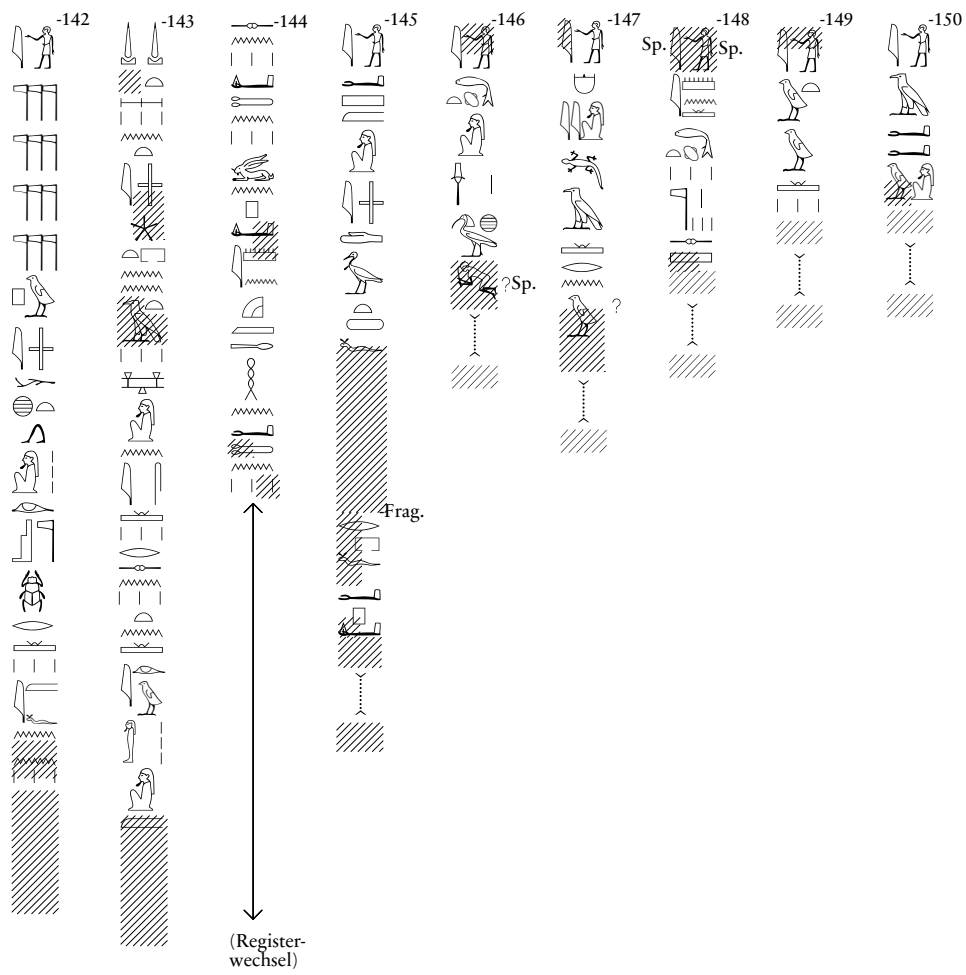

Hb. 27 (zerstört)

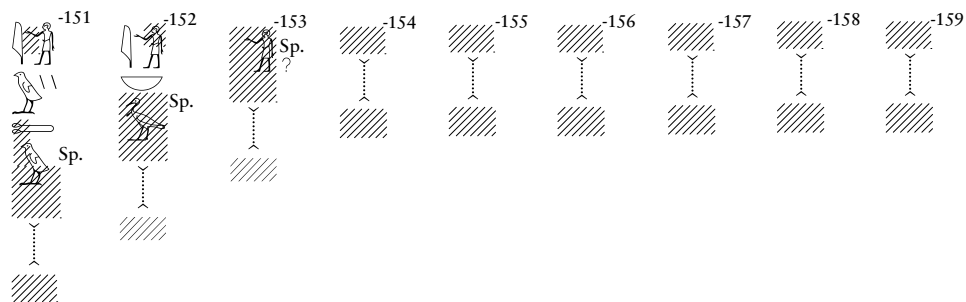

Hb. 28 (DOI 10.17171/2-8-99)

Hb. 29 (DOI 10.17171/2-8-100)

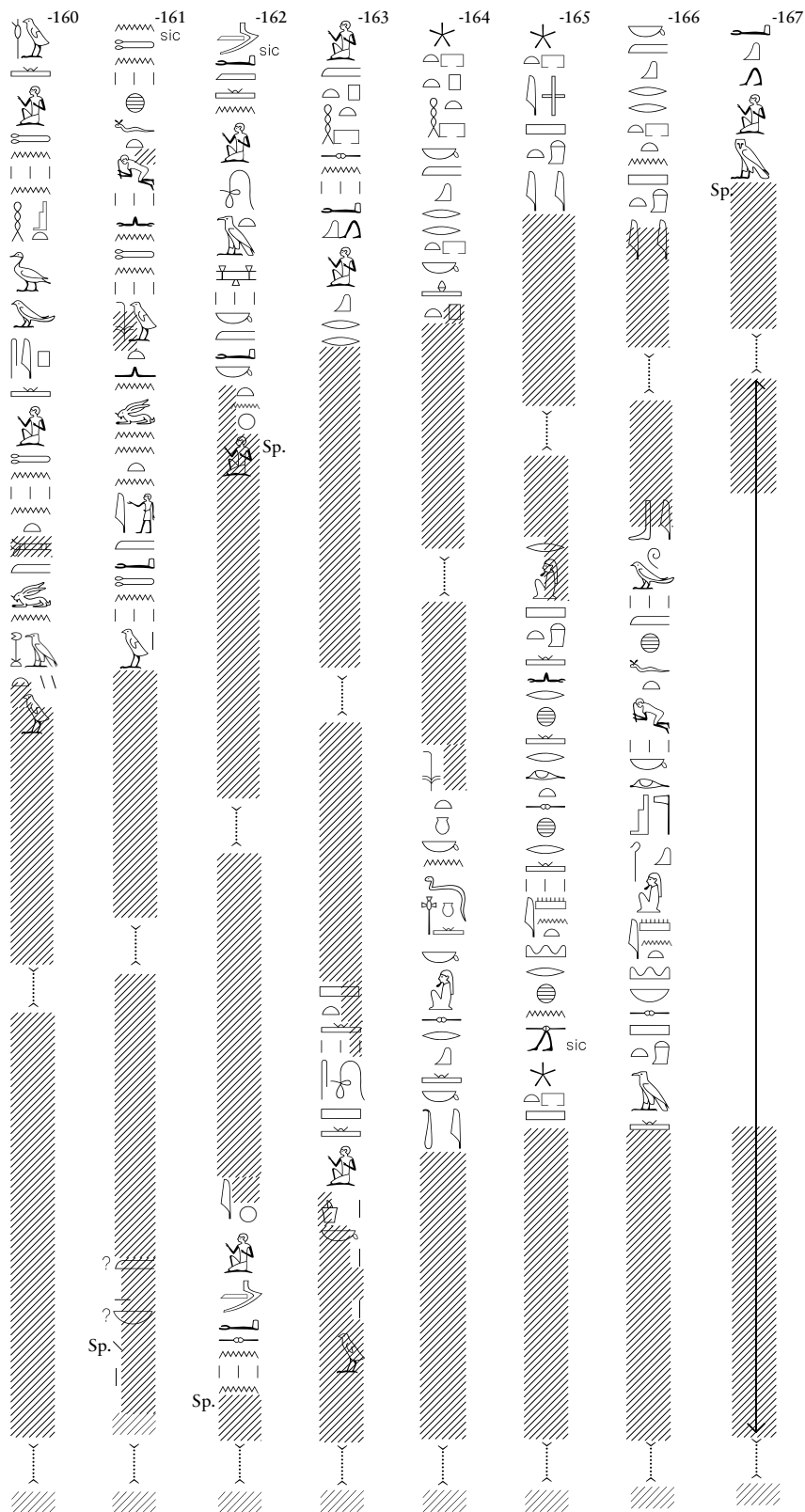

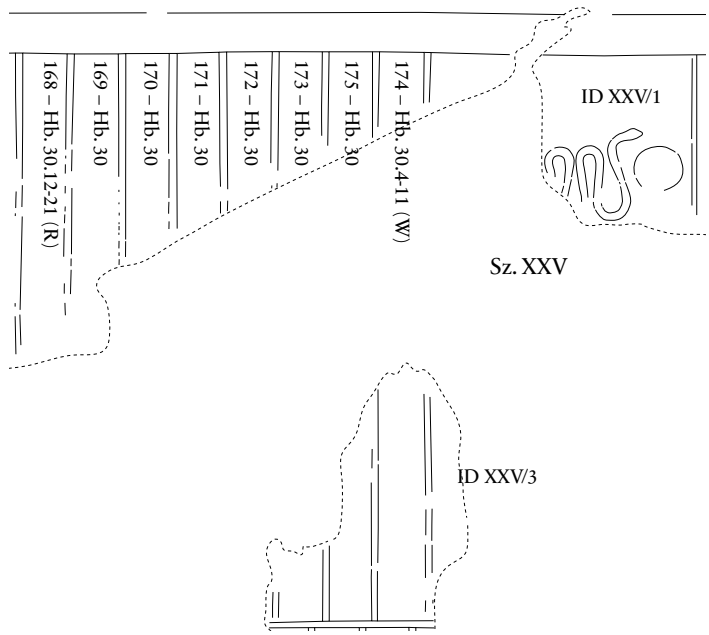

Hb. Sz. XXV (DOI 10.17171/2-8-18)

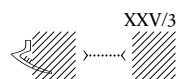

Hb. 30.4-11
(DOI 10.17171/2-8-101)

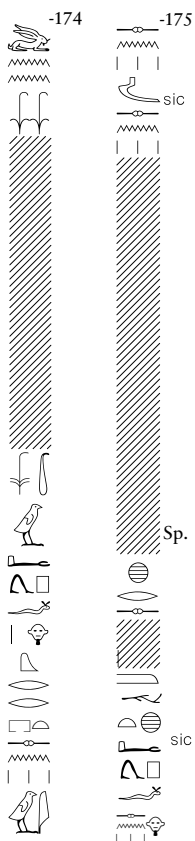

Hb. 30.12-21
(DOI 10.17171/2-8-101)

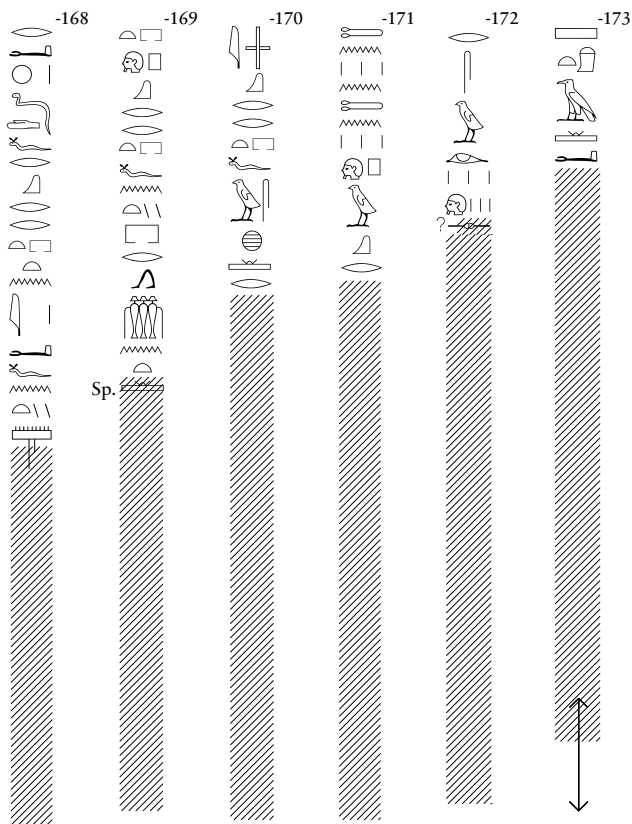

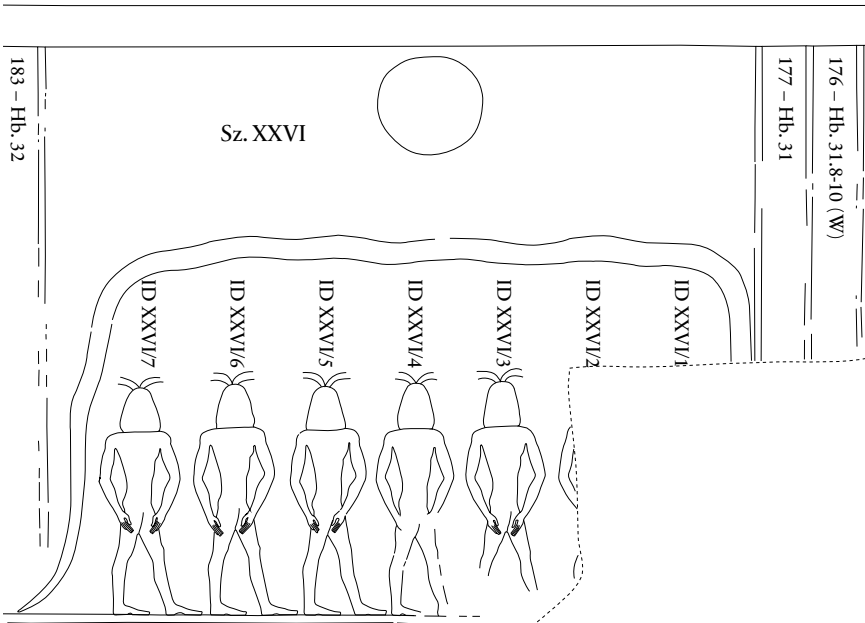

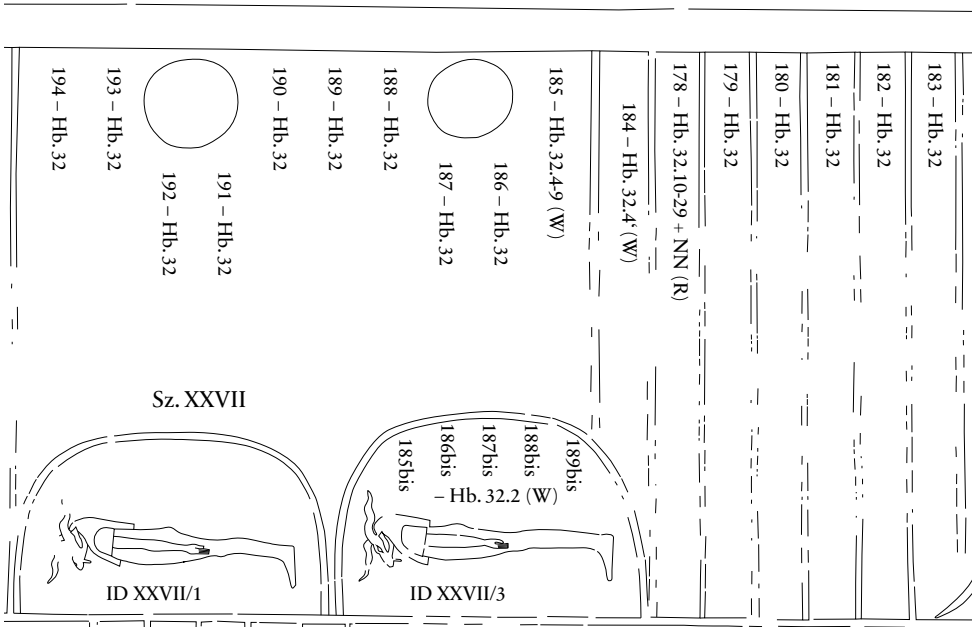

Hb. Sz. XXVII (DOI 10.17171/2-8-20)

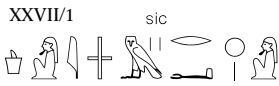

Hb. 32.4-9 (DOI 10.17171/2-8-20)

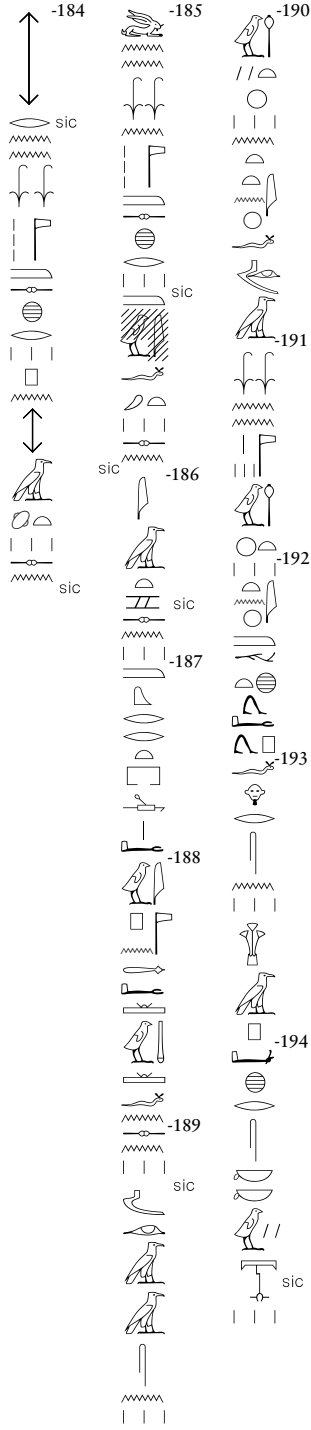

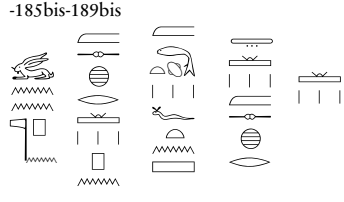

Hb. 32.2 (DOI 10.17171/2-8-20)



Hb. 32.10-29 (DOI 10.17171/2-8-103)



200 – Hb. 33			
199 – Hb. 33			
198 – Hb. 33			
197 – Hb. 33			
196 – Hb. 33			
195 – Hb. 33.4.19 (R)			
	 ID XXVIII/1	 ID XXVIII/2	 ID XXVIII/3
	Sz. XXVIII		

Hb. Sz. XXVIII (DOI 10.17171/2-8-21)

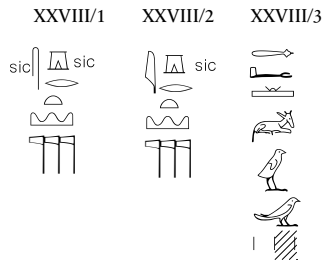

Hb. 33 (DOI 10.17171/2-8-104)

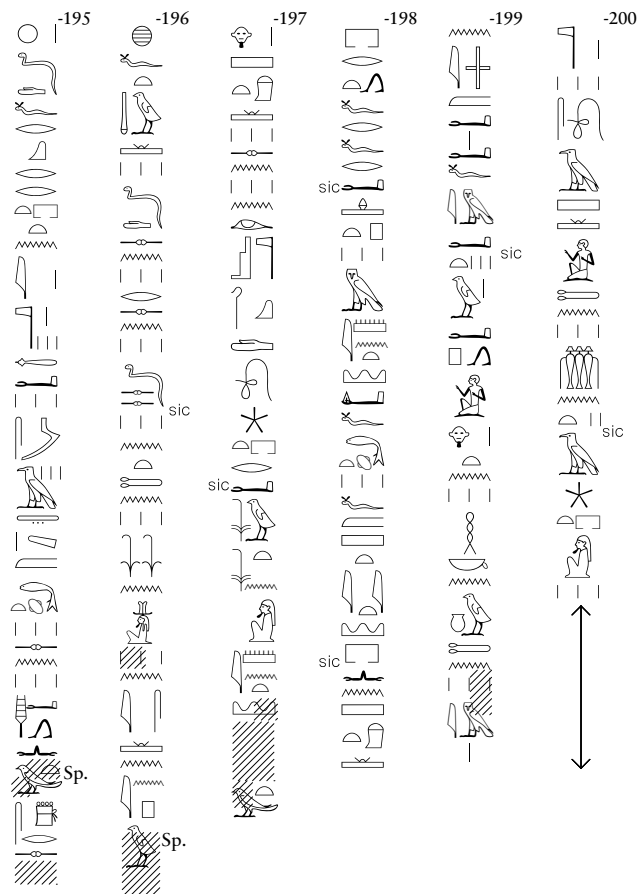

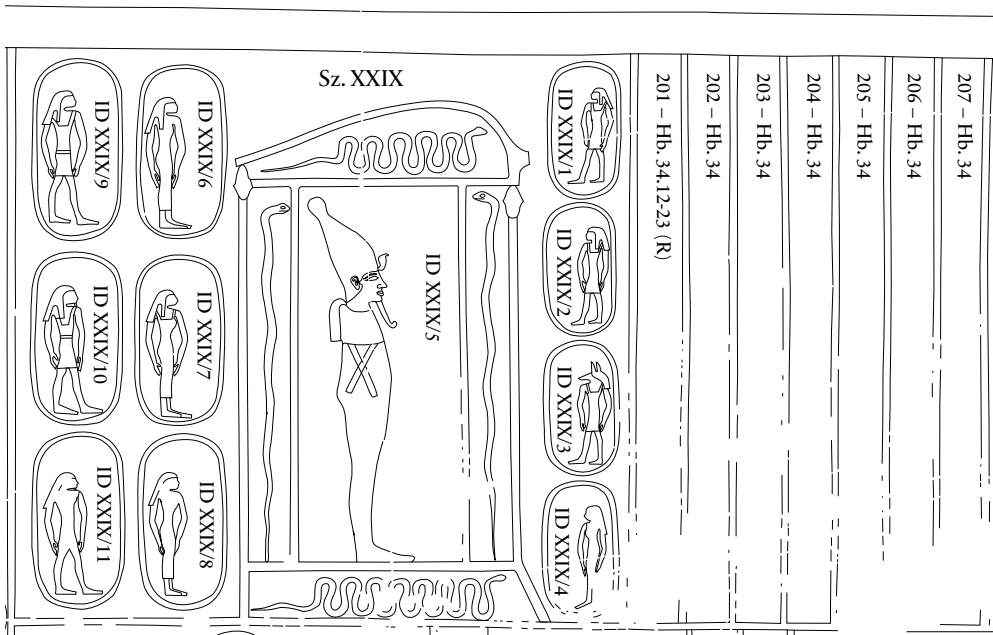

Hb. Sz. XXIX (DOI 10.17171/2-8-22)

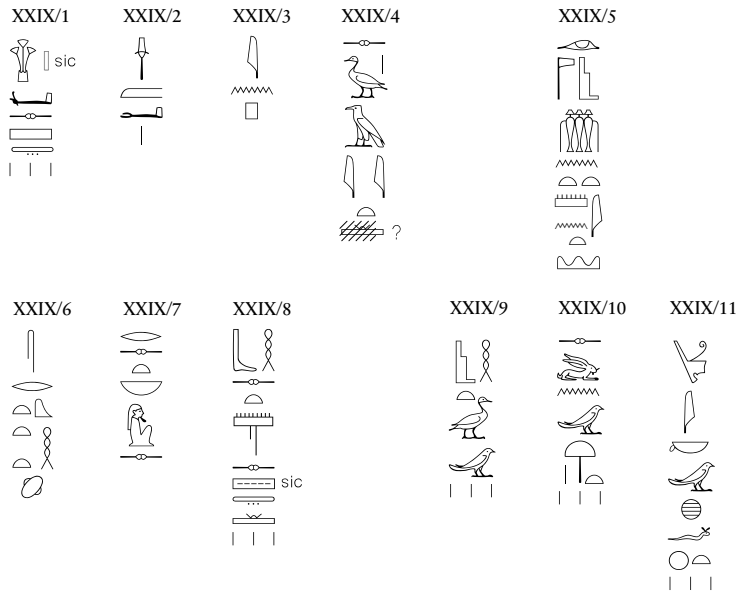

Hb. 34 (DOI 10.17171/2-8-105)

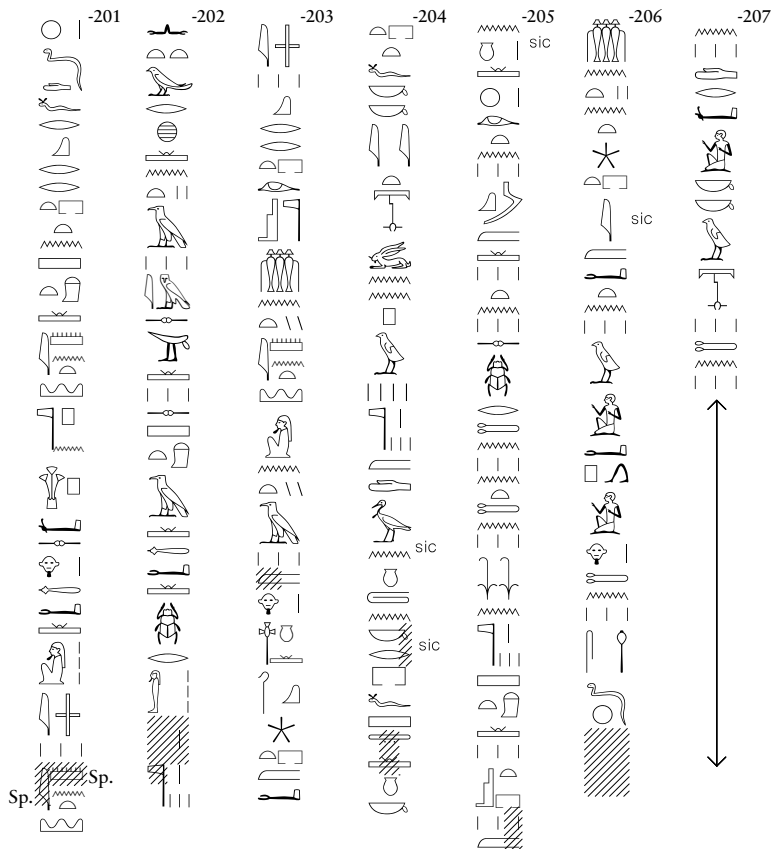

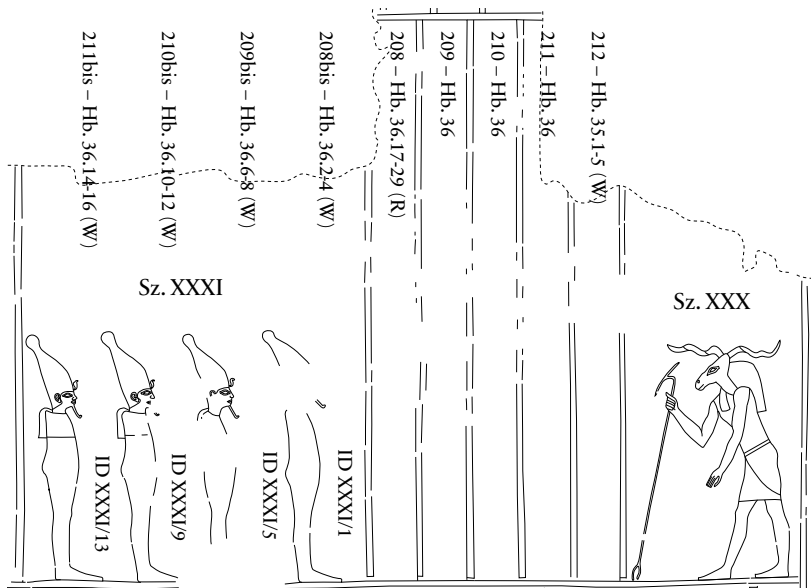

Hb. Sz. XXX-XXXI (DOI 10.17171/2-8-23)

Hb. 35
(DOI 10.17171/2-8-106)

Hb. 36
(DOI 10.17171/2-8-107)

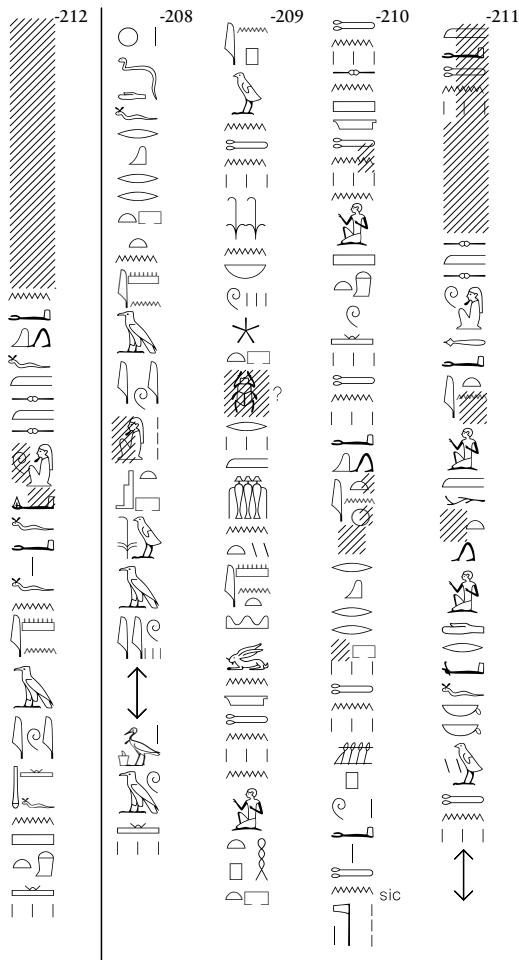

Hb. Sz. XXXI
(DOI 10.17171/2-8-24)

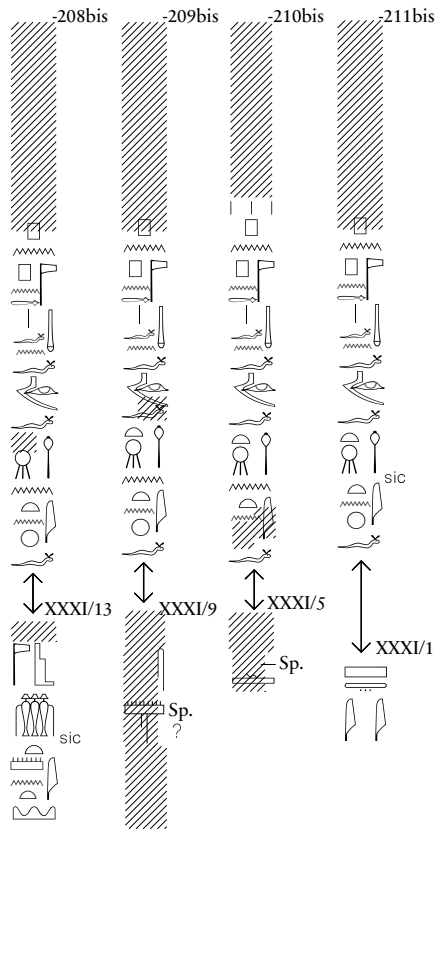

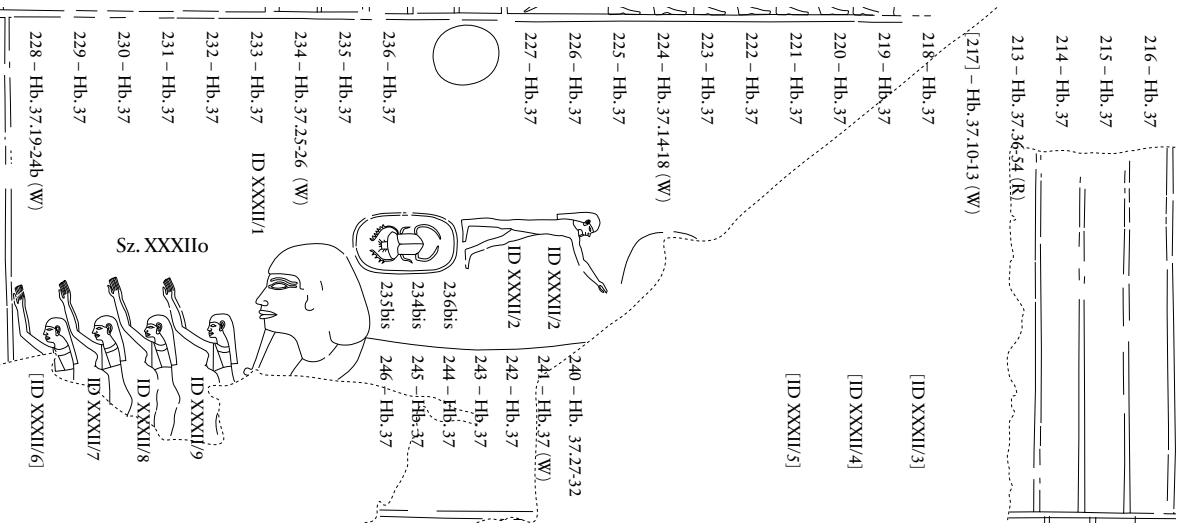

Hb. 37.36-54
(DOI 10.17171/2-8-108)

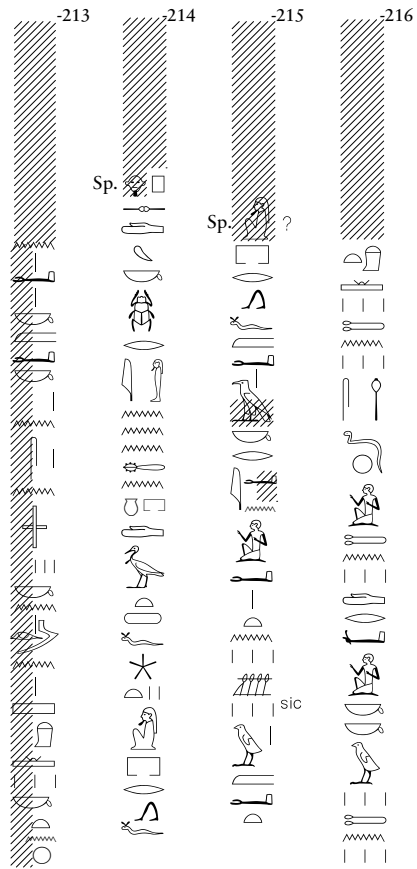

Hb. Sz. XXXII
(DOI 10.17171/2-8-25)

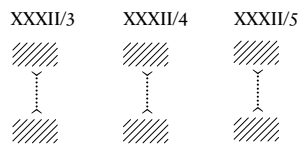

Hb. 37.10-13 (DOI 10.17171/2-8-108)

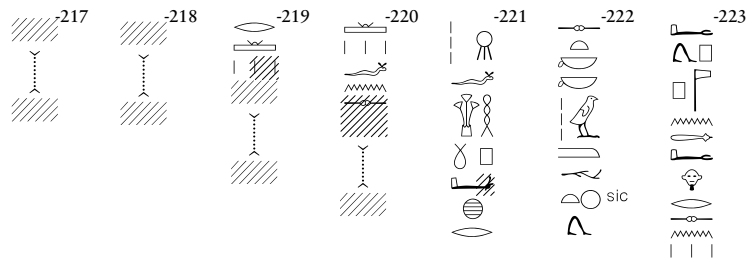

Hb. 37.14-18
(DOI 10.17171/2-8-108)

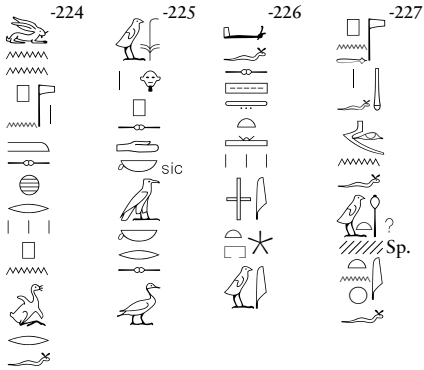

Hb. Sz. XXXII
(DOI 10.17171/2-8-25)

Hb. 37.27-35 (DOI 10.17171/2-8-108)

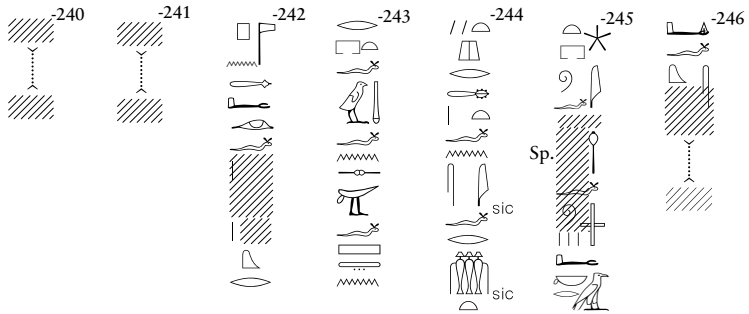

Hb. 37.25-26 (DOI 10.17171/2-8-108)

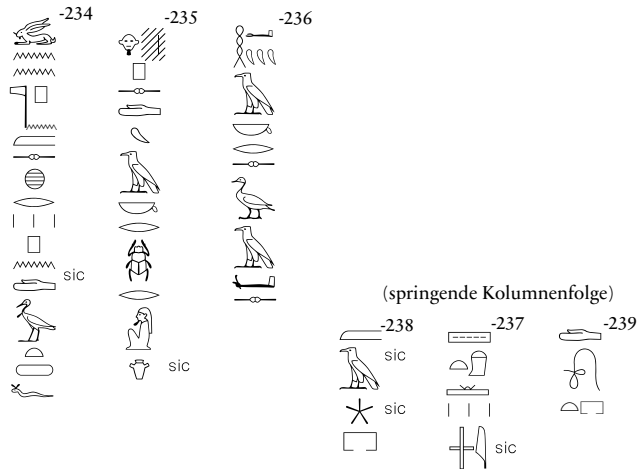

Hb. Sz. XXXII (DOI 10.17171/2-8-25)

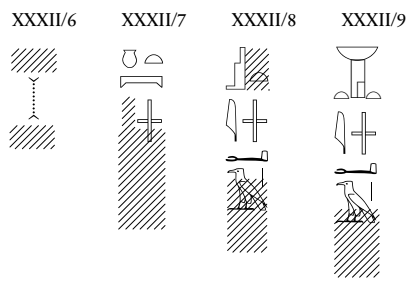

Hb. 37.19-24bis (DOI 10.17171/2-8-108)

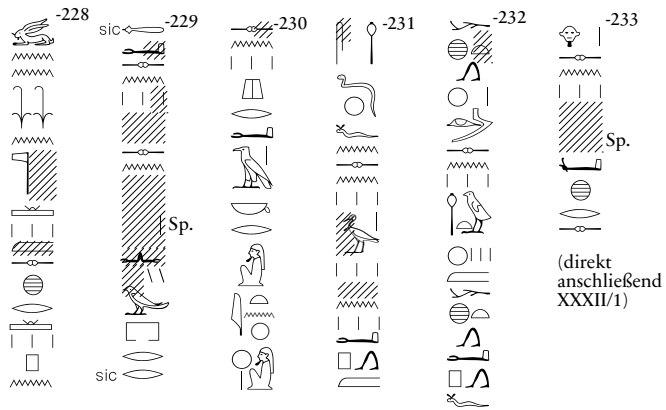

Hb. 37.55-77, Sz. XXXIIu
siehe Kol. 284ff., weiter unten.

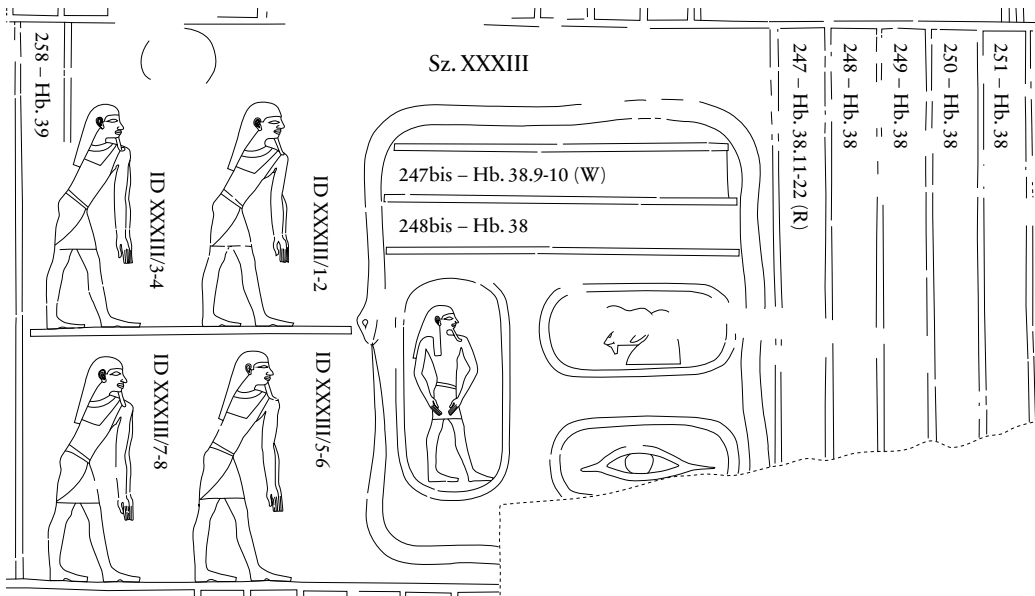

Hb. 38.11-22 (DOI 10.17171/2-8-109)



Hb. 38.9-10 (DOI 10.17171/2-8-26)



Hb. Sz. XXXIII
(DOI 10.17171/2-8-26)

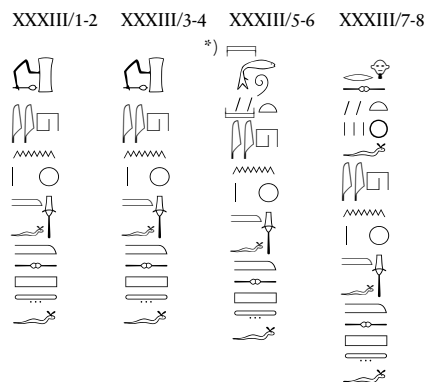

*) Photos Maystre

258 - Hb. 39	
257 - Hb. 39	
256 - Hb. 39	
255 - Hb. 39	
254 - Hb. 39	
253 - Hb. 39	
252 - Hb. 39, 13-30 + NN (R)	
261 - Hb. 39, 5-7 (W)	
260 - Hb. 39	
259 - Hb. 39.	
262 - Hb. 39, 8-12 (W)	
263 - Hb. 39	
264 - Hb. 39	
265 - Hb. 39	

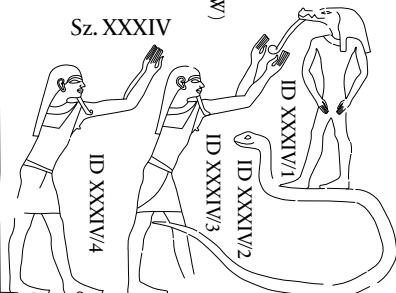

Hb. 39.13-30 (DOI 10.17171/2-8-110)



Hb. 39.5-7 (DOI 10.17171/2-8-27)

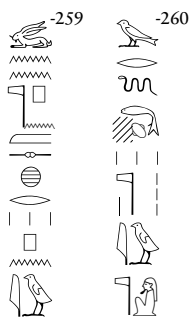

Hb. Sz. XXXIV (DOI 10.17171/2-8-27)

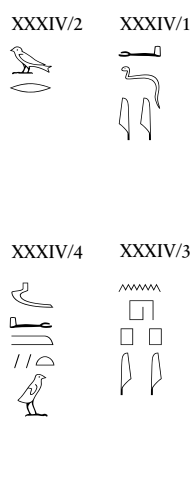

Hb. 39.8-12 (DOI 10.17171/2-8-27)

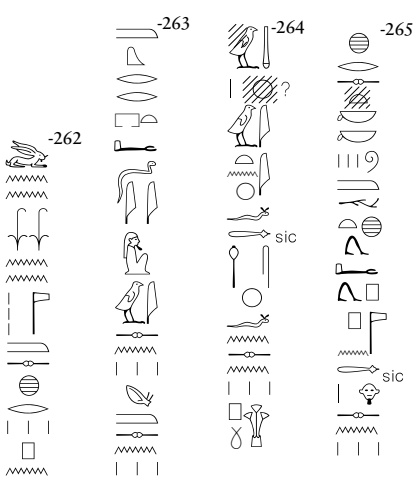

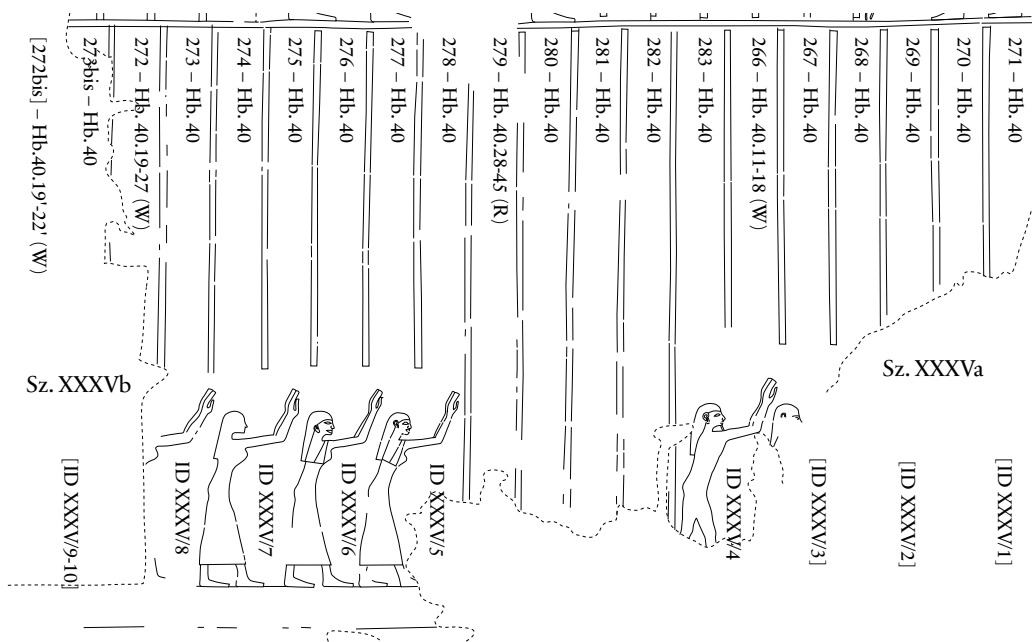

Hb. Sz. XXXV
(DOI 10.17171/2-8-28)

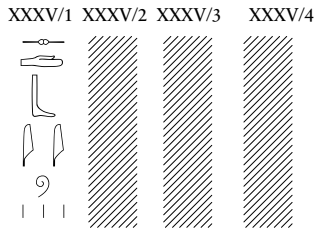

Hb. 40.11-18
(DOI 10.17171/2-8-111)

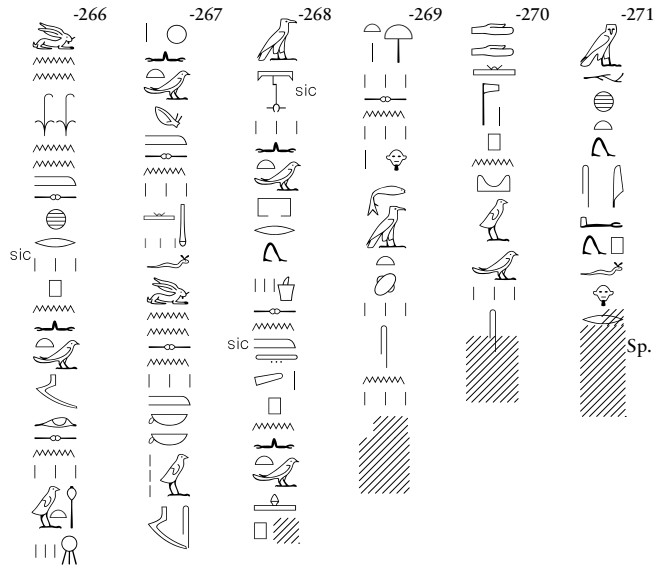

Hb. 40.28-45 (DOI 10.17171/2-8-111)

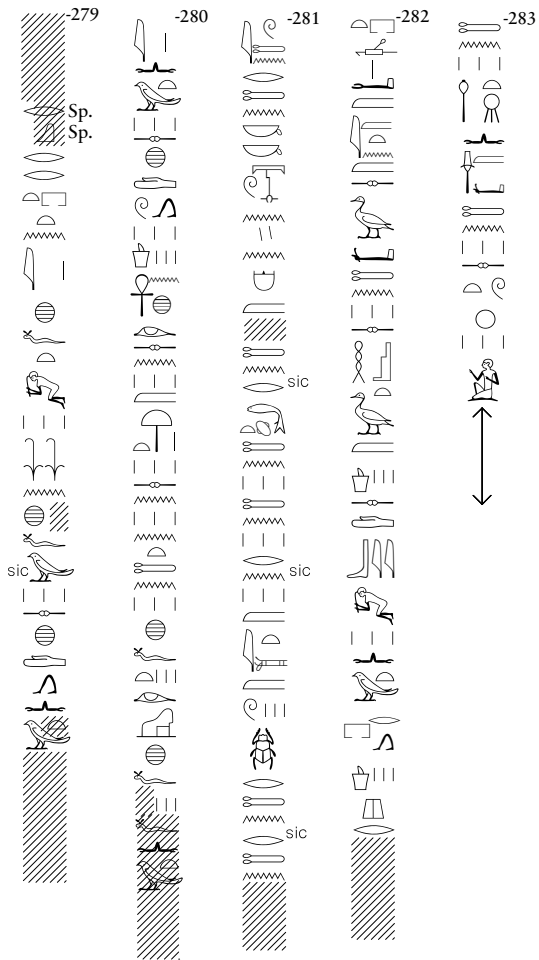

[287 – Hb. 37]

[286 – Hb. 37]

[285 – Hb. 37]

[284 – Hb. 37.64-77 (R.)]

[288] – Hb. 37.55.59 (W)

[289] – Hb. 37

[290] – Hb. 37

[291] – Hb. 37

[292] – Hb. 37

[293] – Hb. 37

[294] – Hb. 37

[295 – Hb. 37

[296 – Hb. 37

Sz. XXXIIu

[297bis – Hb. 37.60-63 (W)]

]

Hb. 37.55-77, Sz. XXXIIu (DOI 10.17171/2-8-292-7)

284-287 zerstört

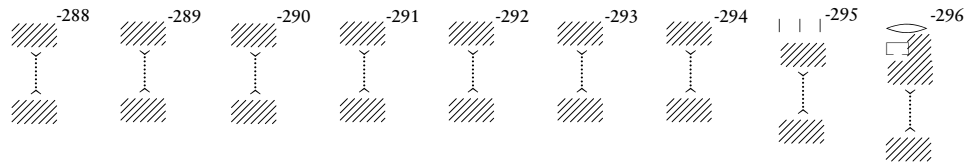

297bis zerstört

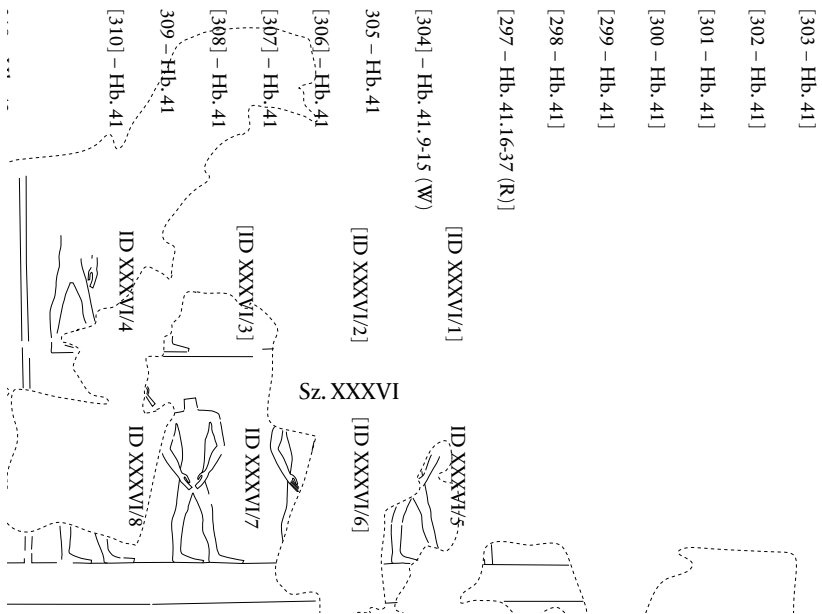

Hb. Sz. XXXVI (DOI 10.17171/2-8-29)

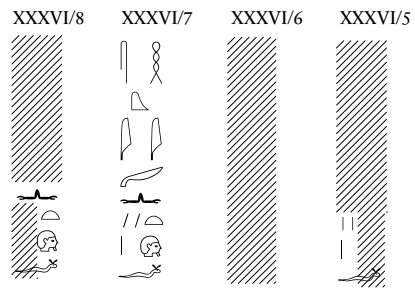
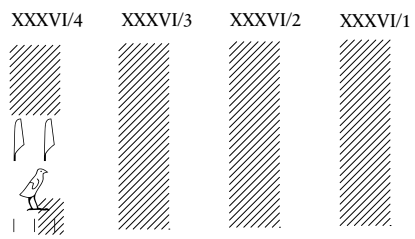

Hb. 41.16-37 (zerstört)

297-303 zerstört

Hb. 41.9-15 (DOI 10.17171/2-8-112)

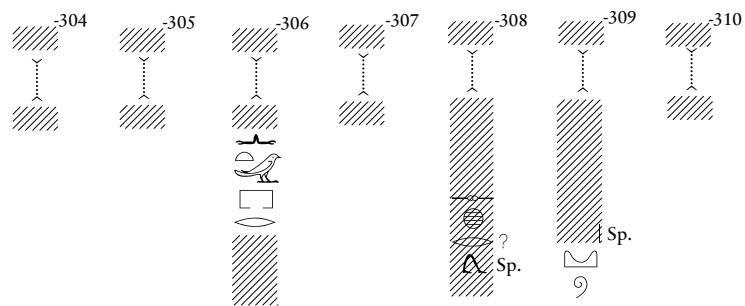

318 – Hb. 42	
317 – Hb. 42	
316 – Hb. 42	
315 – Hb. 42	
314 – Hb. 42	
313 – Hb. 42	
312 – Hb. 42	
311 – Hb. 42.16-31 (R)	
ID XXXVII/5	ID XXXVII/1
319 – Hb. 42.9-15	320 – Hb. 42 (W)
ID XXXVII/6	ID XXXVII/2
321 – Hb. 42	322 – Hb. 42
ID XXXVII/7	ID XXXVII/3
323 – Hb. 42	324 – Hb. 42
ID XXXVII/8	ID XXXVII/4
325 – Hb. 42	
326 – Hb. 42	Sz. XXXVII

Hb. 42.16-31 (DOI 10.17171/2-8-113)

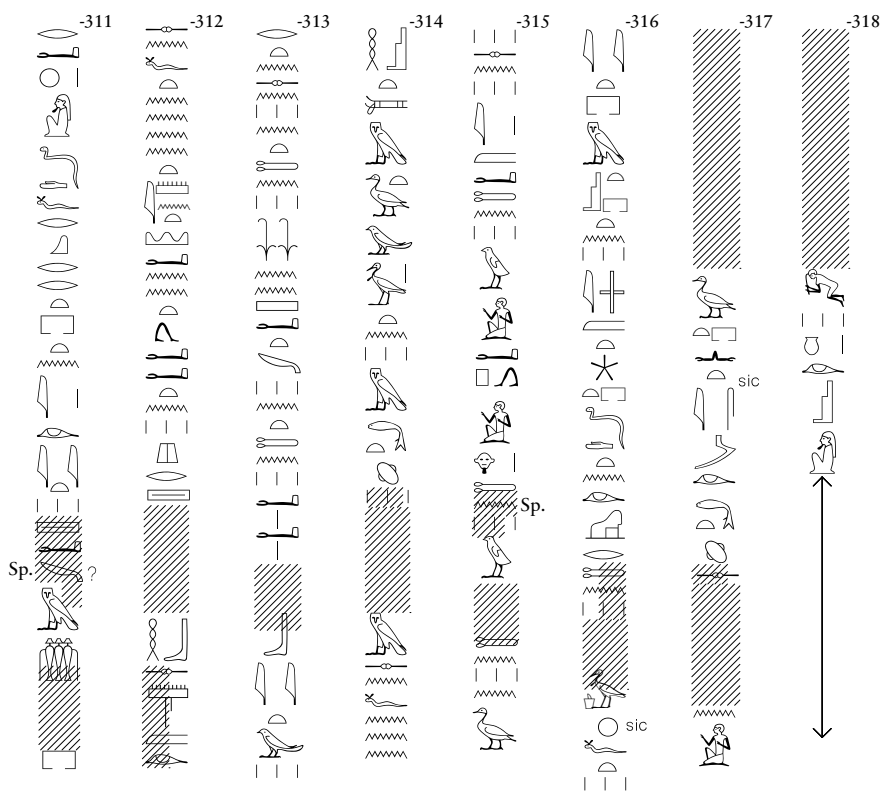

Hb. Sz. XXXVII (DOI 10.17171/2-8-30)

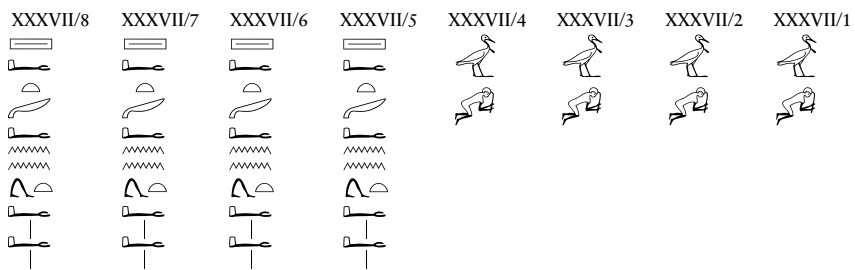

Hb. 42.9-15 (DOI 10.17171/2-8-113)

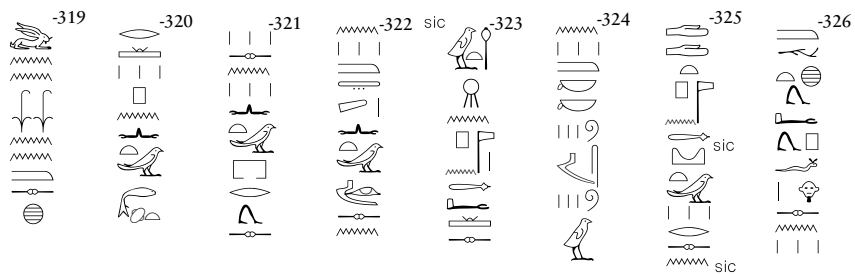

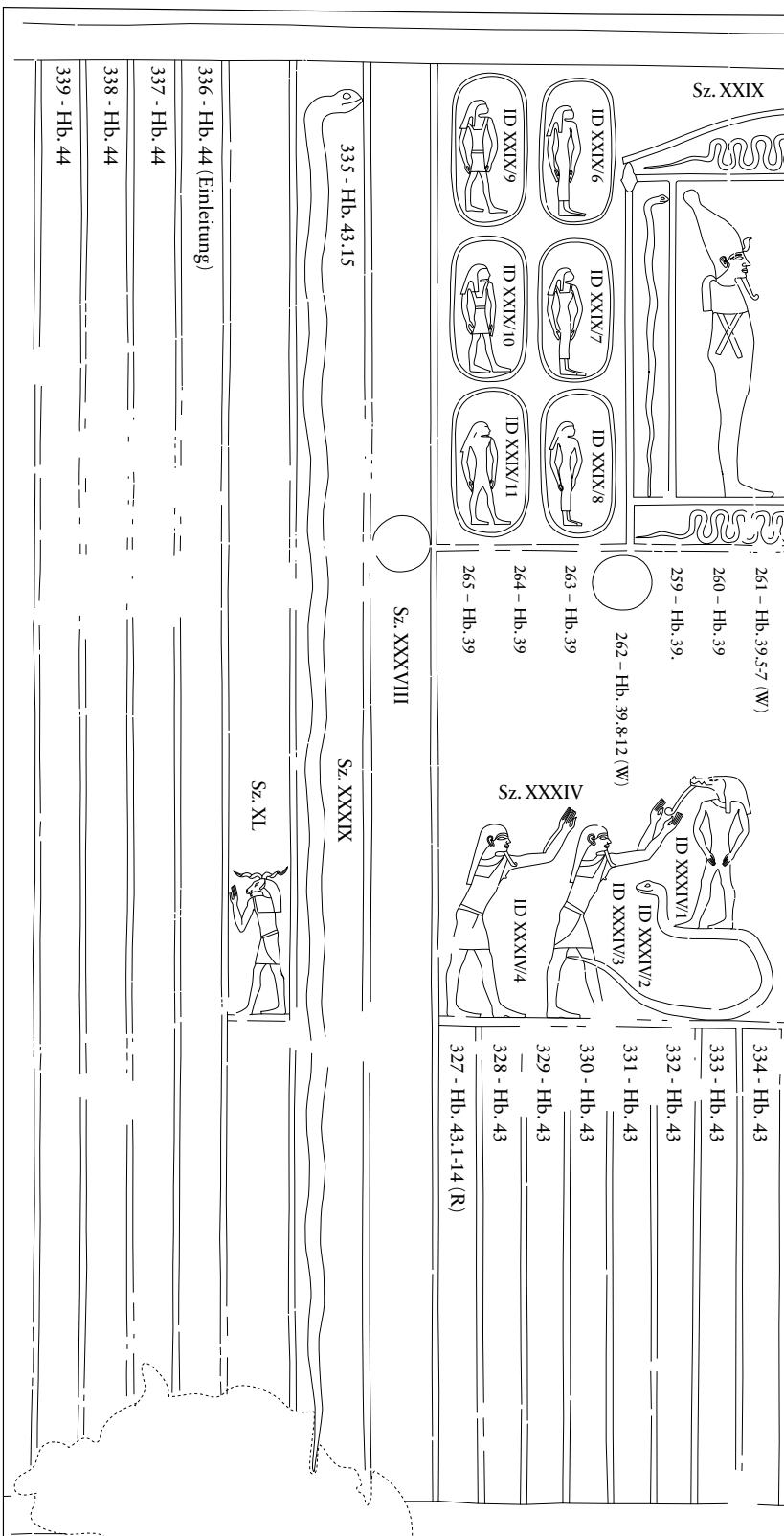

Hb. 43.1-14 (DOI 10.17171/2-8-114)



Hb. Sz. XXXIX, Hb. 43.15
(DOI 10.17171/2-8-32)

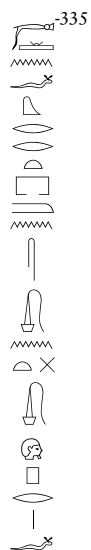

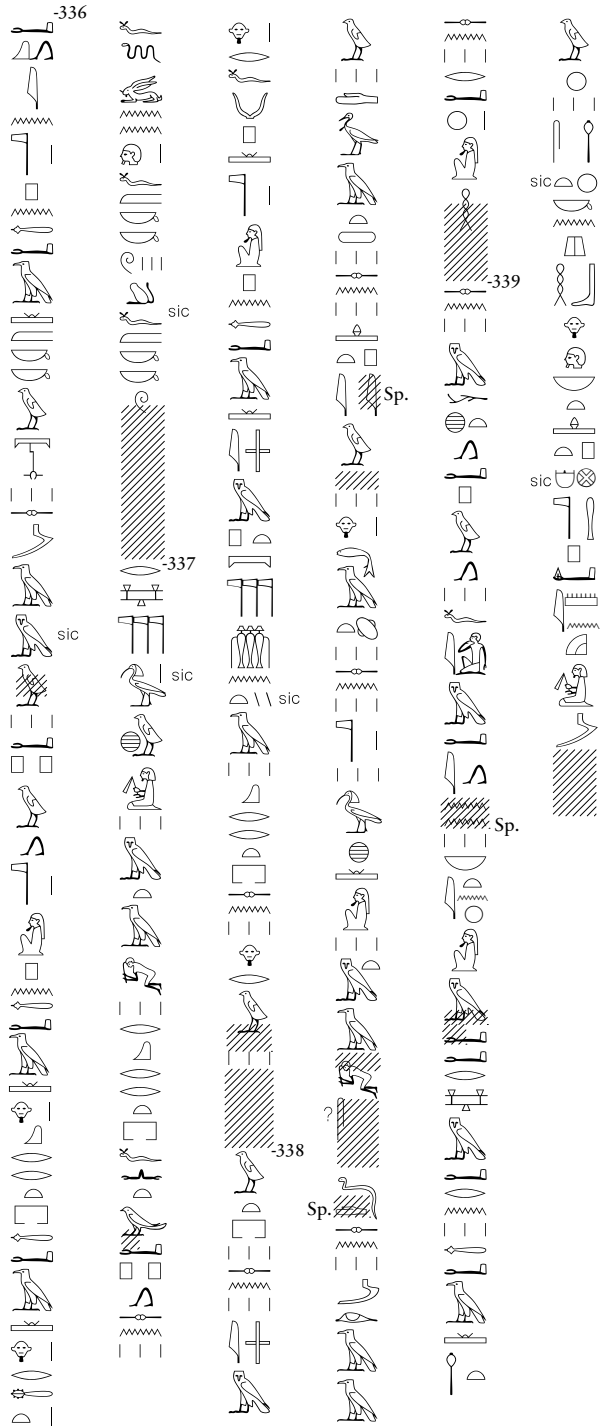

340 – Hb. 44 (Lit. 1.1)
341 – Hb. 44 (Lit. 1.2)
342 – Hb. 44 (Lit. 1.3)
343 – Hb. 44 (Lit. 1.4)
344 – Hb. 44 (Lit. 1.5)
345 – Hb. 44 (Lit. 1.6)
346 – Hb. 44 (Lit. 1.7)
347 – Hb. 44 (Lit. 1.8)
348 – Hb. 44 (Lit. 1.9)
349 – Hb. 44 (Lit. 1.10)
350 – Hb. 44 (Lit. 1.11)
351 – Hb. 44 (Lit. 1.12)
352 – Hb. 44 (Lit. 2.1)
353 – Hb. 44 (Lit. 2.2)
354 – Hb. 44 (Lit. 2.3)
355 – Hb. 44 (Lit. 2.4)
356 – Hb. 44 (Lit. 2.5)
357 – Hb. 44 (Lit. 2.6)
358 – Hb. 44 (Lit. 2.7)
359 – Hb. 44 (Lit. 2.8)
360 – Hb. 44 (Lit. 2.9)
361 – Hb. 44 (Lit. 2.10)
362 – Hb. 44 (Lit. 2.11)

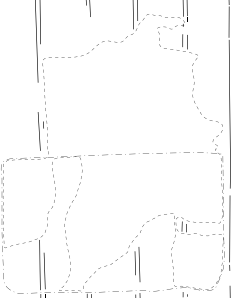

362 – Hb. 44 (Lit. 2.11)
363 – Hb. 44 (Lit. 2.12)
364 – Hb. 44 (Schluss)
365 – Hb. 44-45
366 – Hb. 45
367 – Hb. 45
368 – Hb. 45-46 (Einleitung)
369 – Hb. 46 (Einleitung)
370 – Hb. 46 (Einleitung)
371 – Hb. 46 (Einleitung)
372 – Hb. 46 (Einleitung)
373 – Hb. 46 (Einleitung)
374 – Hb. 46 (Einleitung-Lit. 3.1)
375 – Hb. 46 (Lit. 3.1-2.2)
376 – Hb. 46 (Lit. 3.2-Lit. 2.4)
377 – Hb. 46 (Lit. 3.4-2.5)
378 – Hb. 46 (Lit. 3.5-2.6)
379 – Hb. 46 (Lit. 3.6-2.8)
380 – Hb. 46 (Lit. 3.8-2.9)
381 – Hb. 46 (Lit. 3.9-2.10)
382 – Hb. 46 (Lit. 3.10-2.11)
383 – Hb. 46 (Lit. 3.11-2.12)
384 – Hb. 46 (Lit. 3.12)

Hb. 44.18-41 (DOI 10.17171/2-8-115)

sic ← →

sic ← →

← →

← →

sic ← →

← →

← →

← →

← →

-349
 -350
 -351
 -352
 -353
 -354
 -355
 -356
 -357

*) Bart vergessen.





Hb. 45
(DOI 10.17171/2-8-116)





358
359
360
361
362
363
364
365
366





The image shows a vertical column of hieroglyphic text, numbered 358 to 366. Each row contains several columns of hieroglyphs. The text is oriented vertically on the page. Some lines end with arrows pointing to the right. The word 'sic' is written below certain hieroglyphs. Row 366 is partially obscured by a horizontal line.





Hb. 46.24-47
(DOI 10.17171/2-8-117)

Hb. 46.48-67
(DOI 10.17171/2-8-117)





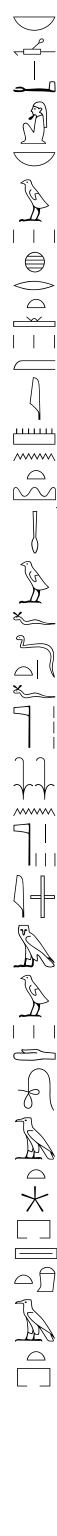











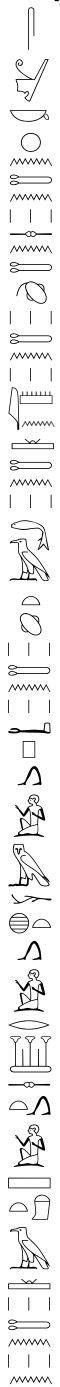

385 – Hb. 46 (Schluss)	
386 – Hb. 46 (Schluss)	
387 – Hb. 46 (Schluss)	
388 – Hb. 46 (Schluss)	
389 – Hb. 46 (Schluss)	

-389

-388

-387

-386

-385

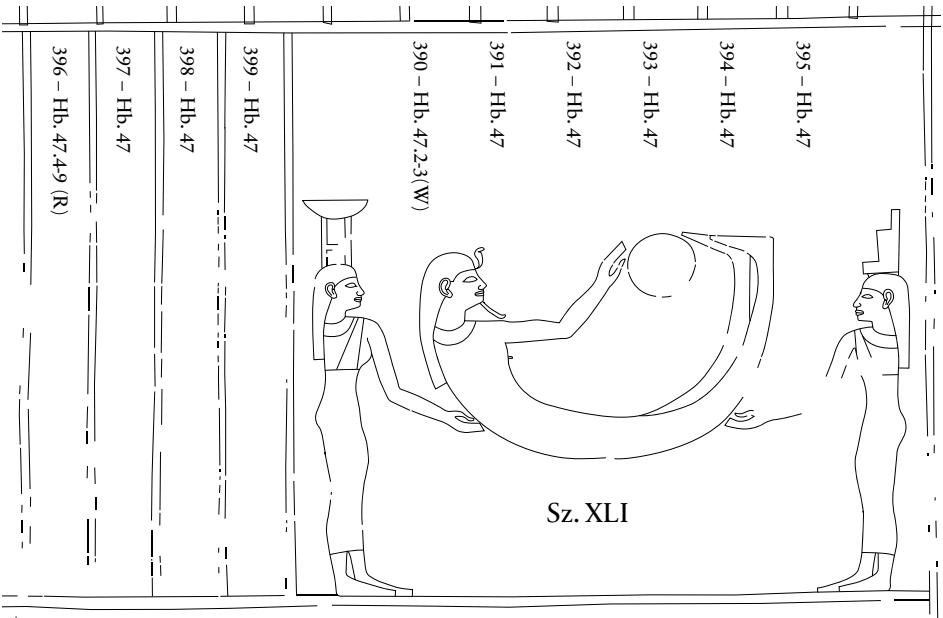
395 - Hb. 47

394 - Hb. 47

393 - Hb. 47

392 - Hb. 47

391 - Hb. 47

390 - Hb. 47.2.3 (W)

Sz. XLI

399 - Hb. 47

398 - Hb. 47

397 - Hb. 47

396 - Hb. 47.4.9 (R)

Hb. 47.2-3 (DOI 10.17171/2-8-34)

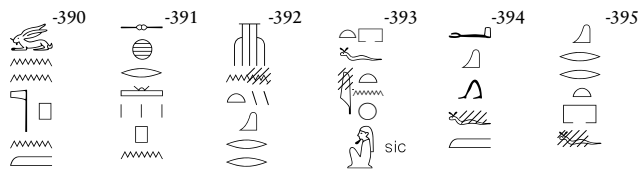

Hb. Sz. XLI (DOI 10.17171/2-8-34)

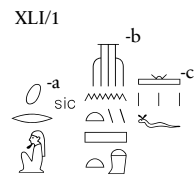

Hb. 47.4-9 (DOI 10.17171/2-8-118)

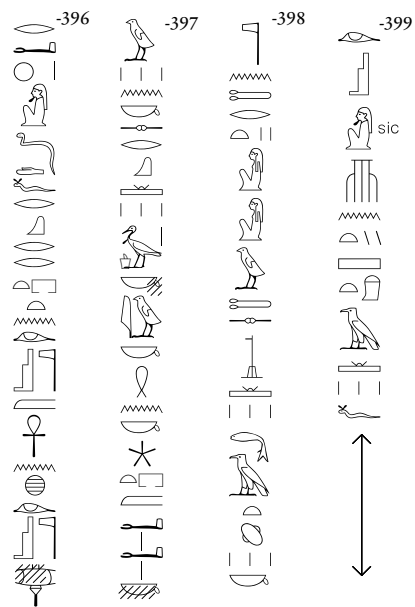

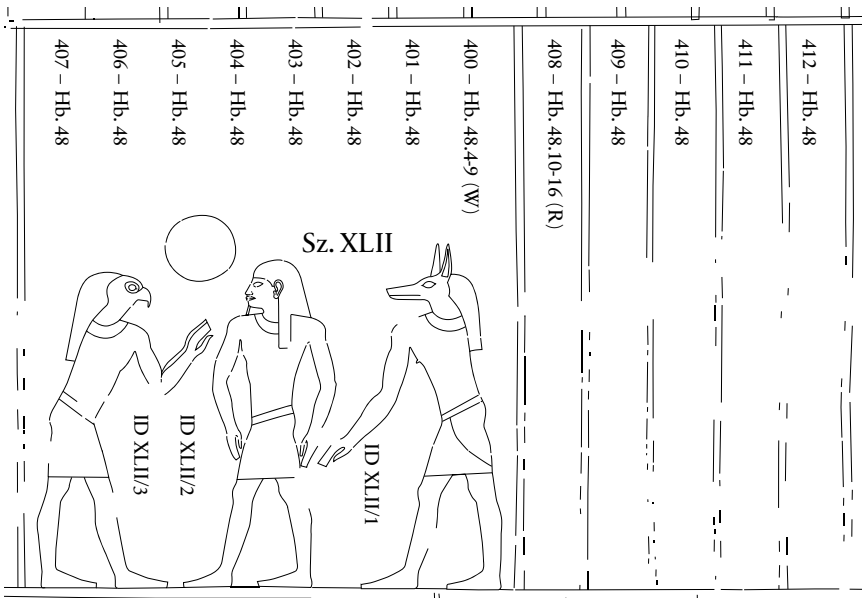

Hb. 48.10-16 (DOI 10.17171/2-8-119)

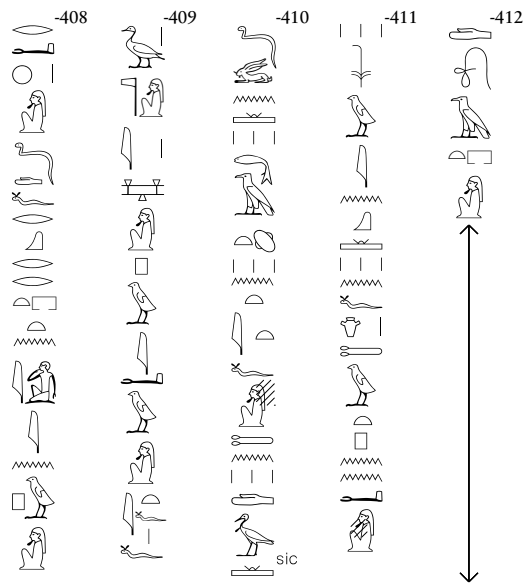

Hb. 48.4-9 (DOI 10.17171/2-8-35)

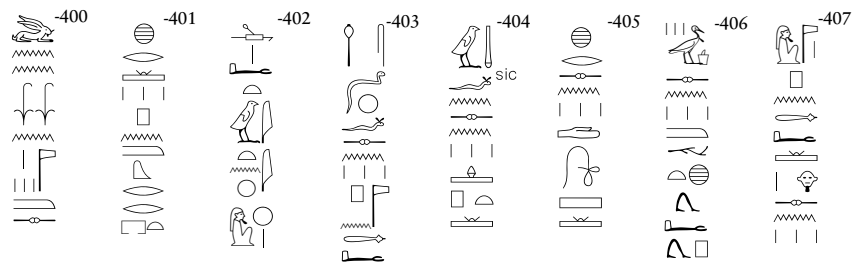

Hb. Sz. XLII (DOI 10.17171/2-8-35)

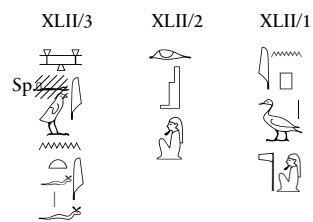

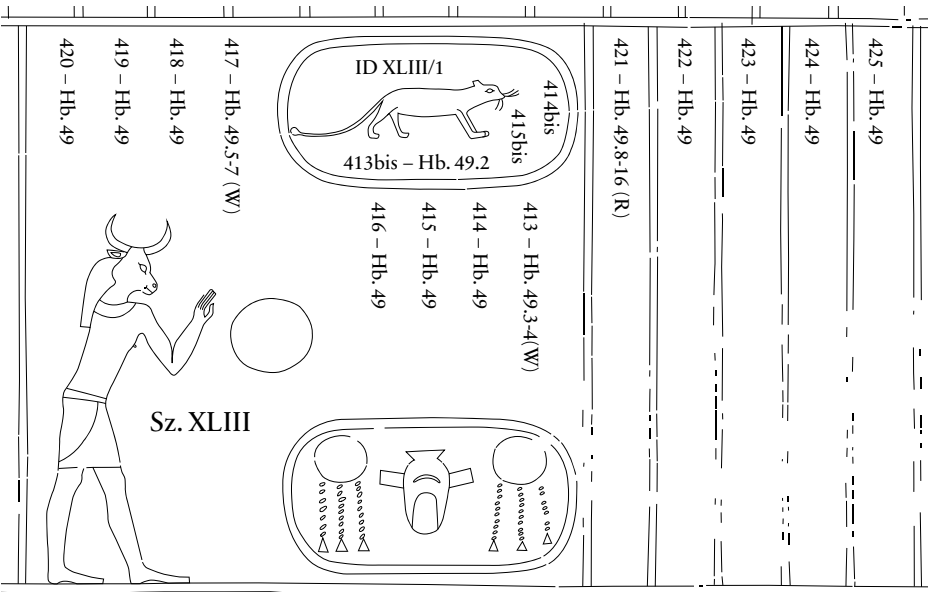

Hb. 49.8-16 (DOI 10.17171/2-8-120)



Hb. 49.5-7 (DOI 10.17171/2-8-36)

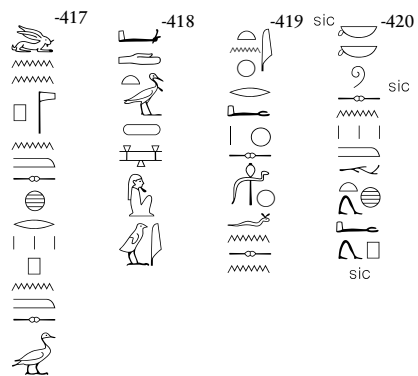

Hb. Sz. XLIII
(DOI 10.17171/2-8-36)

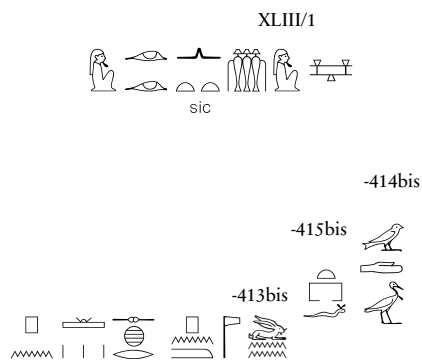

Hb. 49.3-4 (DOI 10.17171/2-8-36)

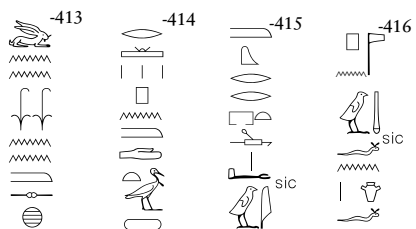

431 - Hb. 50
430 - Hb. 50
429 - Hb. 50
428 - Hb. 50
427 - Hb. 50
426 - Hb. 50.1-17 (R)

Hb. 50 (DOI 10.17171/2-8-121)

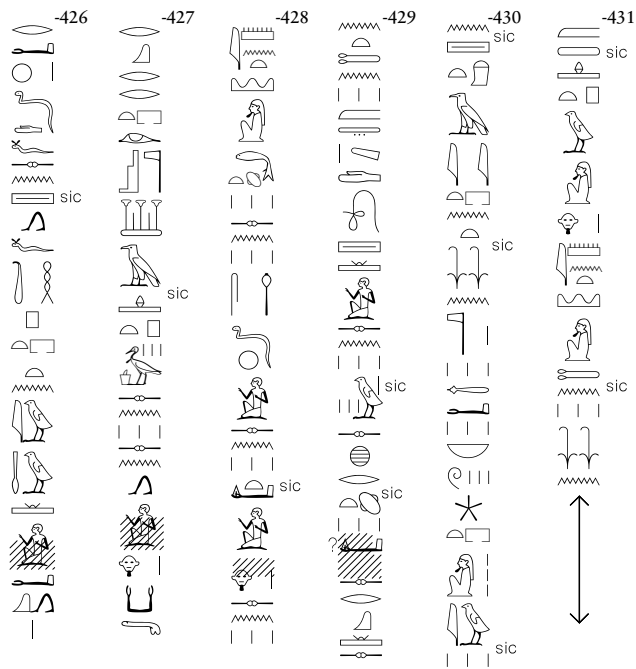

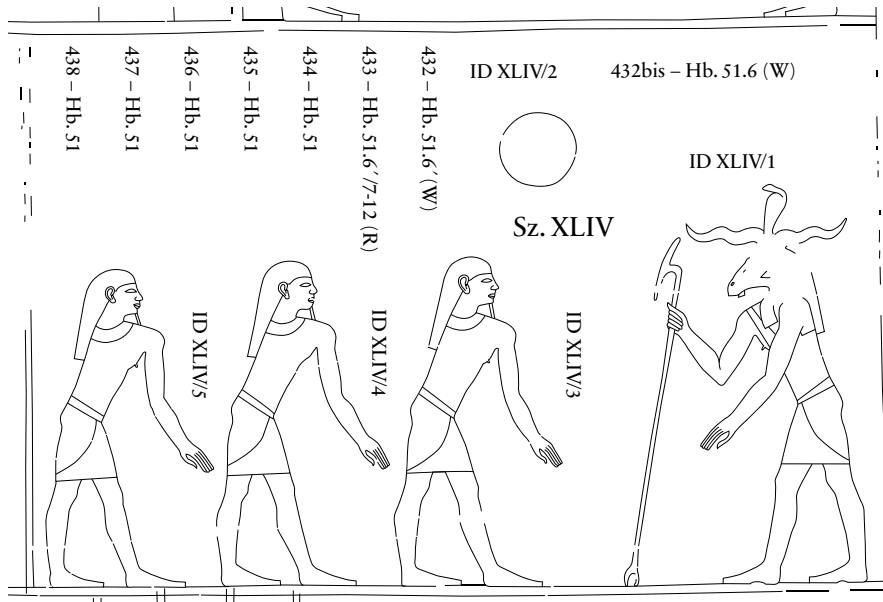

Hb. Sz. XLIV (DOI 10.17171/2-8-37)

XLIV/1

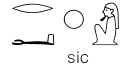

-432bis

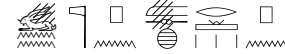

XLIV/3



XLIV/4



XLIV/5



XLIV/2



Hb. 51 (DOI 10.17171/2-8-122)

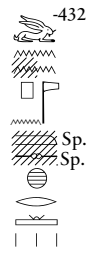

-432



-433

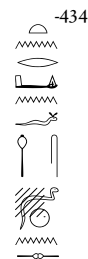

-434



-435

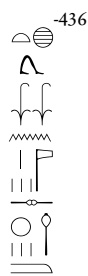

-436



-437

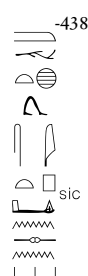

-438

sic

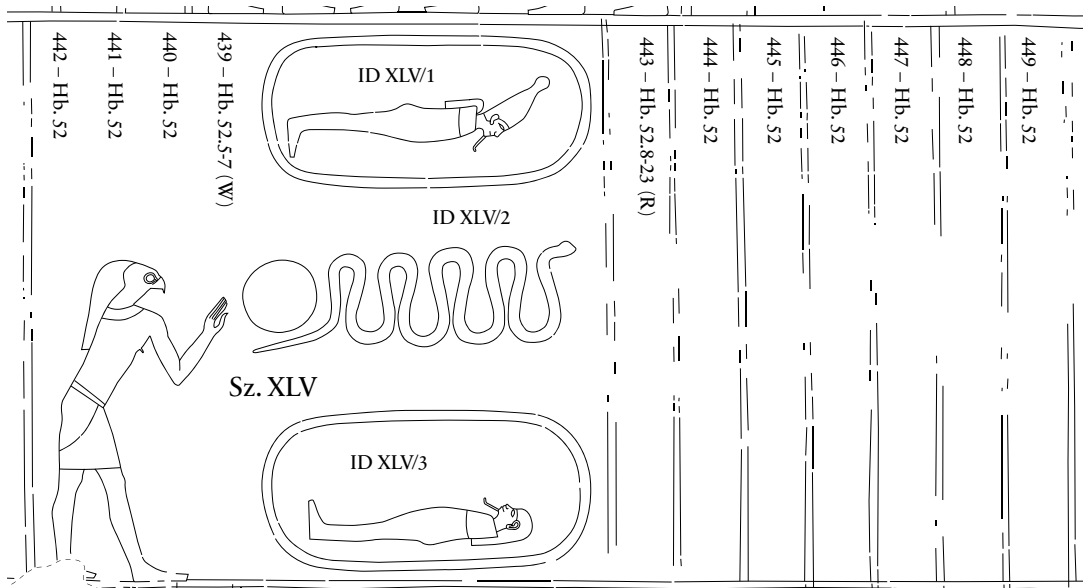

Hb. 52.8-23 (DOI 10.17171/2-8-123)

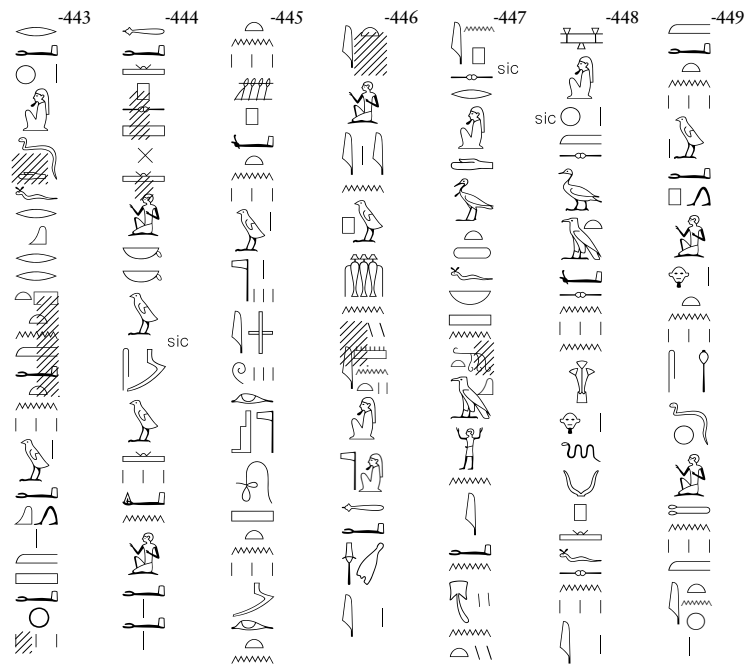

Hb. 52.5-7 (DOI 10.17171/2-8-38)

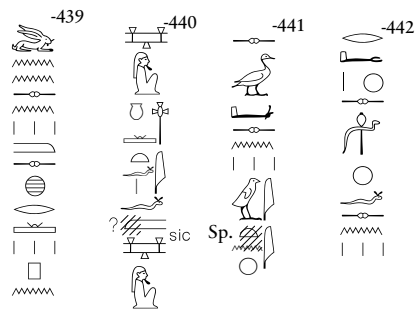

Hb. Sz. XLV
(DOI 10.17171/2-8-38)

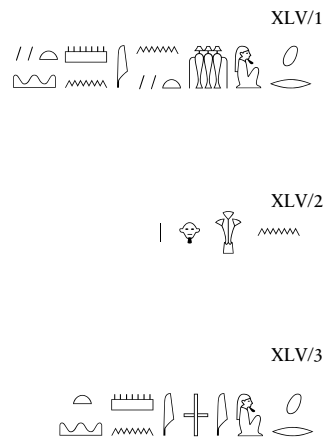

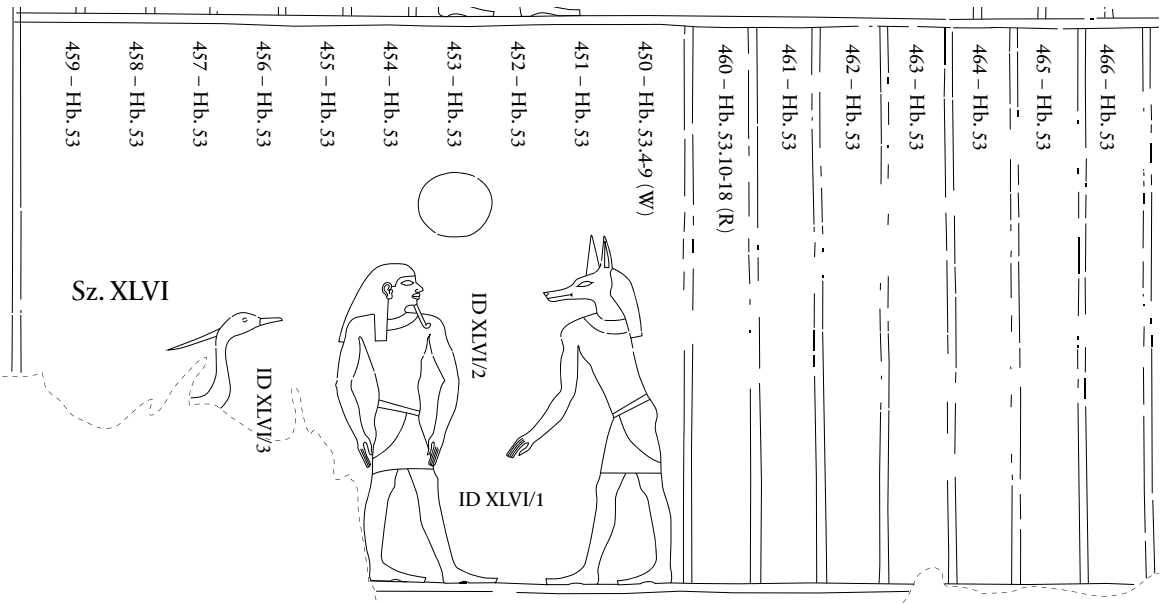

- 466 - Hb. 53
- 465 - Hb. 53
- 464 - Hb. 53
- 463 - Hb. 53
- 462 - Hb. 53
- 461 - Hb. 53
- 460 - Hb. 53.10-18 (R)
- 450 - Hb. 53.4-9 (W)
- 451 - Hb. 53
- 452 - Hb. 53
- 453 - Hb. 53
- 454 - Hb. 53
- 455 - Hb. 53
- 456 - Hb. 53
- 457 - Hb. 53
- 458 - Hb. 53
- 459 - Hb. 53

Sz. XLVI

ID XLVI/3

ID XLVI/2

ID XLVI/1

Hb. 53.10-18 (DOI 10.17171/2-8-124)

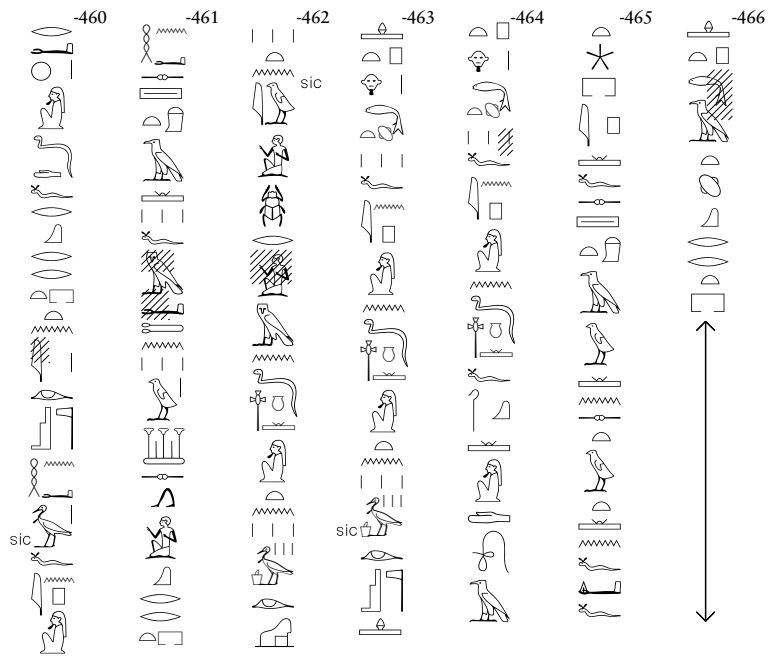

Hb. 53.4-9 (DOI 10.17171/2-8-39)

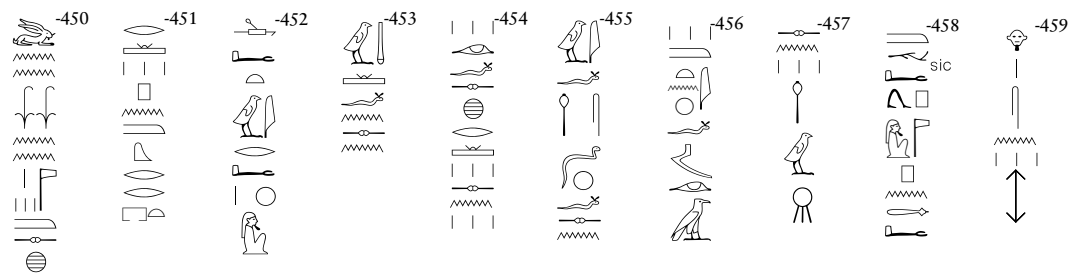

Hb. Sz. XLVI (DOI 10.17171/2-8-39)

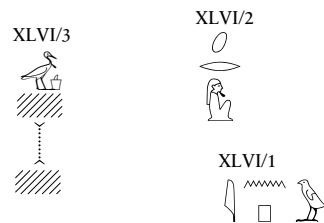

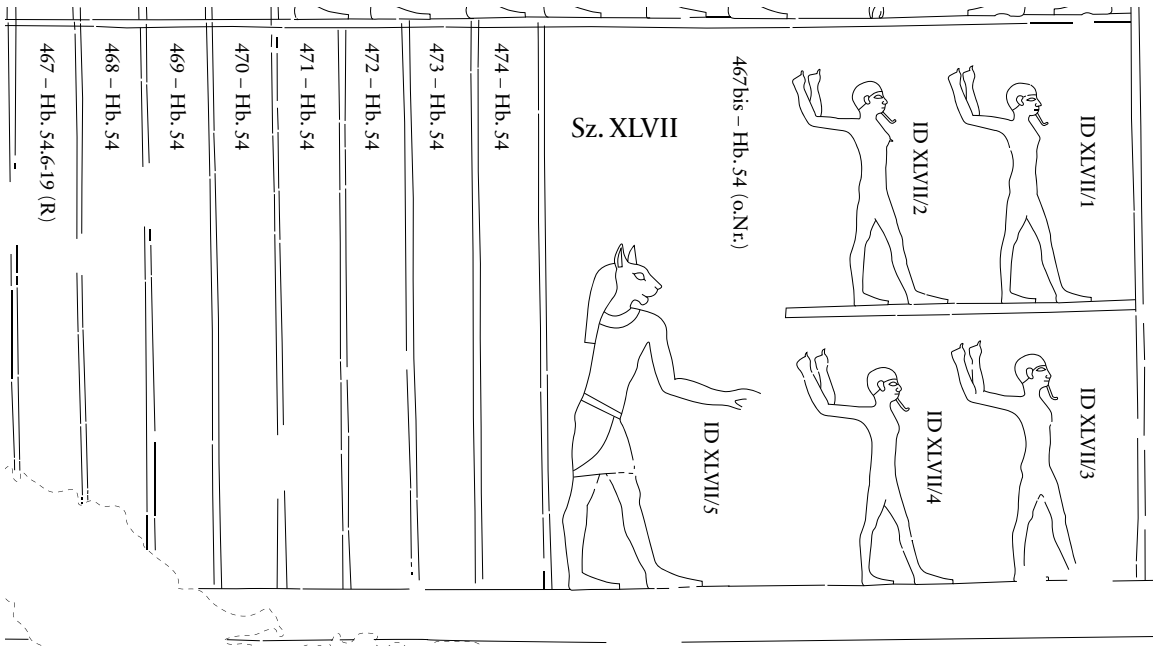

Hb. Sz. XLVII
(DOI 10.17171/2-8-40)

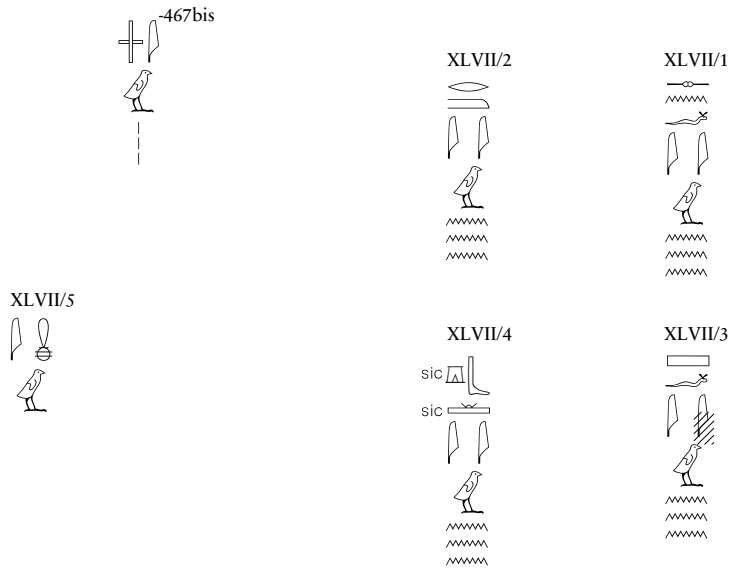

Hb. 54.6-19 (DOI 10.17171/2-8-125)

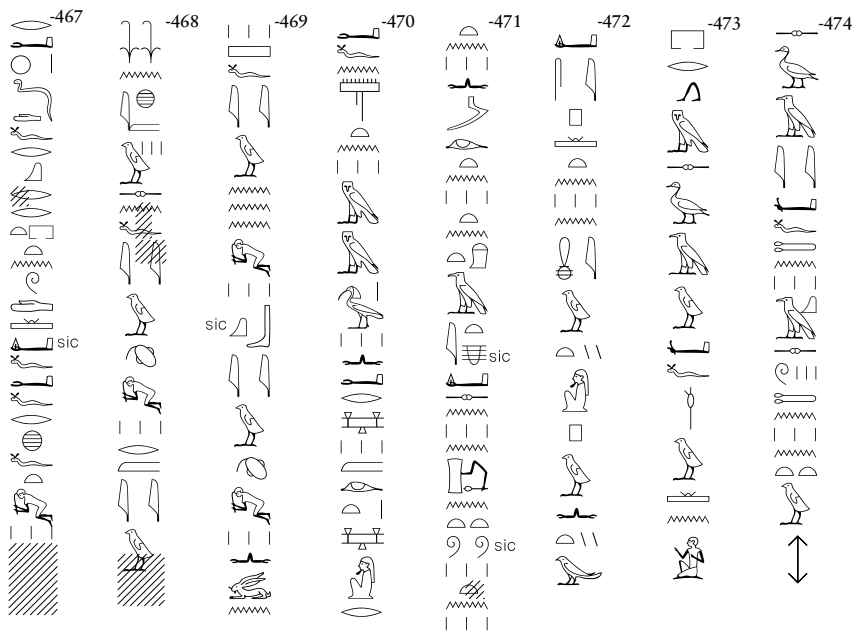

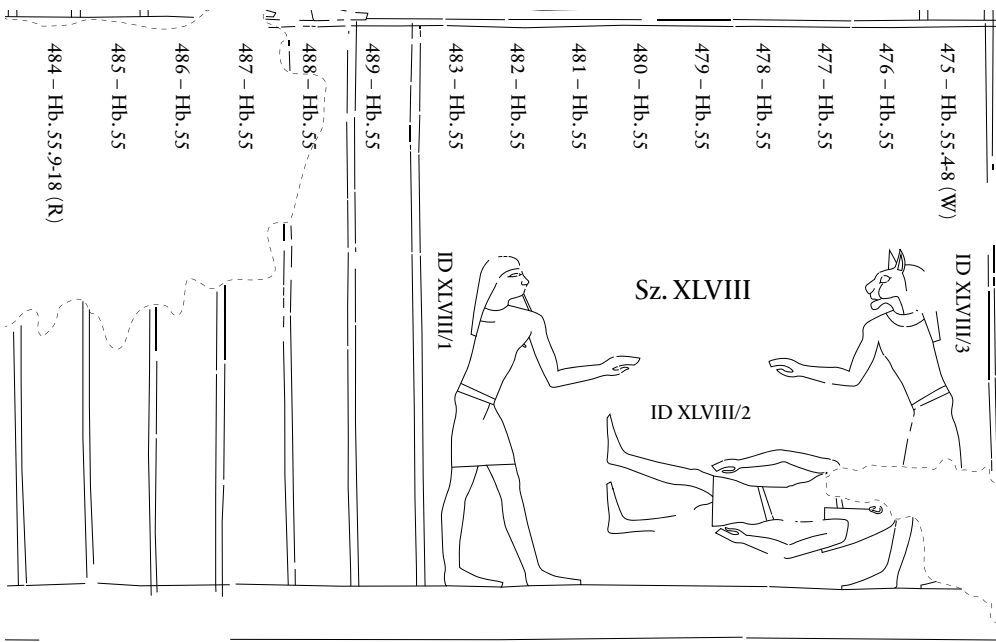

Hb. 55.4-8 (DOI 10.17171/2-8-41)

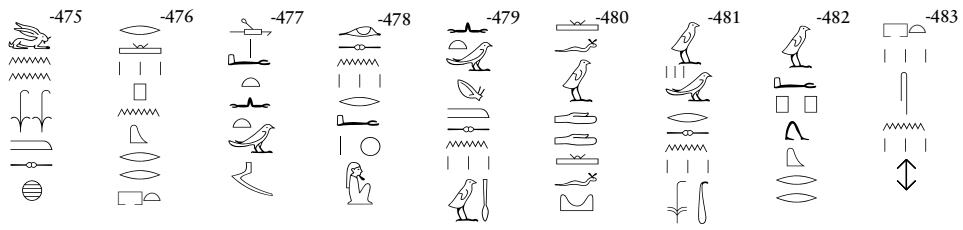

Hb. Sz. XLVIII (DOI 10.17171/2-8-41)

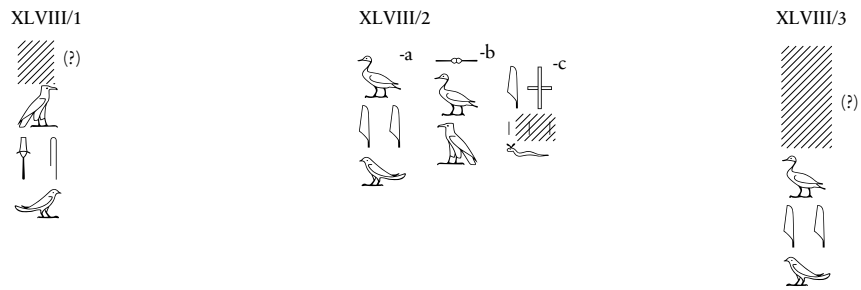

Hb. 55.9-18 (DOI 10.17171/2-8-126)

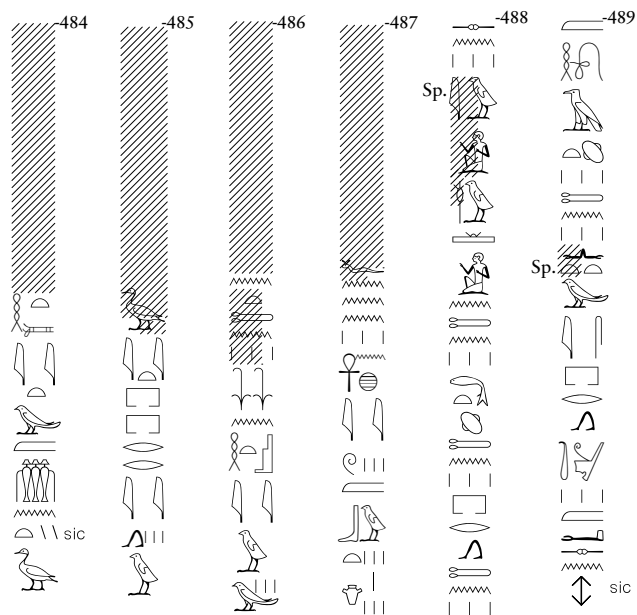

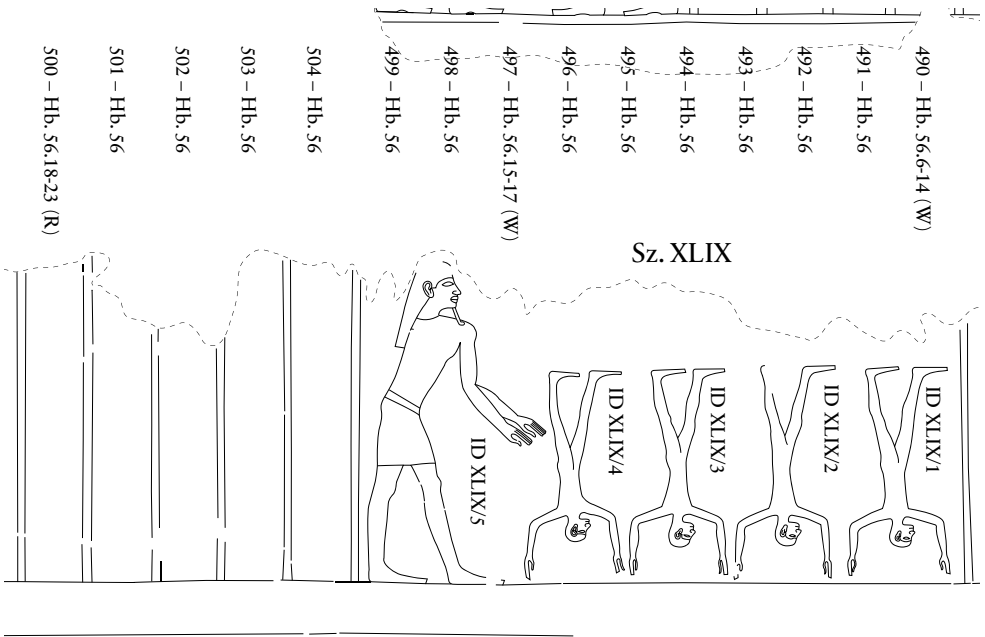

490 - Hb. 56:6-14 (W)

491 - Hb. 56

492 - Hb. 56

493 - Hb. 56

494 - Hb. 56

495 - Hb. 56

496 - Hb. 56

497 - Hb. 56:15-17 (W)

498 - Hb. 56

499 - Hb. 56

Sz. XLIX

ID XLIX/1

ID XLIX/2

ID XLIX/3

ID XLIX/4

ID XLIX/5

504 - Hb. 56

503 - Hb. 56

502 - Hb. 56

501 - Hb. 56

500 - Hb. 56:18-23 (R)

Hb. 56.6-17 (DOI 10.17171/2-8-42)

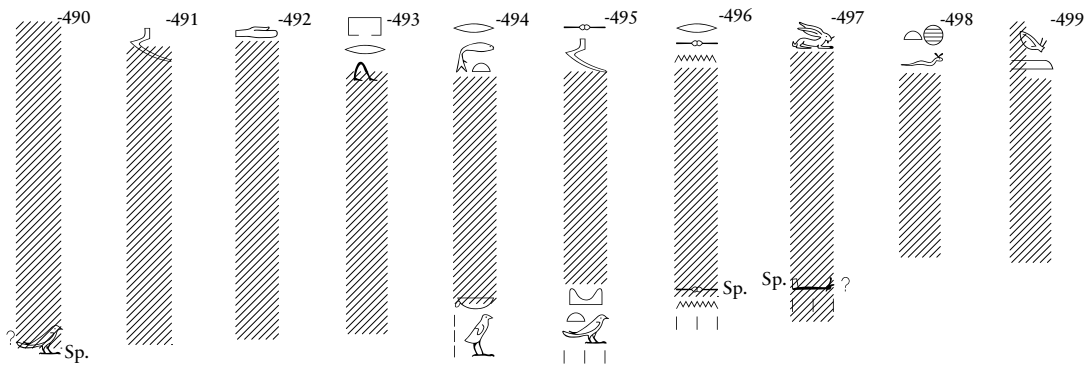

Hb. Sz. XLIX (DOI 10.17171/2-8-42)

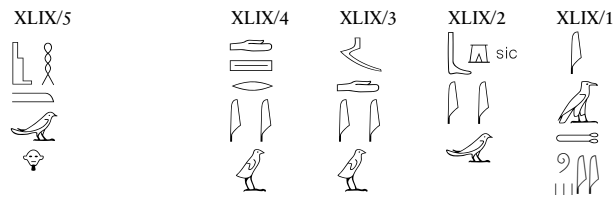

Hb. 56.18-23 (DOI 10.17171/2-8-127)

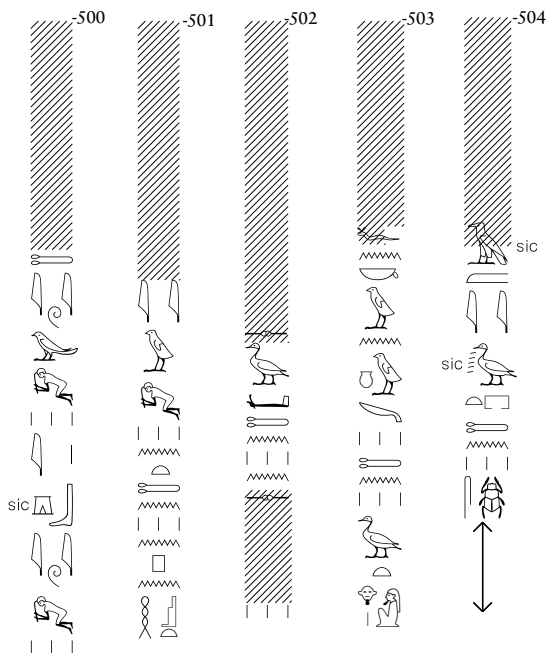

550 – Hb. 58 (Lit. 6.3)	[570 – Hb. 59 (Überleitung 5. Höhe)]
549 – Hb. 58 (Lit. 6.2)	[569 – Hb. 59 (Überleitung 5. Höhe)]
548 – Hb. 58 (Lit. 6.1)	568 – Hb. 59 (Überleitung 5. Höhe)
547 – Hb. 57 (Überleitung 5/6–58 (Einleitung))	567 – Hb. 59 (Anrufungen)
546 – Hb. 57 (Überleitung 5/6)	566 – Hb. 59 (Anrufungen)
545 – Hb. 57 (Überleitung 5/6)	565 – Hb. 59 (Anrufungen)
544 – Hb. 57 (Überleitung 5/6)	564 – Hb. 59 (Einleitung: Anrufungen)
543 – Hb. 57 (Überleitung 5/6)	563 – Hb. 58 (Überleitung 6/Anrufungen)
542 – Hb. 57 (Lit. 5.12)	562 – Hb. 58 (Überleitung 6/Anrufungen)
541 – Hb. 57 (Lit. 5.11)	561 – Hb. 58 (Überleitung 6/Anrufungen)
540 – Hb. 57 (Lit. 5.10)	560 – Hb. 58 (Überleitung 6/Anrufungen)
539 – Hb. 57 (Lit. 5.9)	559 – Hb. 58 (Lit. 6.12)
538 – Hb. 57 (Lit. 5.8)	558 – Hb. 58 (Lit. 6.11)
537 – Hb. 57 (Lit. 5.7)	557 – Hb. 58 (Lit. 6.10)
536 – Hb. 57 (Lit. 5.6)	556 – Hb. 58 (Lit. 6.9)
535 – Hb. 57 (Lit. 5.5)	555 – Hb. 58 (Lit. 6.8)
534 – Hb. 57 (Lit. 5.4)	554 – Hb. 58 (Lit. 6.7)
533 – Hb. 57 (Lit. 5.3)	553 – Hb. 58 (Lit. 6.6)
532 – Hb. 57 (Lit. 5.2)	552 – Hb. 58 (Lit. 6.5)
531 – Hb. 57 (Lit. 5.1)	551 – Hb. 58 (Lit. 6.4)
518 – Hb. 57 (Lit. 4.12)	[530 – Hb. 57 (Überleitung 4/5)]
517 – Hb. 57 (Lit. 4.11)	529 – Hb. 57 (Überleitung 4/5)
516 – Hb. 57 (Lit. 4.10)	528 – Hb. 57 (Überleitung 4/5)
515 – Hb. 57 (Lit. 4.9)	527 – Hb. 57 (Überleitung 4/5)
514 – Hb. 57 (Lit. 4.8)	526 – Hb. 57 (Überleitung 4/5)
513 – Hb. 57 (Lit. 4.7)	525 – Hb. 57 (Überleitung 4/5)
512 – Hb. 57 (Lit. 4.6)	524 – Hb. 57 (Überleitung 4/5)
511 – Hb. 57 (Lit. 4.5)	523 – Hb. 57 (Überleitung 4/5)
510 – Hb. 57 (Lit. 4.4)	522 – Hb. 57 (Überleitung 4/5)
509 – Hb. 57 (Lit. 4.3)	521 – Hb. 57 (Überleitung 4/5)
508 – Hb. 57 (Lit. 4.2)	520 – Hb. 57 (Überleitung 4/5)
507 – Hb. 57 (Lit. 4.1)	519 – Hb. 57 (Überleitung 4/5)
506 – Hb. 57 (Einleitung)	
505 – Hb. 57 (Einleitung)	

572 - Hb. 59
571 - Hb. 59.37(?) 46

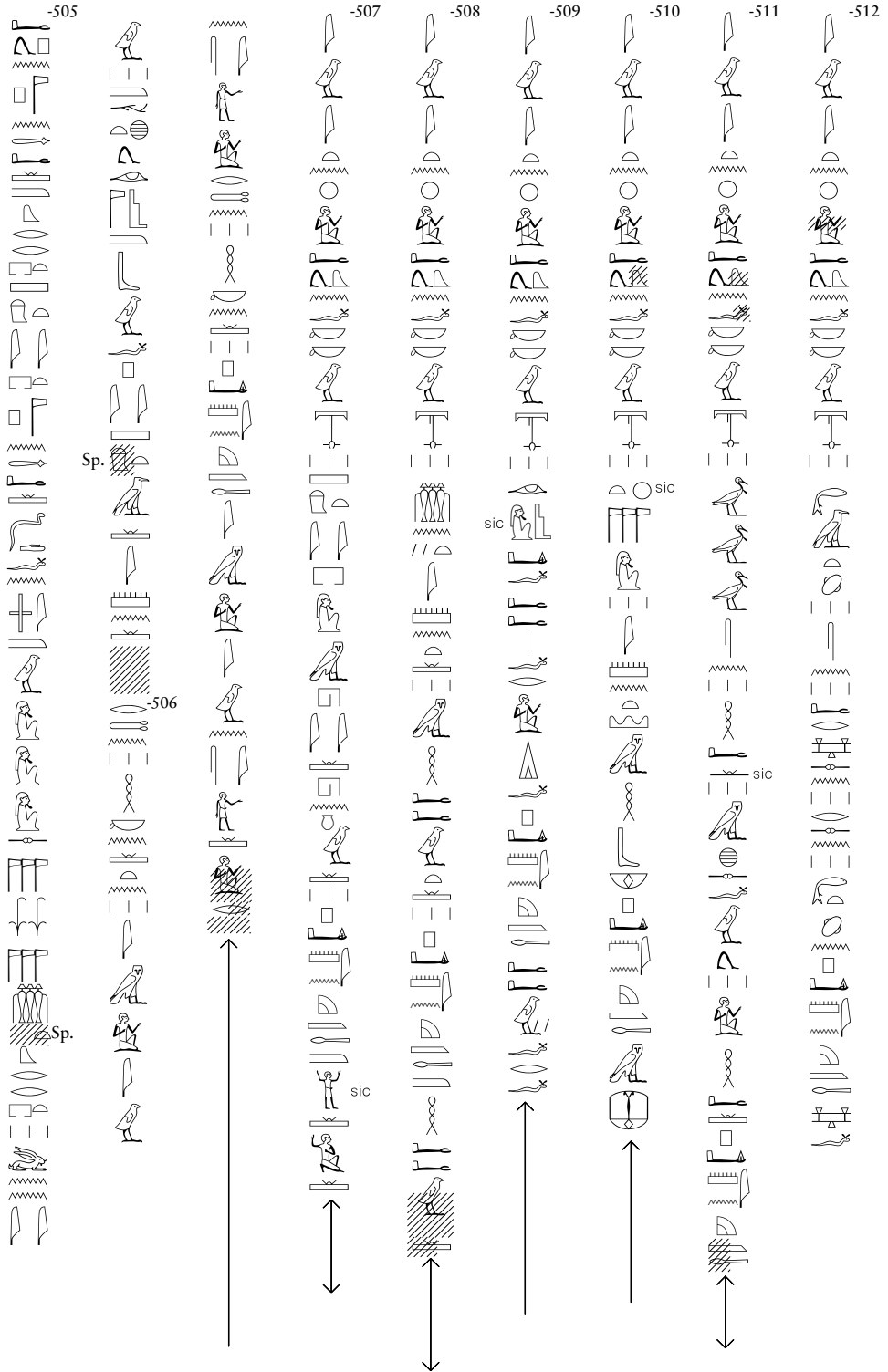

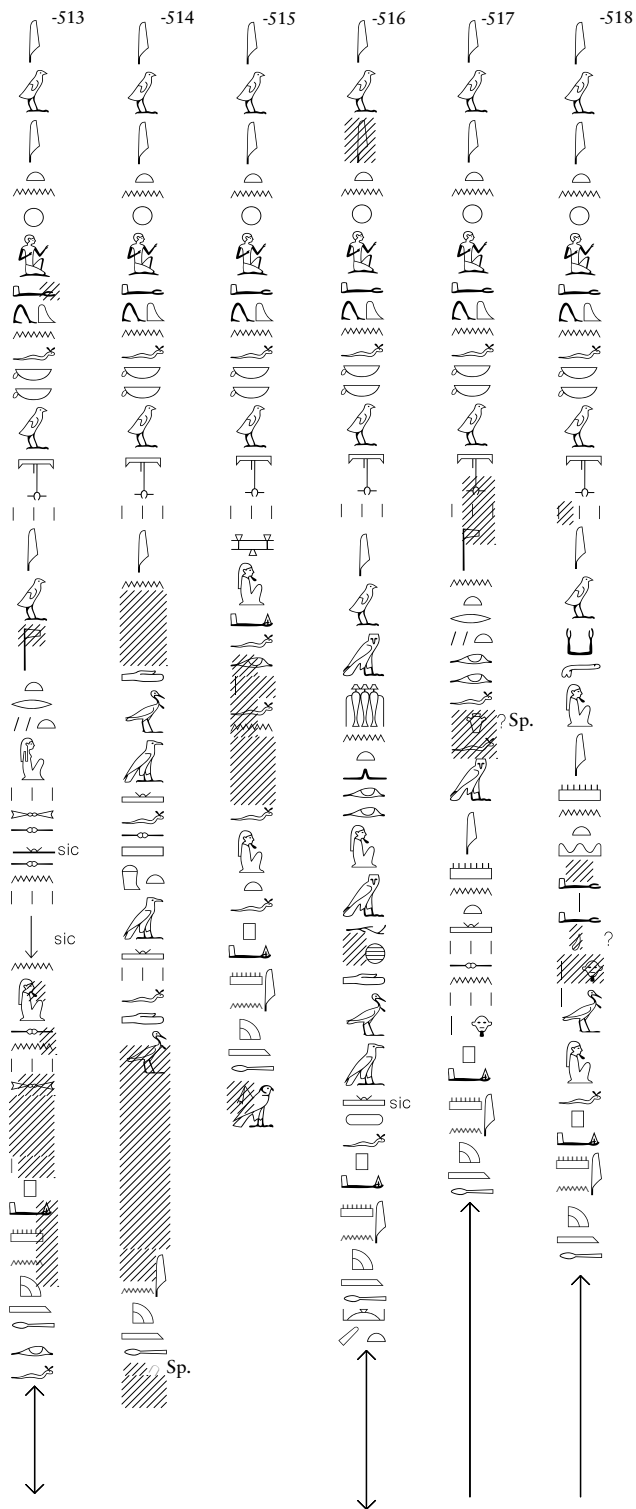

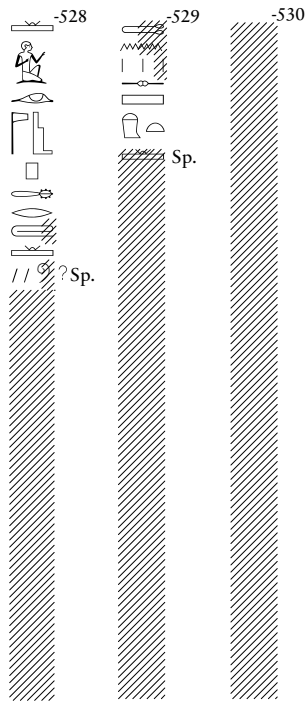
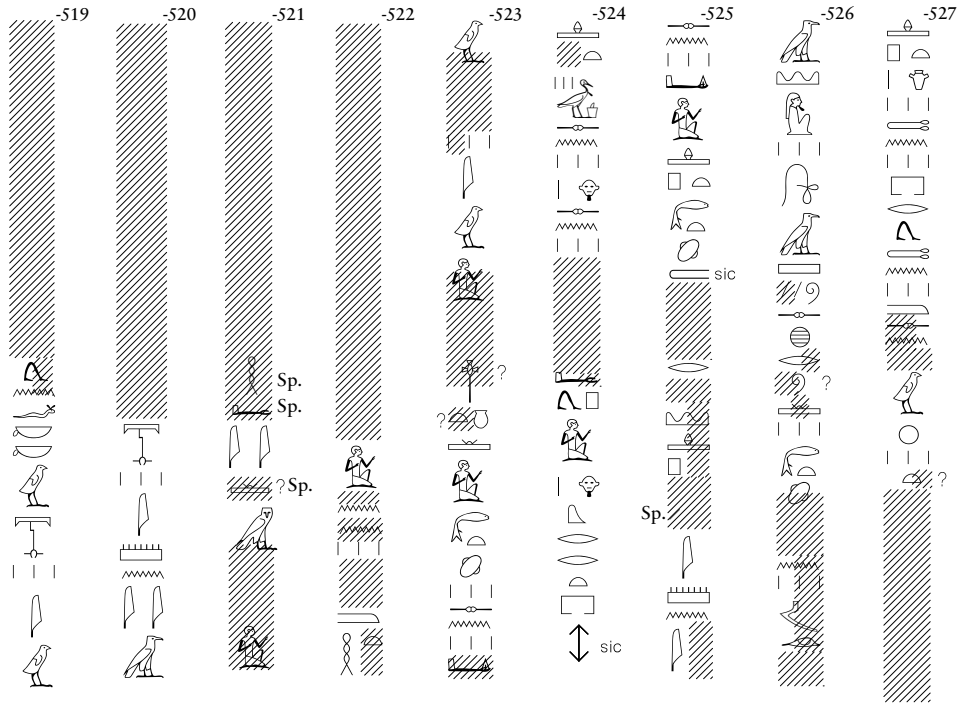

Hb. 57.53-80 (DOI 10.17171/2-8-128)

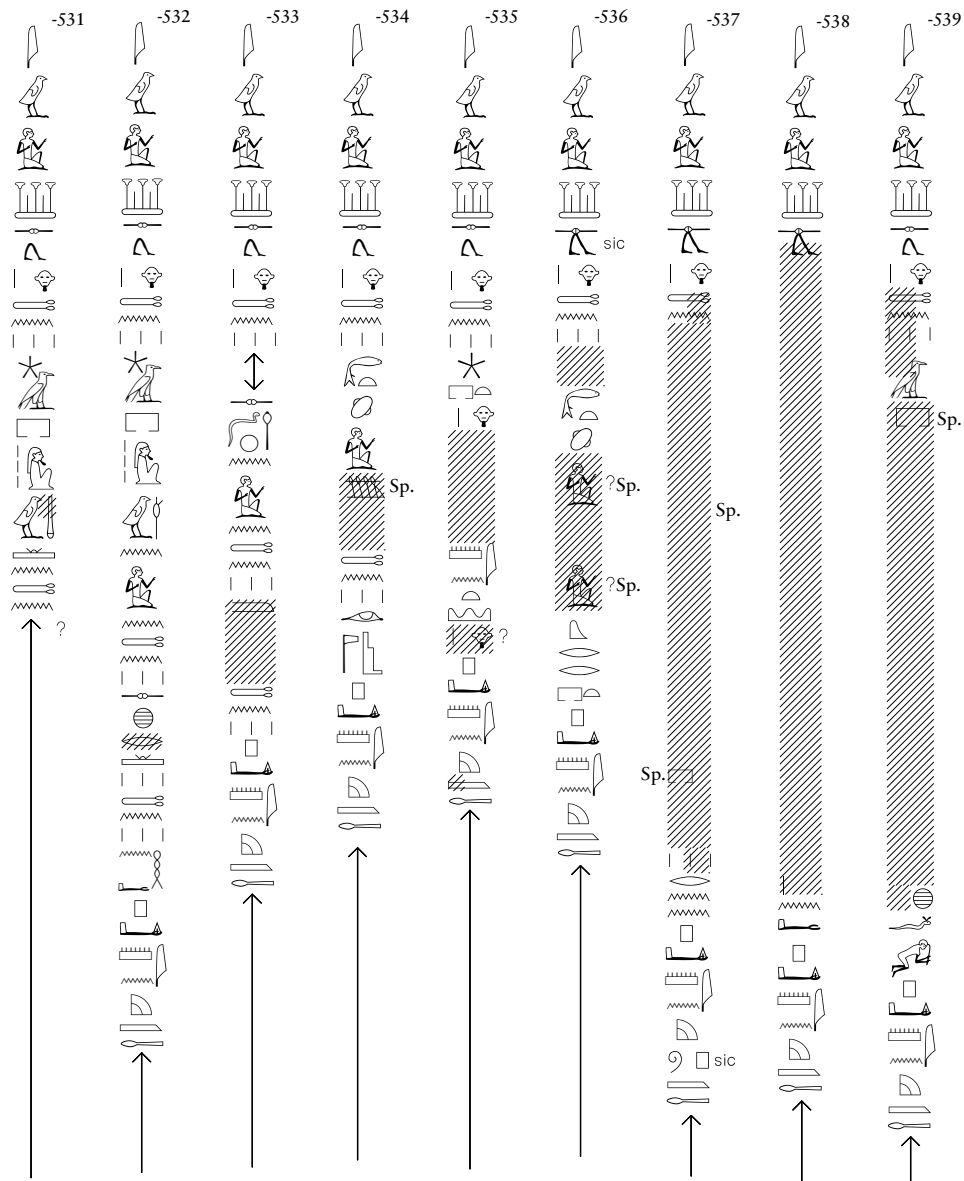

Hb. 57.81-88
(DOI 10.17171/2-8-128)

Hb. 58
(DOI 10.17171/2-8-129)

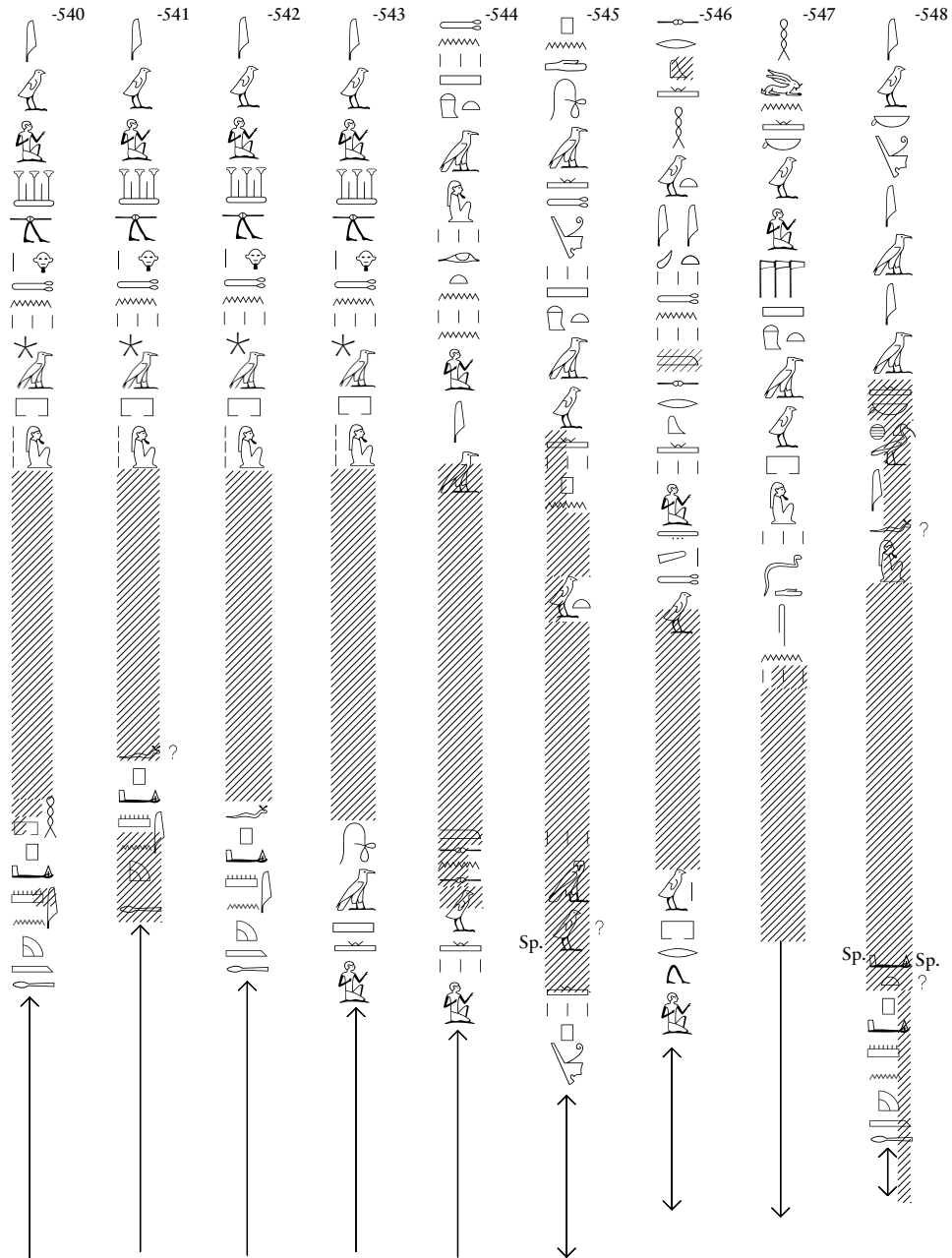

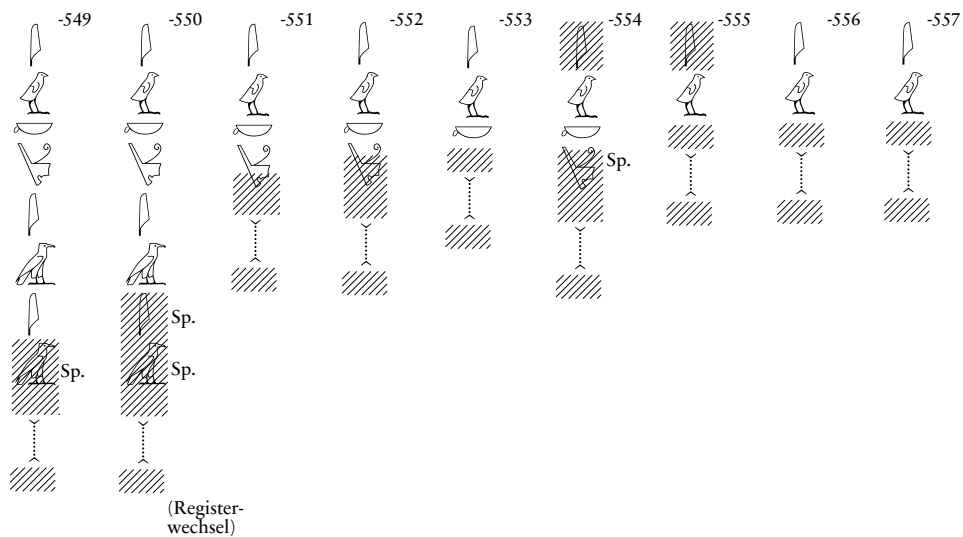

Hb. 59 (DOI 10.17171/2-8-130)

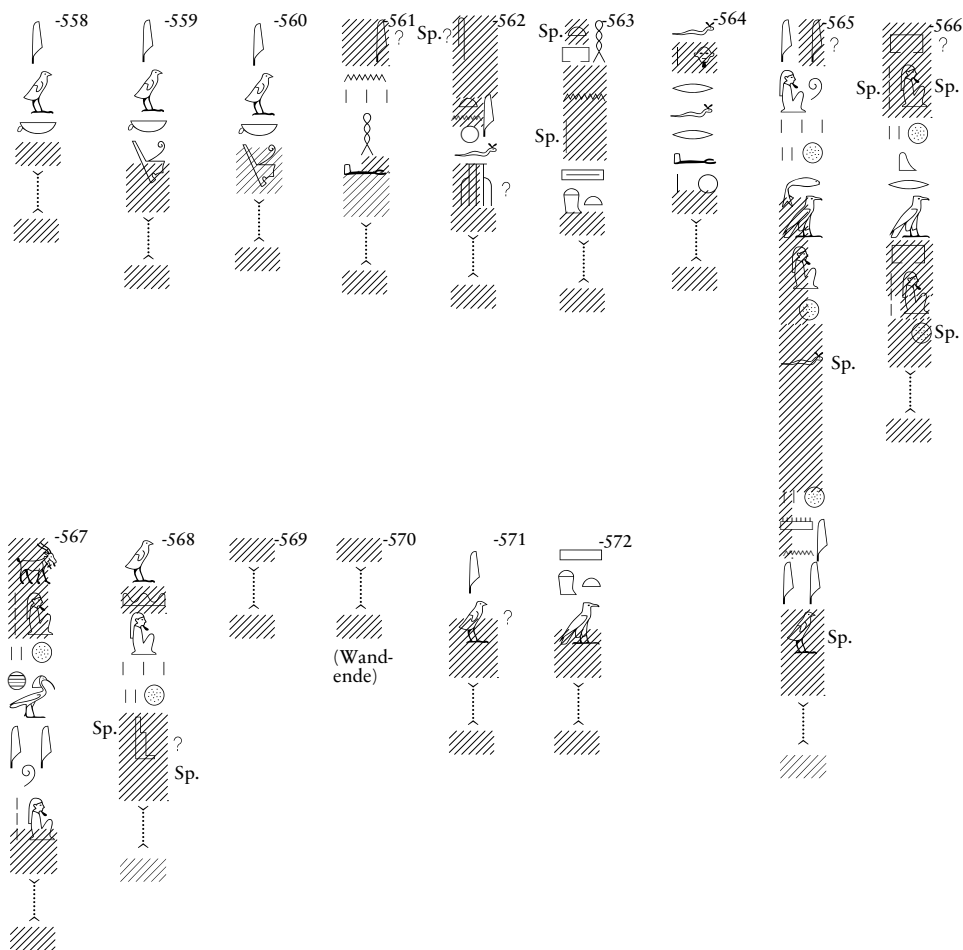

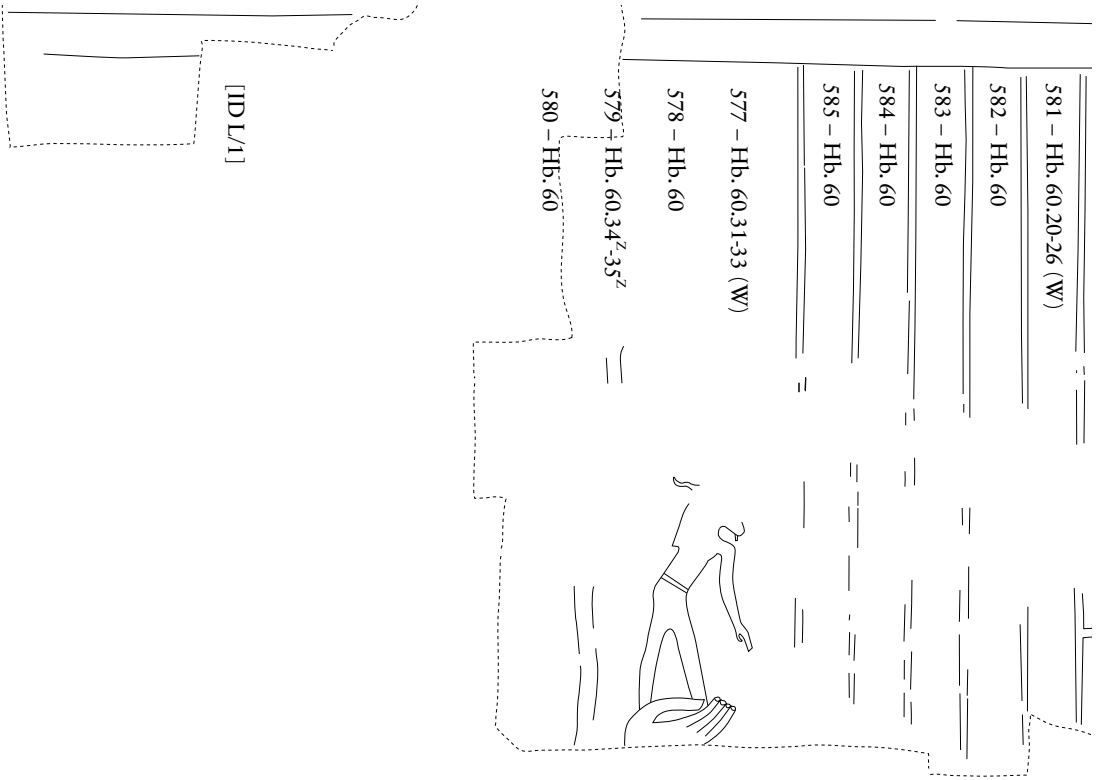

Sz. L

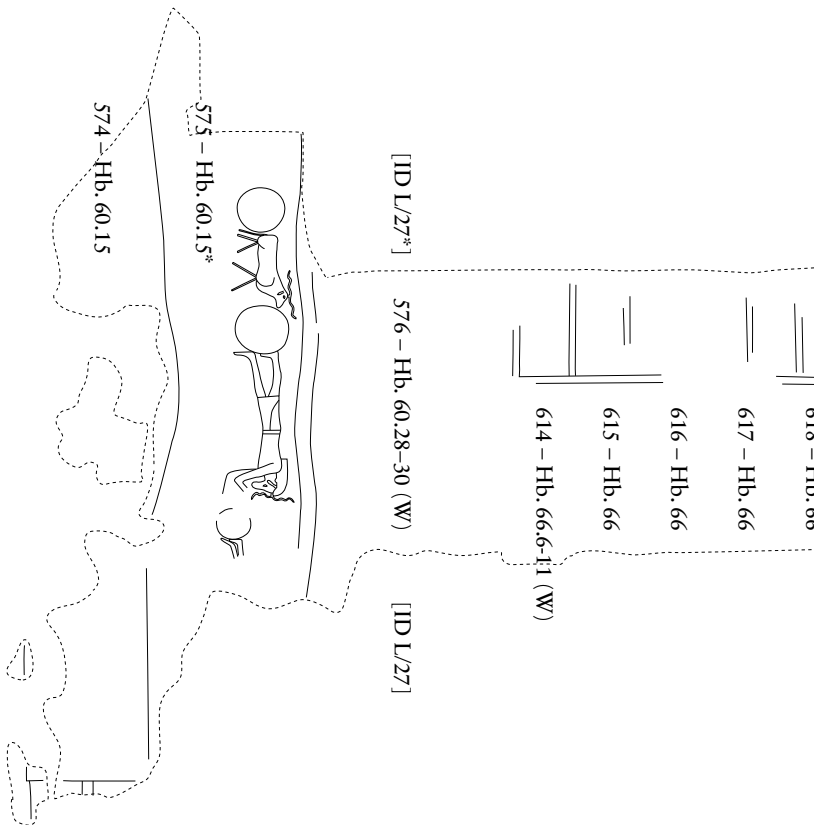

Hb. 60.2-10, Sz. L
(zerstört)

Hb. Sz. L, 60.1/1*
(zerstört)

Hb. 60.15/15*, Sz. L
(DOI 10.17171/2-8-43)

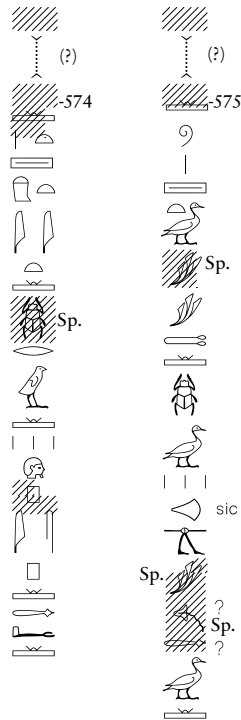

Hb. 60.11*/11-14, Sz. L
(DOI 10.17171/2-8-43)

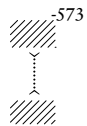

Hb. 60.27*/28-30/27, Sz. L
(DOI 10.17171/2-8-43)



Hb. 60.31-35
(DOI 10.17171/2-8-131)

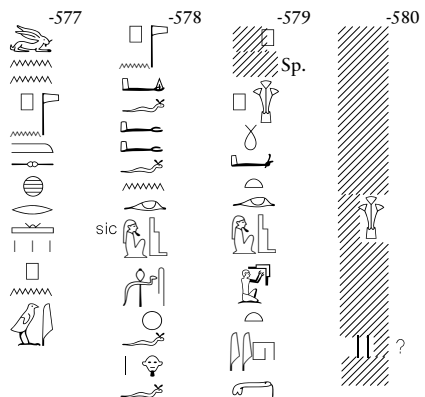



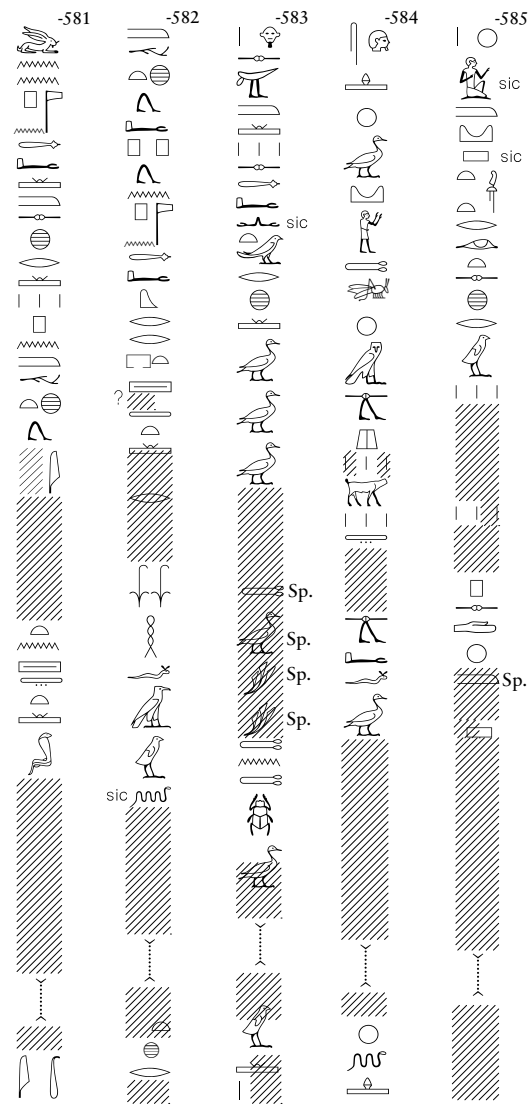

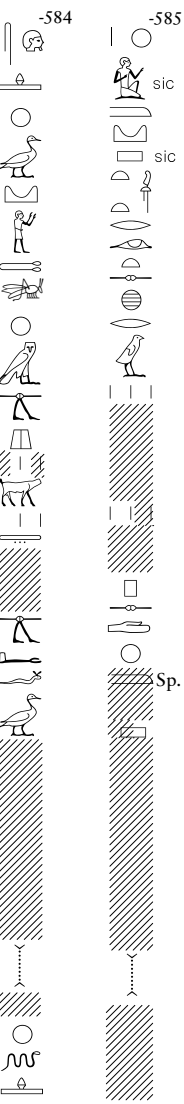

Hb. 60.20-26
(DOI 10.17171/2-8-131)



Hb. 60.16*-19*/16-19
(DOI 10.17171/2-8-131)



592 - Hb. 61	
591 - Hb. 61	
590 - Hb. 61	
589 - Hb. 61	
588 - Hb. 61	
587 - Hb. 61.19-31 (R)	
ID LI/8* ID LI/9*	
ID LI/6* ID LI/7*	
ID LI/4* ID LI/5*	
ID LI/2* ID LI/3*	
Sz. LI	
	
	586 - Hb. 61.12 (W)

Hb. 61.(10-12)
(DOI 10.17171/2-8-44)

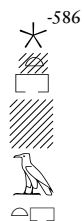

Hb. Sz. LI
(DOI 10.17171/2-8-44)

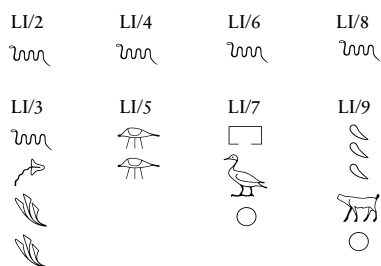

Hb. 61.19-31 (DOI 10.17171/2-8-132)

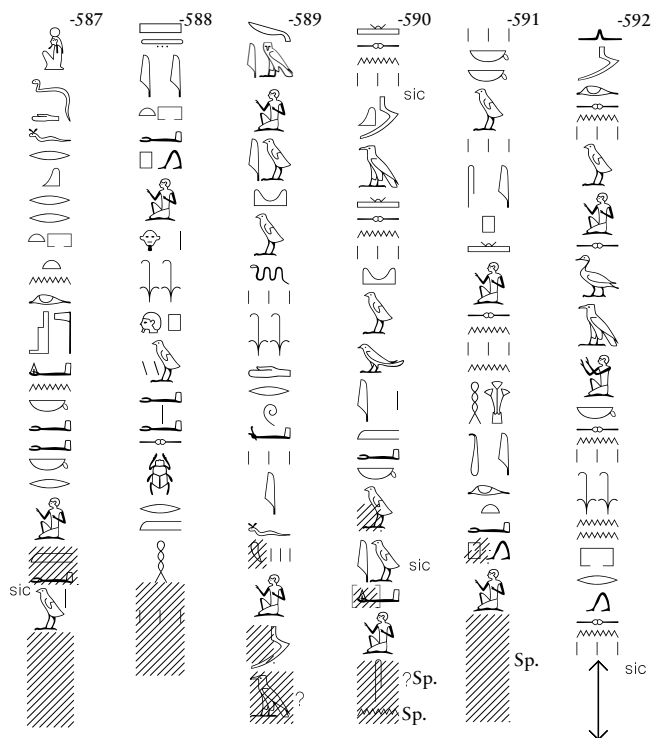

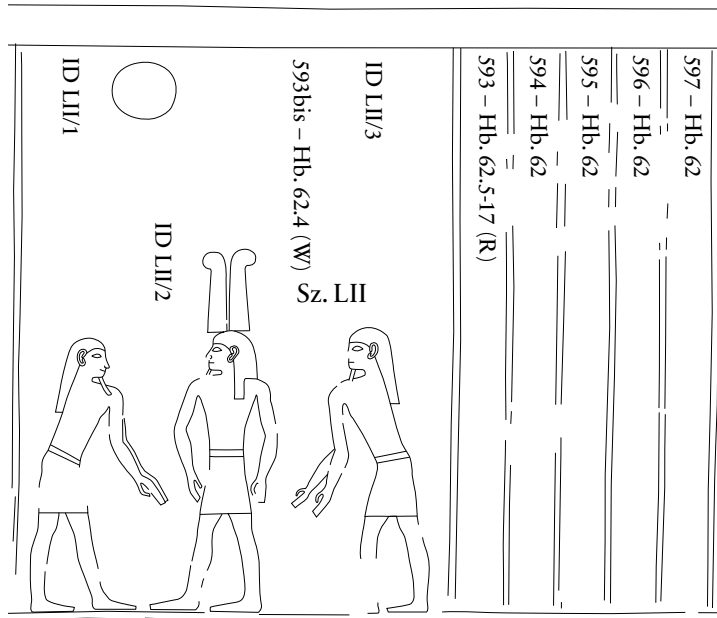

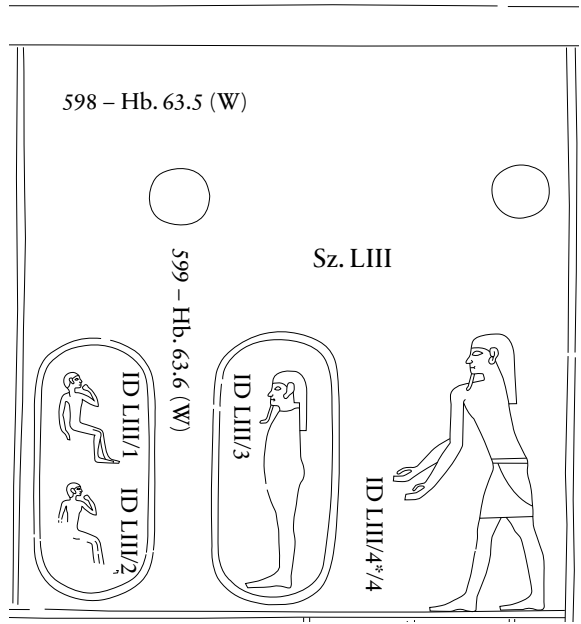

Hb. Sz. LIII, Hb. 63.1-6 (DOI 10.17171/2-8-46)

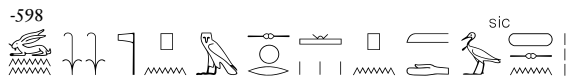

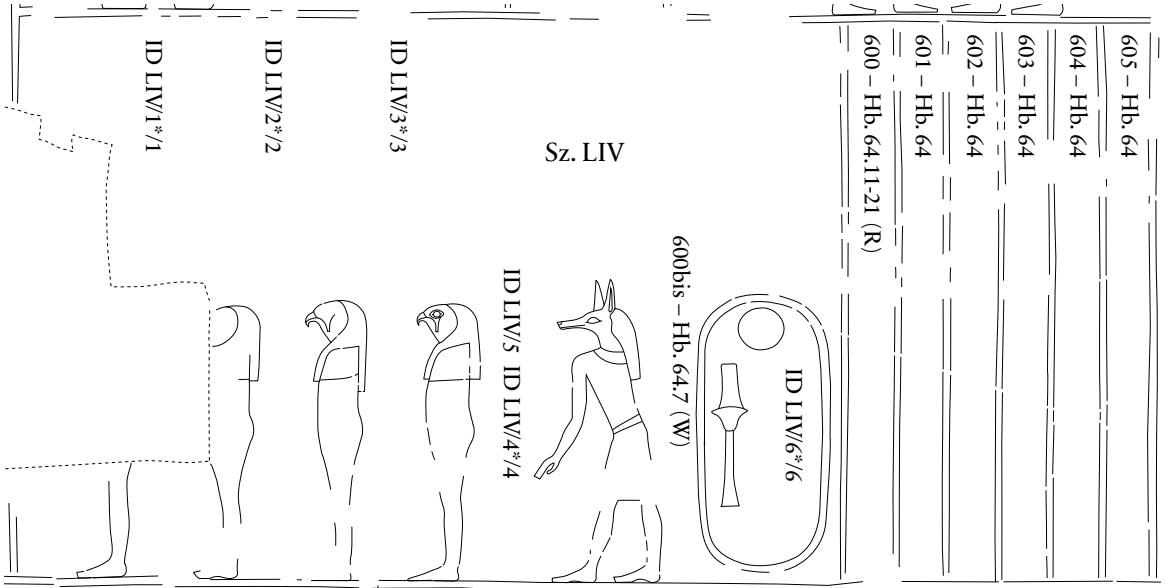

Hb. Sz. LIV (DOI 10.17171/2-8-47)

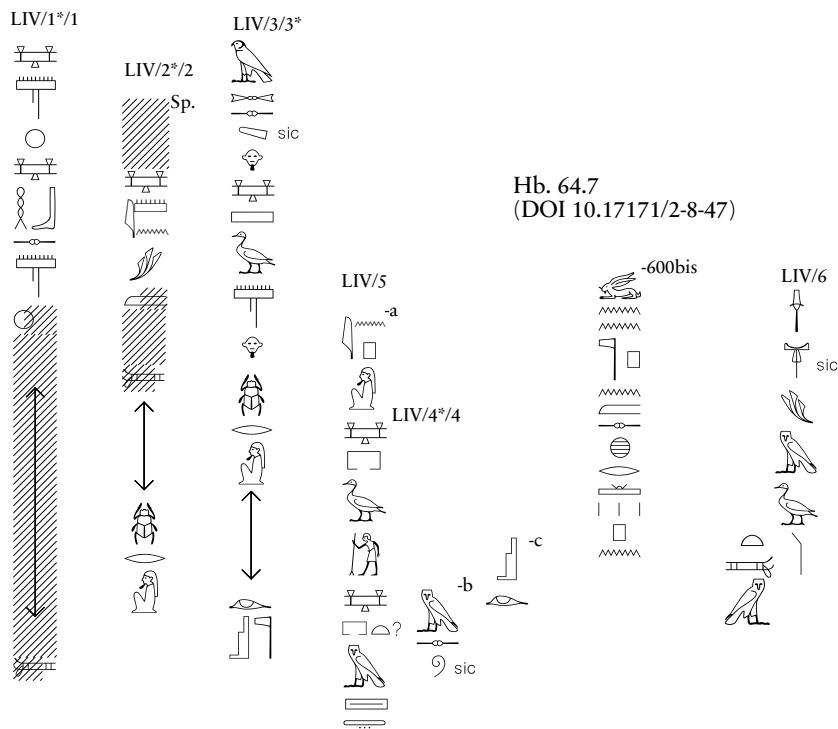

Hb. 64.11-21 (DOI 10.17171/2-8-135)

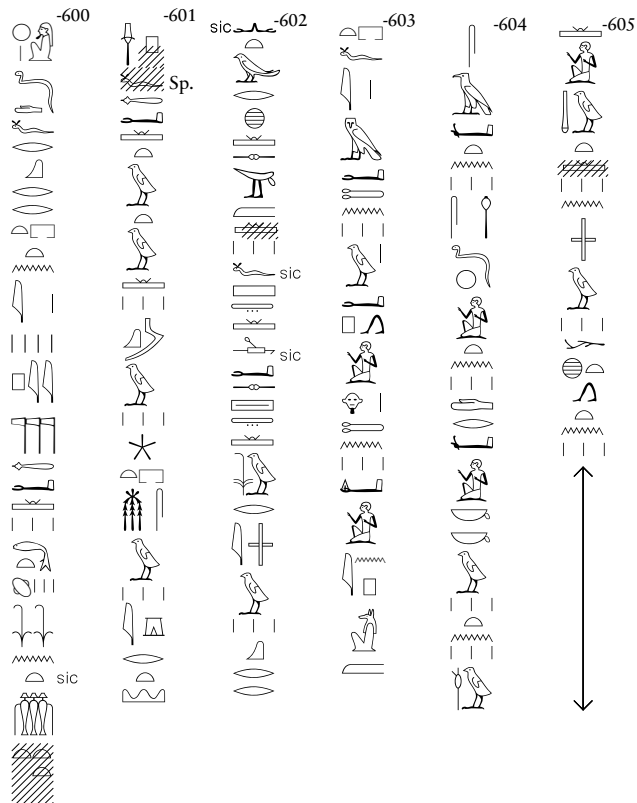

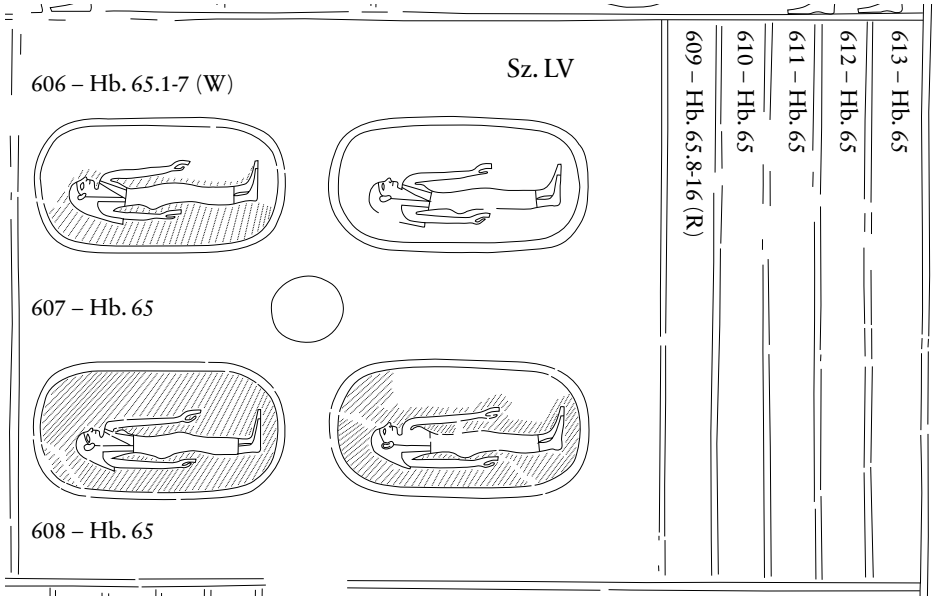

Hb. 65.1-7, Sz. LV (DOI 10.17171/2-8-48)

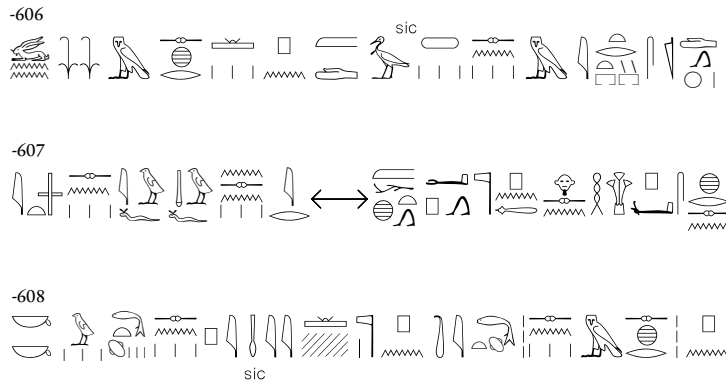

Hb. 65.8-16 (DOI 10.17171/2-8-136)

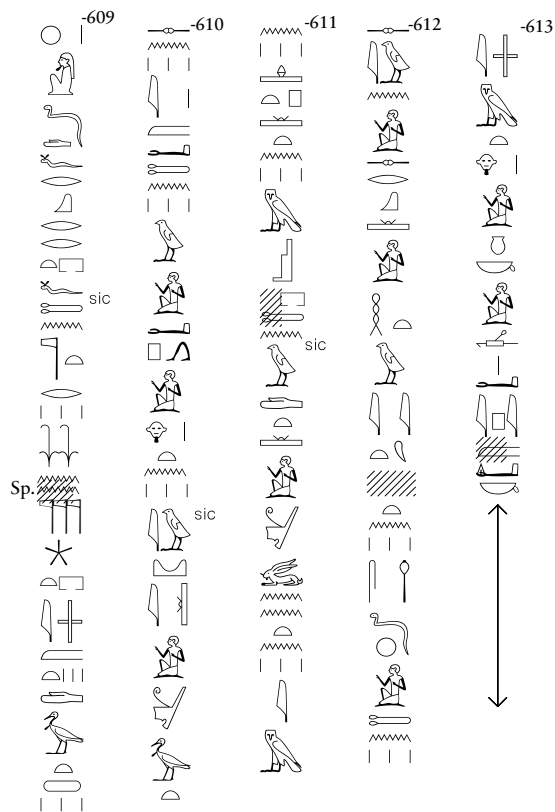

626 – Hb. 66	
625 – Hb. 66	
624 – Hb. 66	
623 – Hb. 66	
622 – Hb. 66, 12-23 (R)	
621 – Hb. 66	
620 – Hb. 66	
619 – Hb. 66	
618 – Hb. 66	
617 – Hb. 66	
616 – Hb. 66	
615 – Hb. 66	
614 – Hb. 66, 6-11 (W)	

Sz. LVI

Hb. 66.6-11, Sz. LVI (DOI 10.17171/2-8-49)

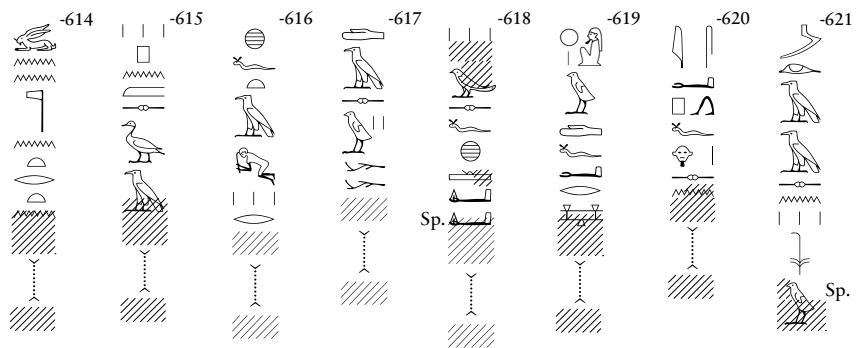

Hb. Sz. LVI
(zerstört)

Hb. 66.12-23 (DOI 10.17171/2-8-137)

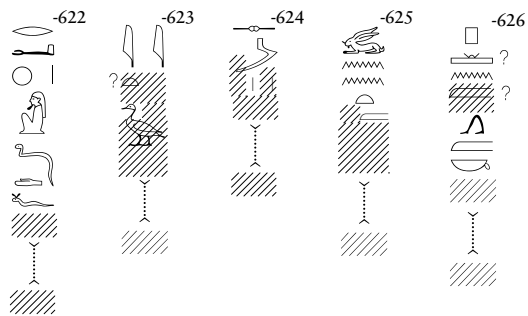

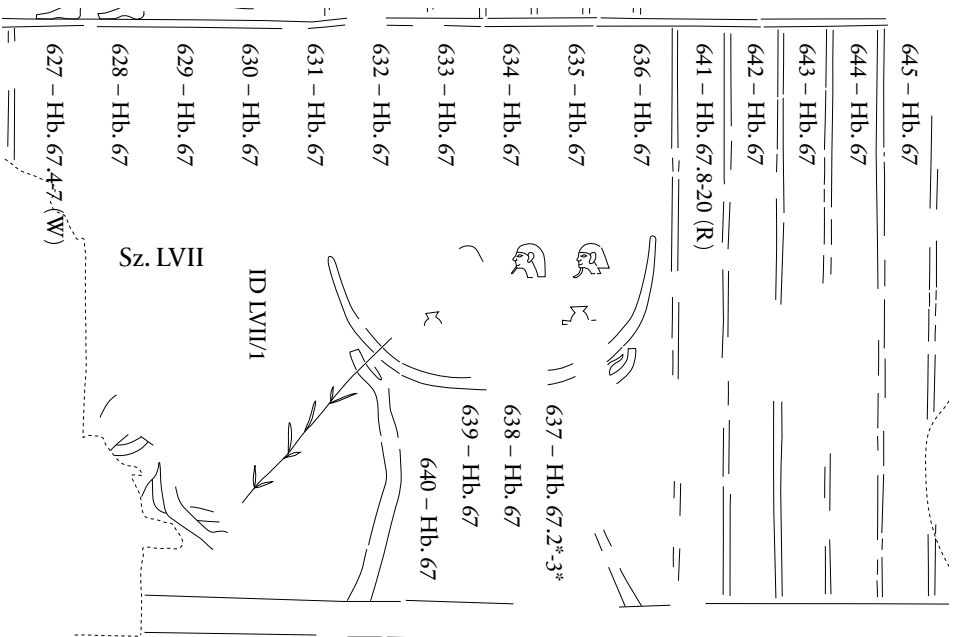

Hb. 67.4-7 (DOI 10.17171/2-8-50)

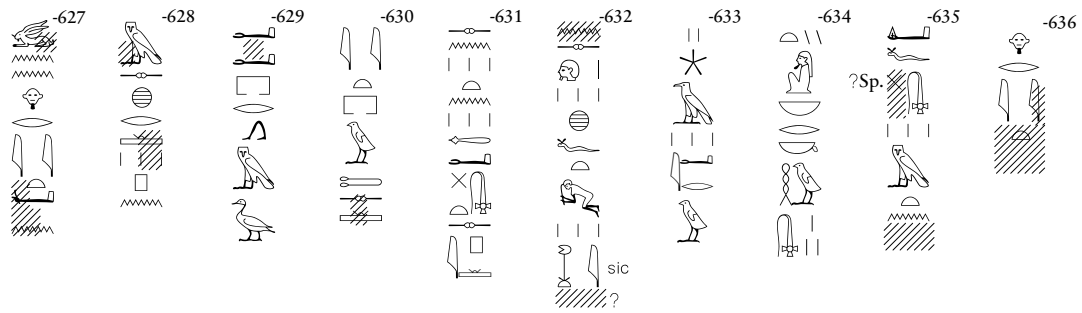

Hb. Sz. LVII
(DOI 10.17171/2-8-50)

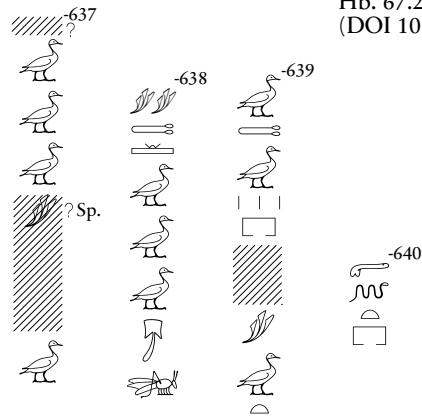

Hb. 67.2*-3*
(DOI 10.17171/2-8-50)

Hb. 67.8-20 (DOI 10.17171/2-8-138)

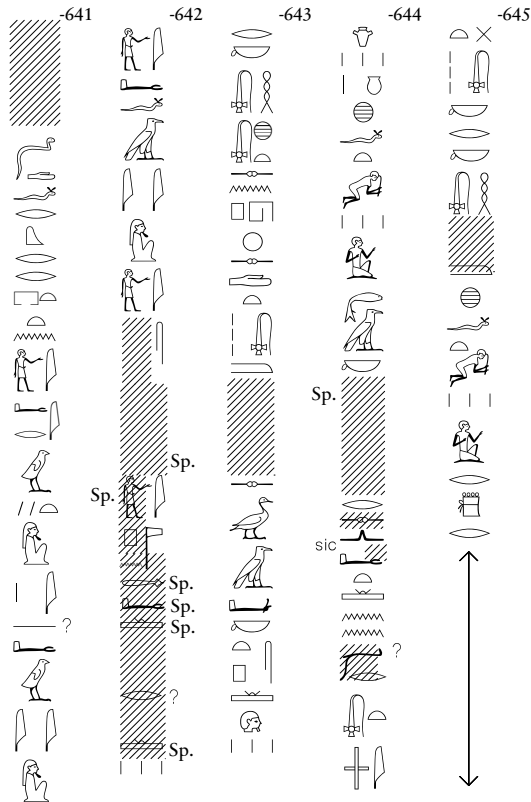

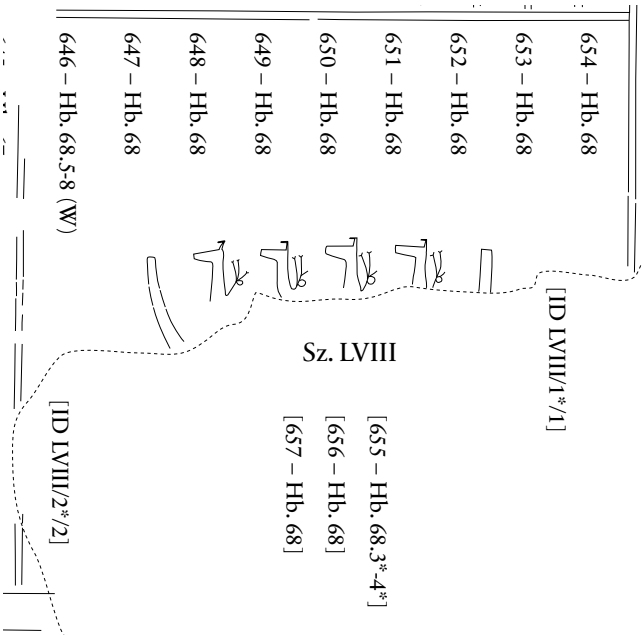

654 - Hb. 68

653 - Hb. 68

652 - Hb. 68

651 - Hb. 68

650 - Hb. 68

649 - Hb. 68

648 - Hb. 68

647 - Hb. 68

646 - Hb. 68, 5-8 (W)

[ID LVIII/1*/1]

Sz. LVIII

[555 - Hb. 68, 3*-4*]

[556 - Hb. 68]

[557 - Hb. 68]

[ID LVIII/2*/2]

Hb. 68.5-8 (DOI 10.17171/2-8-139)

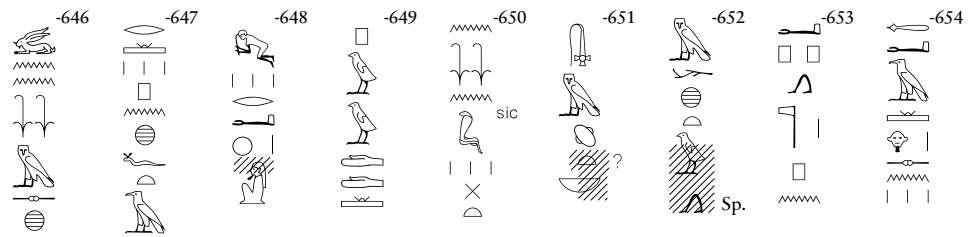
Hb. Sz. LVIII (DOI 10.17171/2-8-51)
(teilweise zerstört)Hb. 68.3*-4*
(zerstört)

Kolumnen 655-657 zerstört.

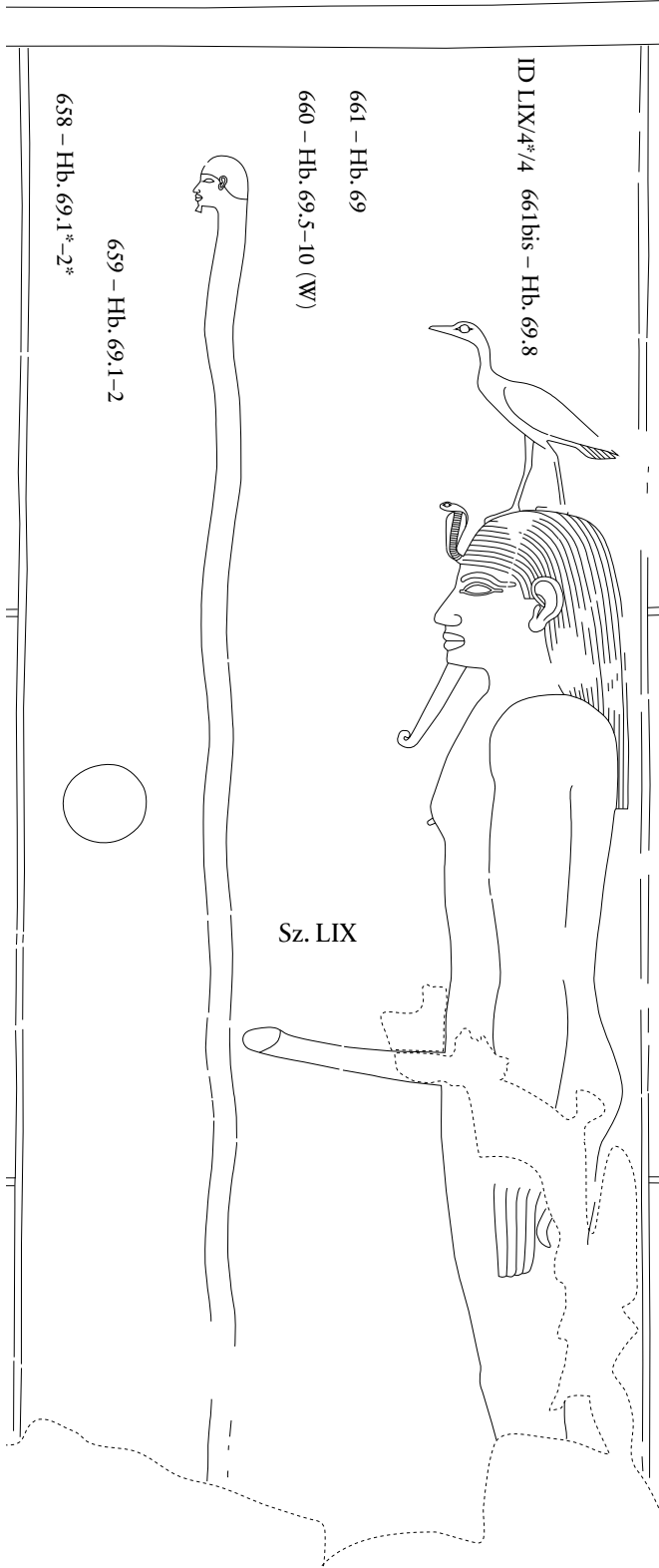

ID LIX/4*/4 661bis - Hb. 69.8

661 - Hb. 69

660 - Hb. 69.5-10 (W)

Sz. LIX

659 - Hb. 69.1-2

658 - Hb. 69.1*-2*



Hb. 69.1*-2*,1-2
(DOI 10.17171/2-8-52)

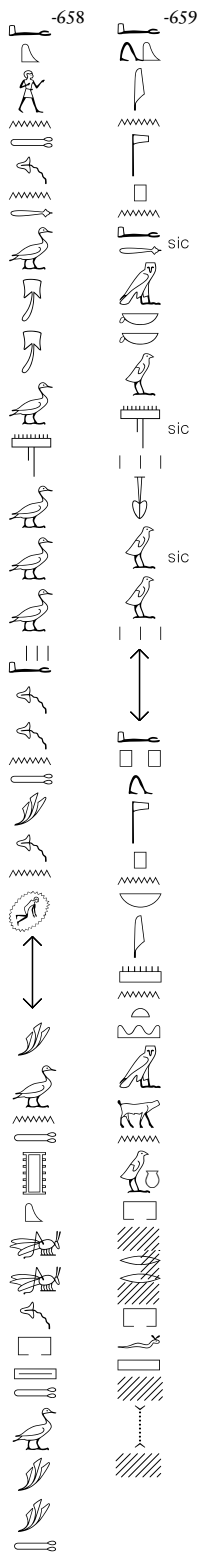

Hb. 69.5-10
(DOI 10.17171/2-8-52)

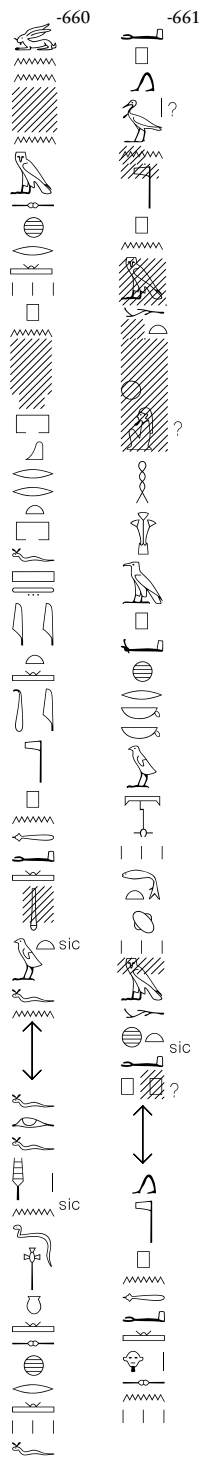

Hb. Sz. LIX
(DOI 10.17171/2-8-52)

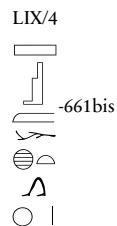

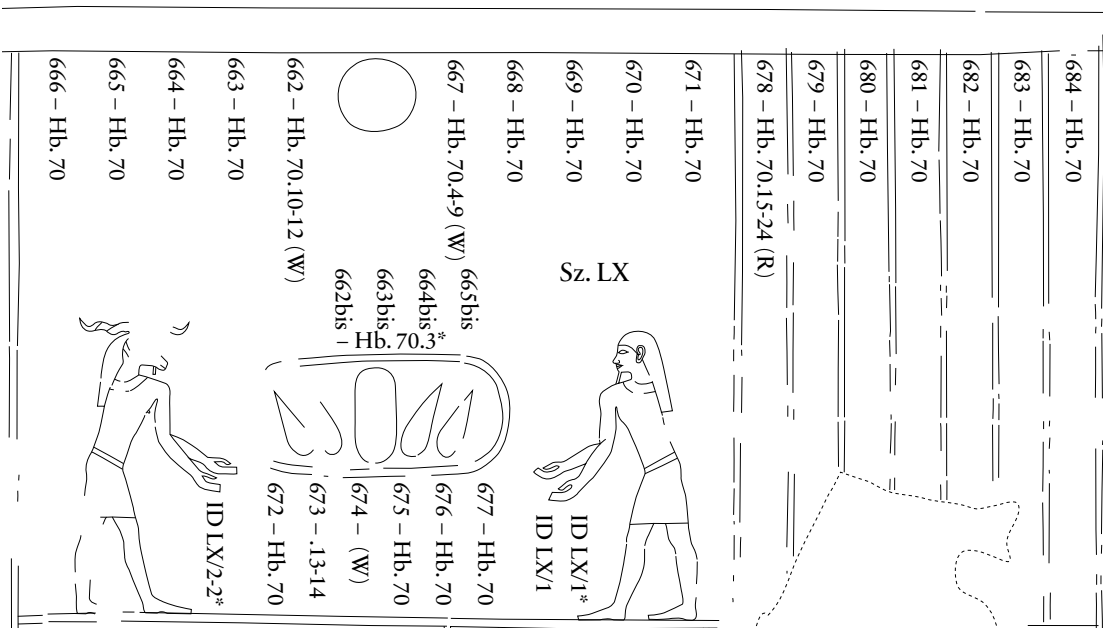

Hb. 70.10-12 (DOI 10.17171/2-8-53)

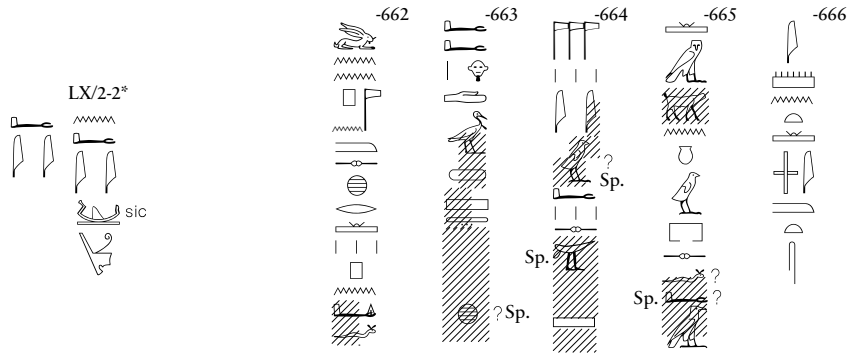

Hb. Sz. LX
(DOI 10.17171/2-8-53)

Hb. 70.4-9 (DOI 10.17171/2-8-53)

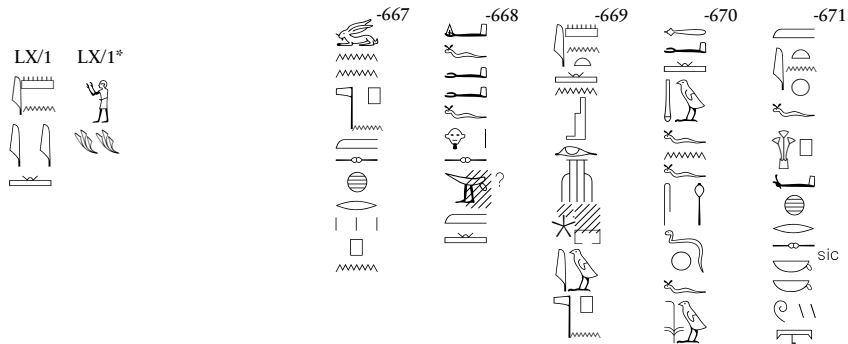

Hb. 70.3* (DOI 10.17171/2-8-53)

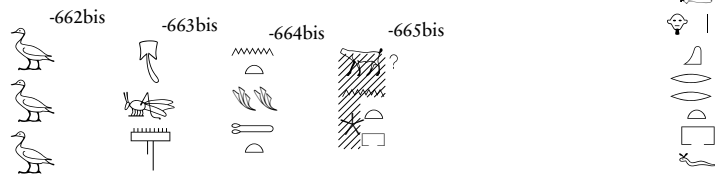

Hb. 70.13-14 (DOI 10.17171/2-8-53)

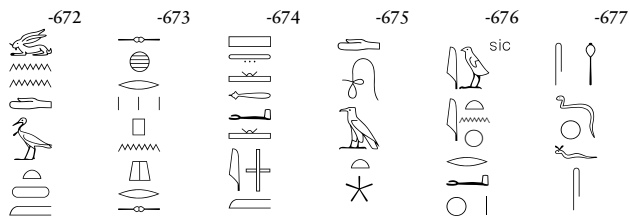

Hb. 70.13-24 (DOI 10.17171/2-8-141)

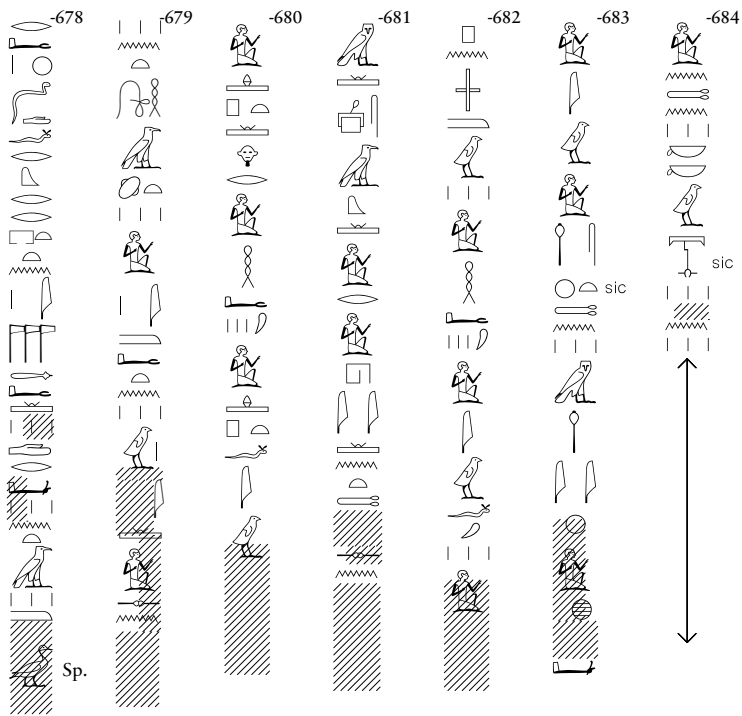

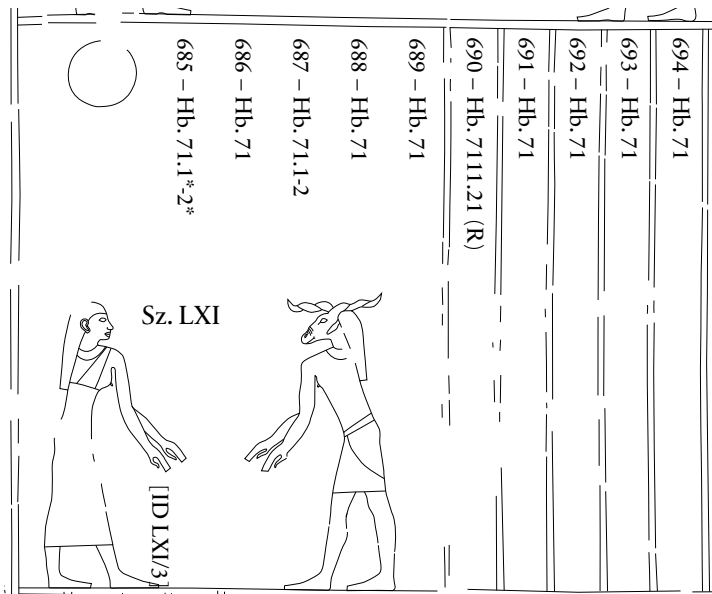

Hb. 71.1-2,1*-2*, Sz. LXI (DOI 10.17171/2-8-54)

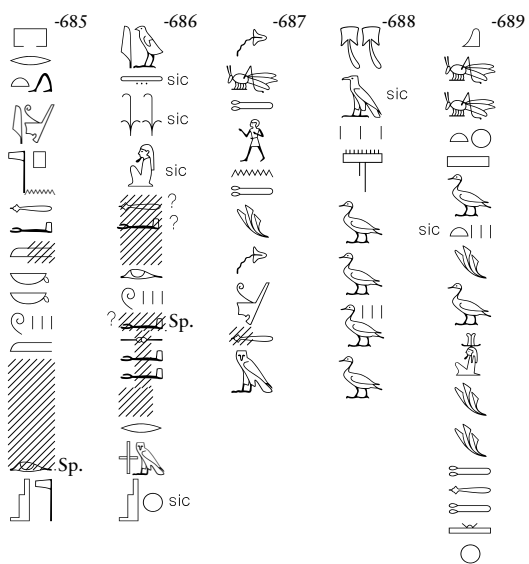

Hb. 71.11-21 (DOI 10.17171/2-8-142)

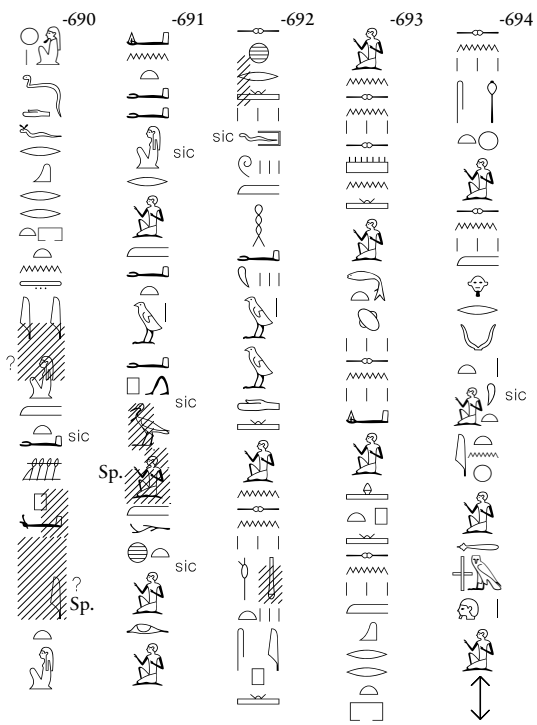

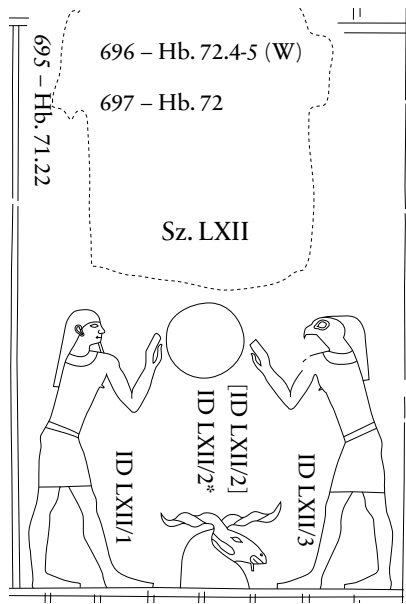

Hb. 71.22
(DOI 10.17171/2-8-55)

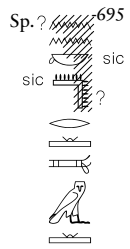

Hb. 72.4-5 (DOI 10.17171/2-8-55)

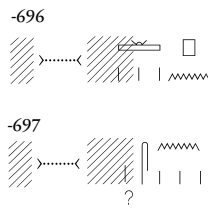

Hb. Sz. LXII, Hb. 72 (DOI 10.17171/2-8-55)

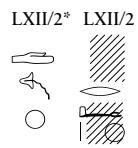

LXII/1



LXII/3



716 – Hb.73	
715 – Hb.73	
714 – Hb.73	
713 – Hb.73	
712 – Hb.73	
711 – Hb.73	
710 – Hb.73	
709 – Hb.73	
708 – Hb.73	
707 – Hb.73	
706 – Hb.73	
705 – Hb.73	
704 – Hb.73	
703 – Hb.73	
702 – Hb.73.8-18 (R)	
701 – Hb.73	
700 – Hb.73	
699 – Hb.73	
698 – Hb.73.5-7 (W)	

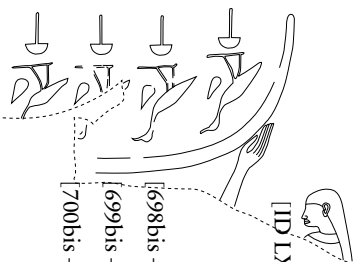

[ID LXIII/2*/2]

[698bis – Hb.73.4*]

[699bis – Hb.73]

[700bis – Hb.73]

Sz. LXIII

[ID LXIII/1*1]

Hb. 73.5-7 (DOI 10.17171/2-8-56)

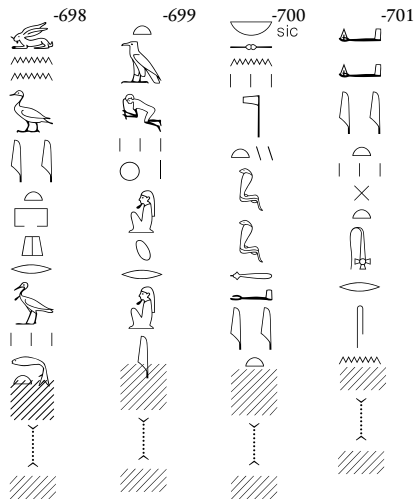

Hb. Sz. LXIII (DOI 10.17171/2-8-56)
(teilweise zerstört)

Hb. 73.8-18 (DOI 10.17171/2-8-144)

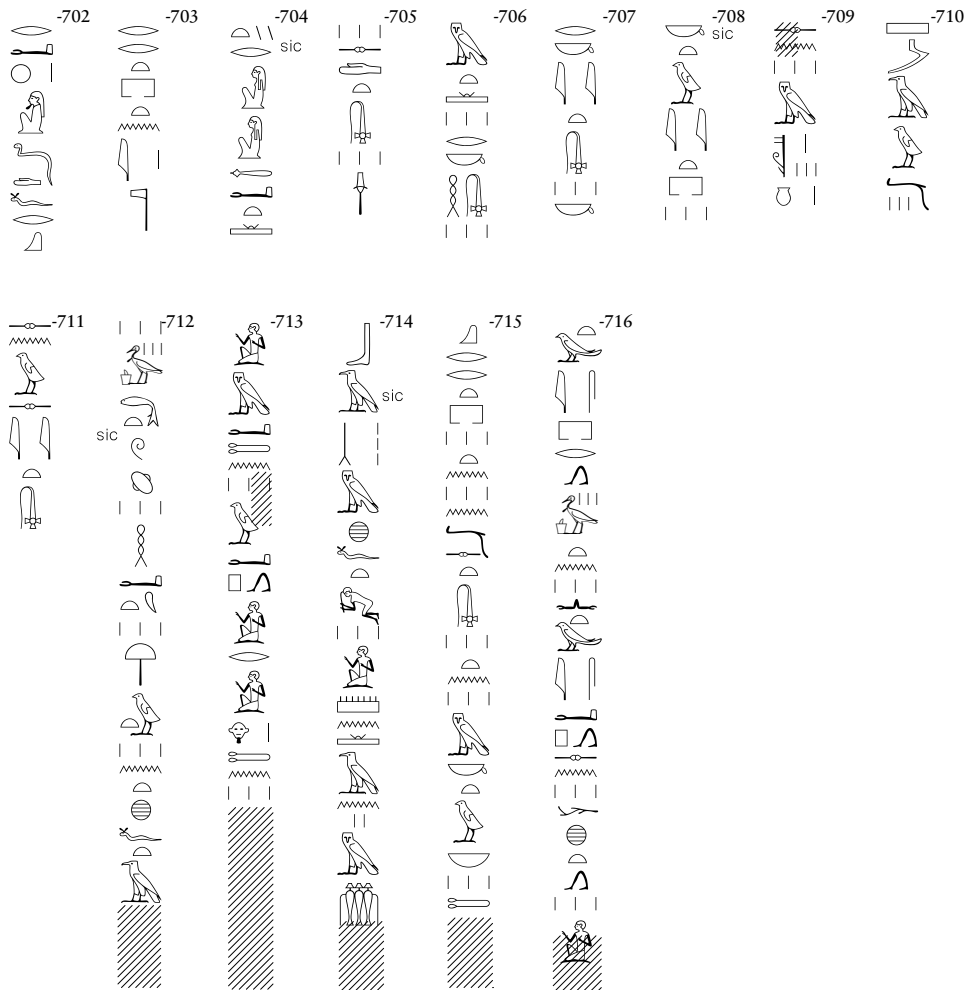

781 - Hb. 77 (Schluss)-78 (Einleitung)			
773 - Hb. 77 (Lit. 10.8)		780 - Hb. 77 (Lit. 10.14)	
772 - Hb. 77 (Lit. 10.7)		779 - Hb. 77 (Lit. 10.5)	
771 - Hb. 77 (Lit. 10.6)		778 - Hb. 77 (Lit. 10.13)	
770 - Hb. 77 (Lit. 10.4)		777 - Hb. 77 (Lit. 10.12)	
769 - Hb. 77 (Lit. 10.3)		776 - Hb. 77 (Lit. 10.11)	
768 - Hb. 77 (Lit. 10.2)		775 - Hb. 77 (Lit. 10.10)	
767 - Hb. 77 (Lit. 10.1)		774 - Hb. 77 (Lit. 10.9)	
766 - Hb. 77 (Einleitung)			
765 - Hb. 76-77 (Einleitung)			
764 - Hb. 76 (Schluss)			
750 - Hb. 76 (Lit. 9.7)		763 - Hb. 76 (Schluss)	
749 - Hb. 76 (Lit. 9.6)		756 - Hb. 76 (Schluss)	
748 - Hb. 76 (Lit. 9.5)		755 - Hb. 76 (Lit. 9.12)	
747 - Hb. 76 (Lit. 9.4)		754 - Hb. 76 (Lit. 9.11)	
746 - Hb. 76 (Lit. 9.3)		753 - Hb. 76 (Lit. 9.10)	
745 - Hb. 76 (Lit. 9.2)		752 - Hb. 76 (Lit. 9.9)	
744 - Hb. 76 (Lit. 9.1)		751 - Hb. 76 (Lit. 9.8)	
743 - Hb. 76 (Einleitung)			
737 - Hb. 75 (Lit. 8.5)		742 - Hb. 75 (Schluss)-76 (Einleitung)	
736 - Hb. 75 (Lit. 8.4)		741 - Hb. 75 (Schluss)	
735 - Hb. 75 (Lit. 8.3)		740 - Hb. 75 (Schluss)	
734 - Hb. 75 (Lit. 8.2)		739 - Hb. 75 (Schluss)	
733 - Hb. 75 (Lit. 8.1)		738 - Hb. 75 (Schluss)	
725 - Hb. 74 (Lit. 7.8)		732 - Hb. 75 (Einleitung-Lit. 8.1)	
724 - Hb. 74 (Lit. 7.7)		731 - Hb. 74 (Schluss)-75 (Einleitung)	
723 - Hb. 74 (Lit. 7.6)		730 - Hb. 74 (Schluss)	
722 - Hb. 74 (Lit. 7.4)		729 - Hb. 74 (Schluss)	
721 - Hb. 74 (Lit. 7.3)		728 - Hb. 74 (Schluss)	
720 - Hb. 74 (Lit. 7.2)		727 - Hb. 74 (Schluss)	
719 - Hb. 74 (Einleitung-Lit. 7.1)		726 - Hb. 74 (Schluss)	
718 - Hb. 74 (Einleitung)			
717 - Hb. 74 (Einleitung)			

834 - Hb. 81 (Einleitung)		833 - Hb. 81 (Einleitung)	
840 - Hb. 80 (Lit. 14.9)		852 - Hb. 80 (Schluss) - 81 (Einleitung)	
839 - Hb. 80 (Lit. 14.8)		851 - Hb. 80 (Schluss)	
838 - Hb. 80 (Lit. 14.7)		845 - Hb. 80 (Lit. 14.2)	850 - Hb. 80
837 - Hb. 80 (Lit. 14.6)		844 - Hb. 80 (Lit. 14.13)	849 - (Schl.)
836 - Hb. 80 (Lit. 14.5)		843 - Hb. 80 (Lit. 14.12)	848 - Hb. 80
835 - Hb. 80 (Lit. 14.4)		842 - Hb. 80 (Lit. 14.11)	847 - (Schl.)
834 - Hb. 80 (Lit. 14.3)		841 - Hb. 80 (Lit. 14.10)	846 - Hb. 80
833 - Hb. 80 (Lit. 14.1)			

888 – Hb. 81 (Schluss) – 82 (Einleitung)	
887 – Hb. 81 (Schlusstext)	
886 – Hb. 81 (Schlusstext)	
885 – Hb. 81 (Schlusstext)	
884 – Hb. 81 (Lit. 16, Schlusswers)	
883 – Hb. 81 (Lit. 16, 12)	
882 – Hb. 81 (Lit. 16, 11)	
881 – Hb. 81 (Lit. 16, 10)	
880 – Hb. 81 (Lit. 16, 9)	
879 – Hb. 81 (Lit. 16, 8)	
878 – Hb. 81 (Lit. 16, 7)	
877 – Hb. 81 (Lit. 16, 6)	
876 – Hb. 81 (Lit. 16, 5)	
875 – Hb. 81 (Lit. 16, 4)	
874 – Hb. 81 (Lit. 16, 3)	
873 – Hb. 81 (Lit. 16, 2)	
872 – Hb. 81 (Lit. 16, 1)	
871 – Hb. 81 (Überleitungsvers)	
870 – Hb. 81 (Lit. 15, 13)	
869 – Hb. 81 (Lit. 15, 12)	
868 – Hb. 81 (Lit. 15, 11)	
867 – Hb. 81 (Lit. 15, 10)	
866 – Hb. 81 (Lit. 15, 9)	
865 – Hb. 81 (Lit. 15, 8)	
864 – Hb. 81 (Lit. 15, 5, Wiederholung)	
863 – Hb. 81 (Lit. 15, 7)	
862 – Hb. 81 (Lit. 15, 6)	
861 – Hb. 81 (Lit. 15, 5)	
860 – Hb. 81 (Lit. 15, 4)	
859 – Hb. 81 (Lit. 15, 3)	
858 – Hb. 81 (Lit. 15, 2)	
857 – Hb. 81 (Lit. 15, 1)	
856 – Hb. 81 (Einleitung) + NN	
855 – Hb. 81 (Einleitung)	
854 – Hb. 81 (Einleitung)	
840 – Hb. 80 (Lit. 14, 9)	

951 – Hb. 83 (Schlusstext)	
956 – Hb. 83 (Lit. 18.14)	950 – (Schluss)
935 – Hb. 83 (Lit. 18.13)	949 – Hb. 83
934 – Hb. 83 (Lit. 18.12)	948 – (Schluss)
933 – Hb. 83 (Lit. 18.11)	947 – Hb. 83
932 – Hb. 83 (Lit. 18.10)	946 – (Schluss)
931 – Hb. 83 (Lit. 18.9)	945 – Hb. 83
930 – Hb. 83 (Lit. 18.8)	944 – (Schluss)
929 – Hb. 83 (Lit. 18.7)	943 – Hb. 83
928 – Hb. 83 (Lit. 18.6)	942 – (Schluss)
927 – Hb. 83 (Lit. 18.5)	941 – Hb. 83
926 – Hb. 83 (Lit. 18.4)	940 – (Schluss)
925 – Hb. 83 (Lit. 18.3)	939 – Hb. 83
924 – Hb. 83 (Lit. 18.2)	938 – (Schluss)
923 – Hb. 83 (Lit. 18.1)	937 – Hb. 83
922 – Hb. 83 (Einleitung)	
921 – Hb. 83 (Einleitung)	
920 – Hb. 82 (Schluss) – 83 (Einleitung)	
905 – Hb. 82 (Lit. 17.14)	919 – (Schluss)
904 – Hb. 82 (Lit. 17.13)	918 – Hb. 82
903 – Hb. 82 (Lit. 17.12)	917 – (Schluss)
902 – Hb. 82 (Lit. 17.11)	916 – Hb. 82
901 – Hb. 82 (Lit. 17.10)	915 – (Schluss)
900 – Hb. 82 (Lit. 17.9)	914 – Hb. 82
899 – Hb. 82 (Lit. 17.8)	913 – (Schluss)
898 – Hb. 82 (Lit. 17.7)	912 – Hb. 82
897 – Hb. 82 (Lit. 17.6)	911 – (Schluss)
896 – Hb. 82 (Lit. 17.5)	910 – Hb. 82
895 – Hb. 82 (Lit. 17.4)	909 – (Schluss)
894 – Hb. 82 (Lit. 17.3)	908 – Hb. 82
893 – Hb. 82 (Lit. 17.2)	907 – (Schluss)
892 – Hb. 82 (Lit. 17.1)	906 – Hb. 82
891 – Hb. 82 (Einleitung)	
890 – Hb. 82 (Einleitung)	
889 – Hb. 82 (Einleitung)	
888 – Hb. 81 (Schluss) – 82 (Einleitung)	

986 - Hb. 84 (Schluss) - 85 (Einleitung)	
974 - Hb. 84 (Lit. 19.11)	985 - Hb. 84
973 - Hb. 84 (Lit. 19.10)	984 - (Schluss)
972 - Hb. 84 (Lit. 19.9)	983 - Hb. 84
971 - Hb. 84 (Lit. 19.8)	982 - (Schluss)
970 - Hb. 84 (Lit. 19.7)	981 - Hb. 84
969 - Hb. 84 (Lit. 19.6)	980 - (Schluss)
968 - Hb. 84 (Lit. 19.5)	979 - Hb. 84
967 - Hb. 84 (Lit. 19.4)	978 - (Schluss)
966 - Hb. 84 (Lit. 19.3)	977 - Hb. 84
965 - Hb. 84 (Lit. 19.2)	976 - (Schluss)
964 - Hb. 84 (Lit. 19.1)	975 - Hb. 84
963 - Hb. 84 (Einleitung)	
962 - Hb. 84 (Einleitung)	
961 - Hb. 84 (Einleitung)	
960 - Hb. 84 (Einleitung)	
959 - Hb. 84 (Einleitung)	
958 - Hb. 84 (Einleitung)	
957 - Hb. 84 (Einleitung)	
956 - Hb. 83 (Schl.) - 84 (Einleitung)	
955 - Hb. 83 (Schluss)	
954 - Hb. 83 (Schluss)	
953 - (Schluss)	
952	

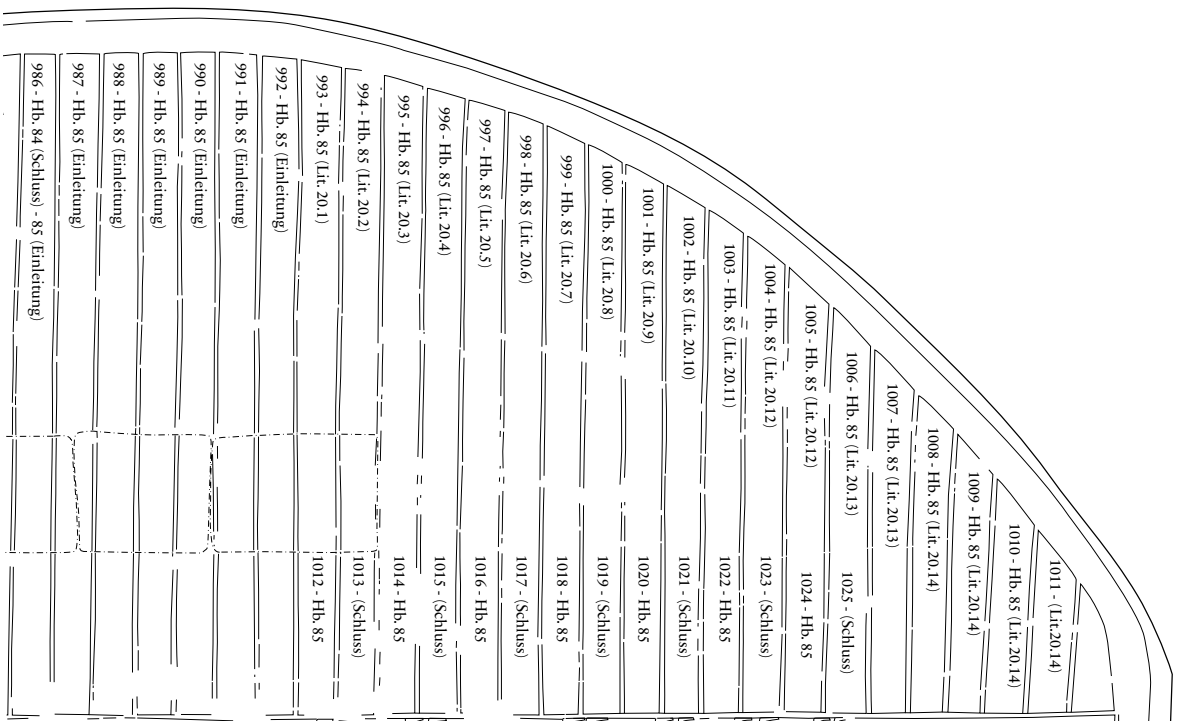

Hb. 74.1-14
(DOI 10.17171/2-8-145)

-717

 -718
 sic

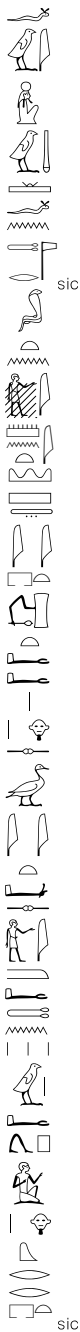
sic

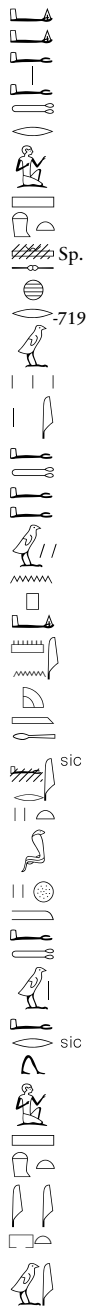
 sic

Sp.

 sic
 sic



Hb. 74.15-38
(DOI 10.17171/2-8-145)

-720

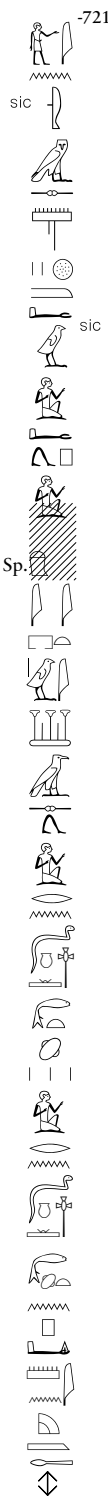
 sic

-721

 sic
 Sp.
 sic

-722

 Sp.

-723

 sic

Hb. 74.39-48
(DOI 10.17171/2-8-145)

Hb. 75.1-16
(DOI 10.17171/2-8-146)

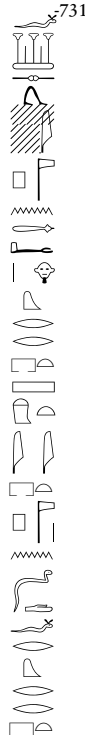
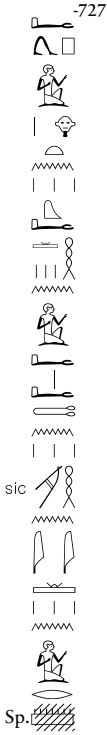

Hb. 75.17-25
(DOI 10.17171/2-8-146)

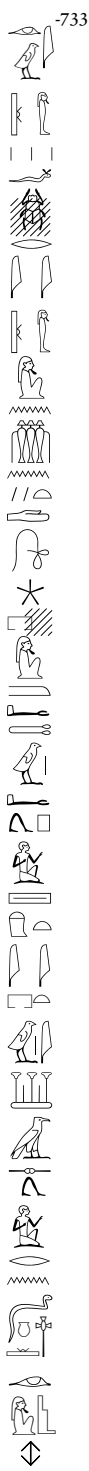
-733

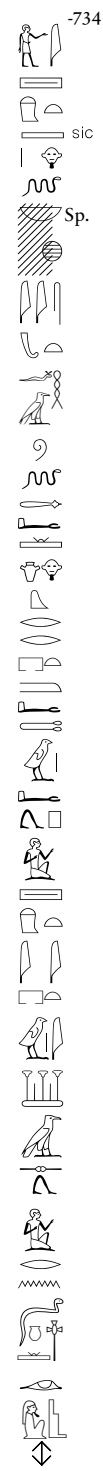
-734
sic
Sp.

-735
Sp.

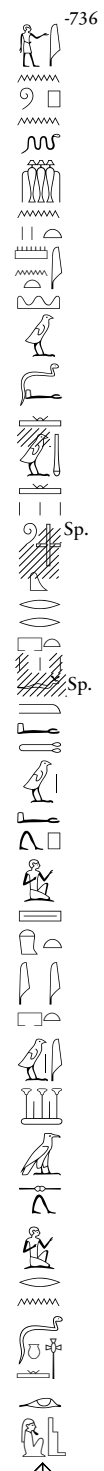
-736
Sp.
Sp.

-737
sic

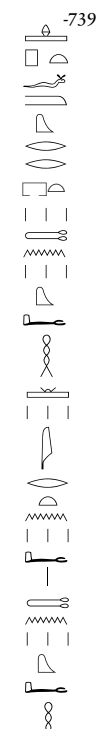

-738

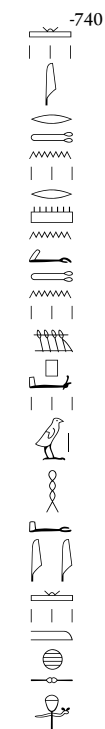
-739

-740

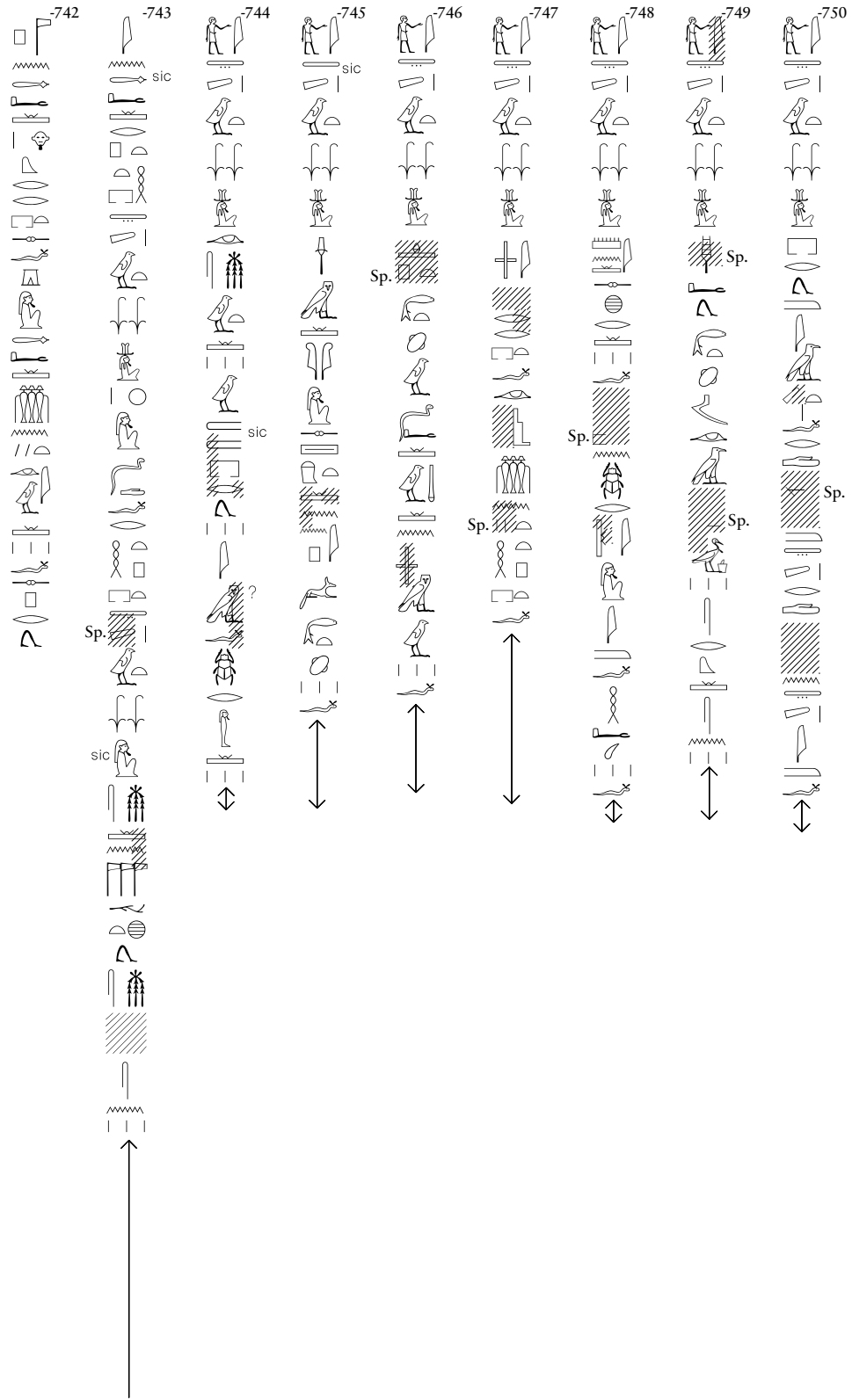
-741

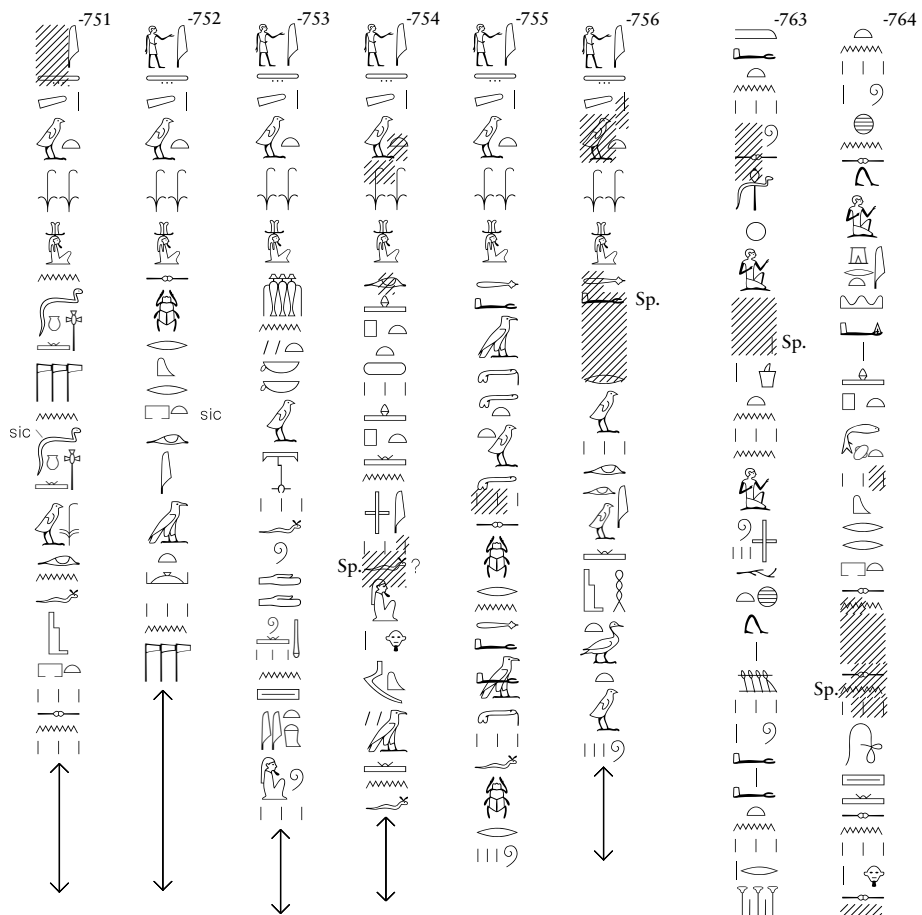



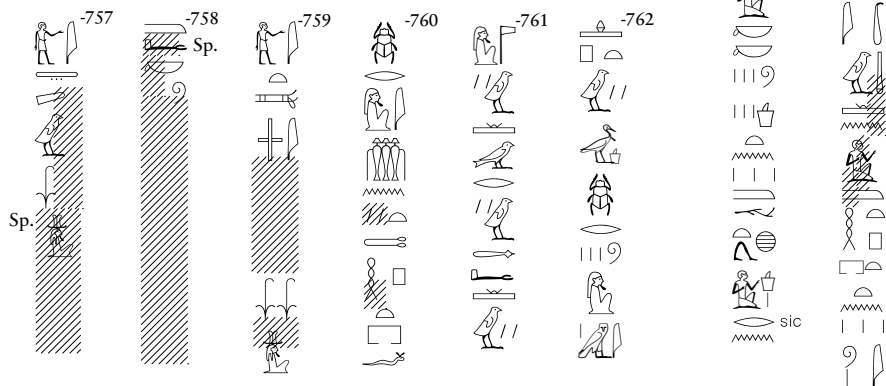

Hb. 76.48-66
(DOI 10.17171/2-8-147)

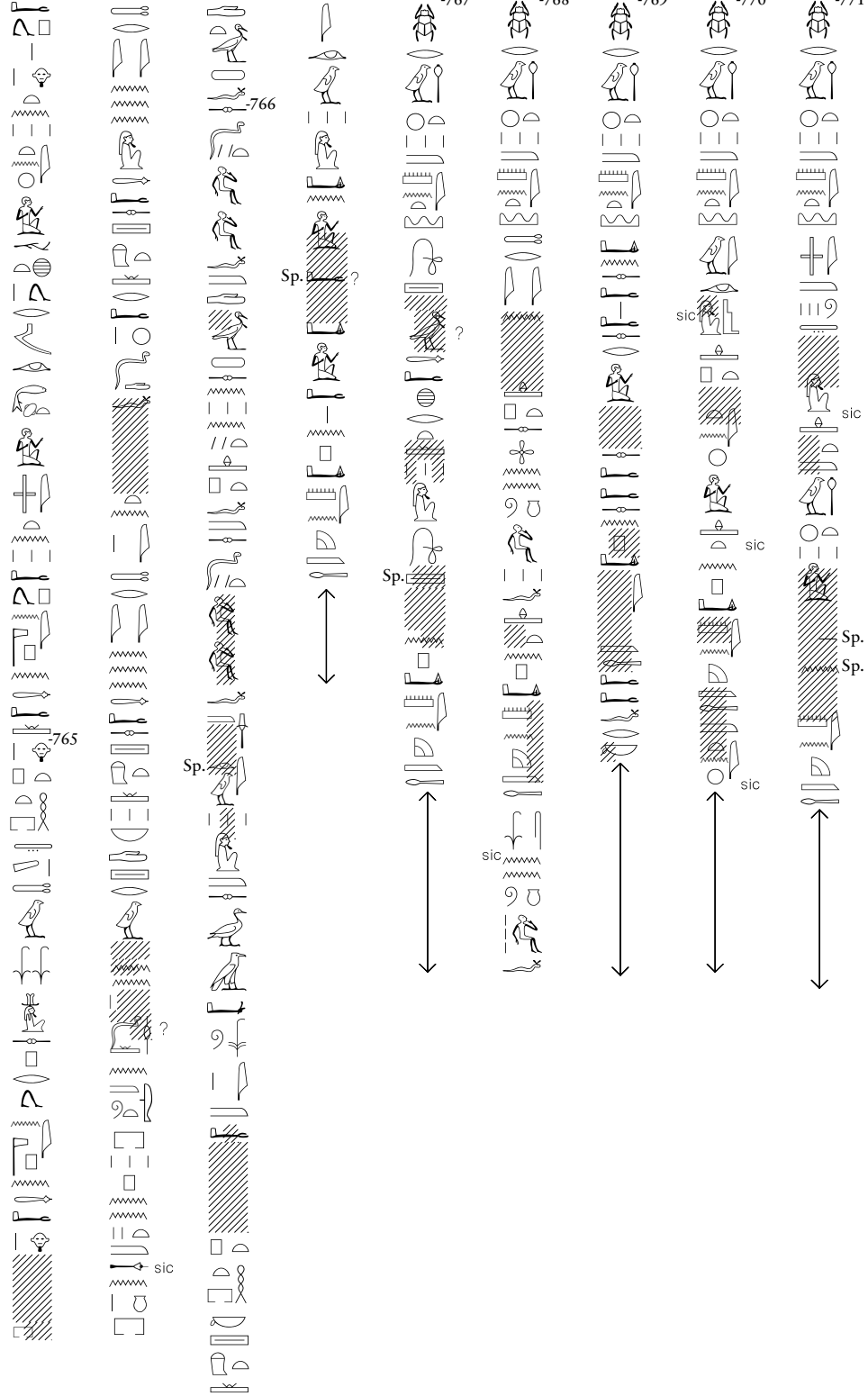

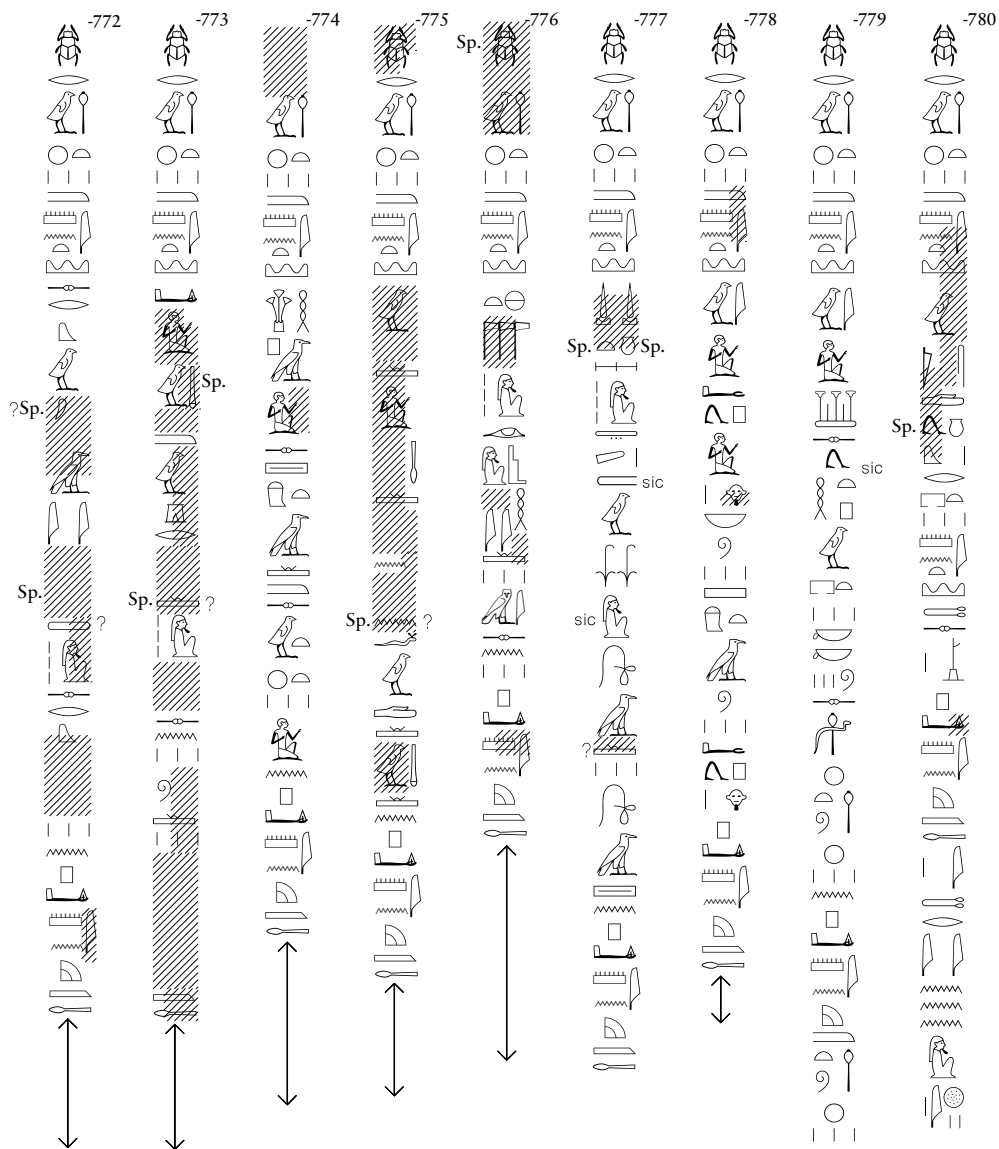



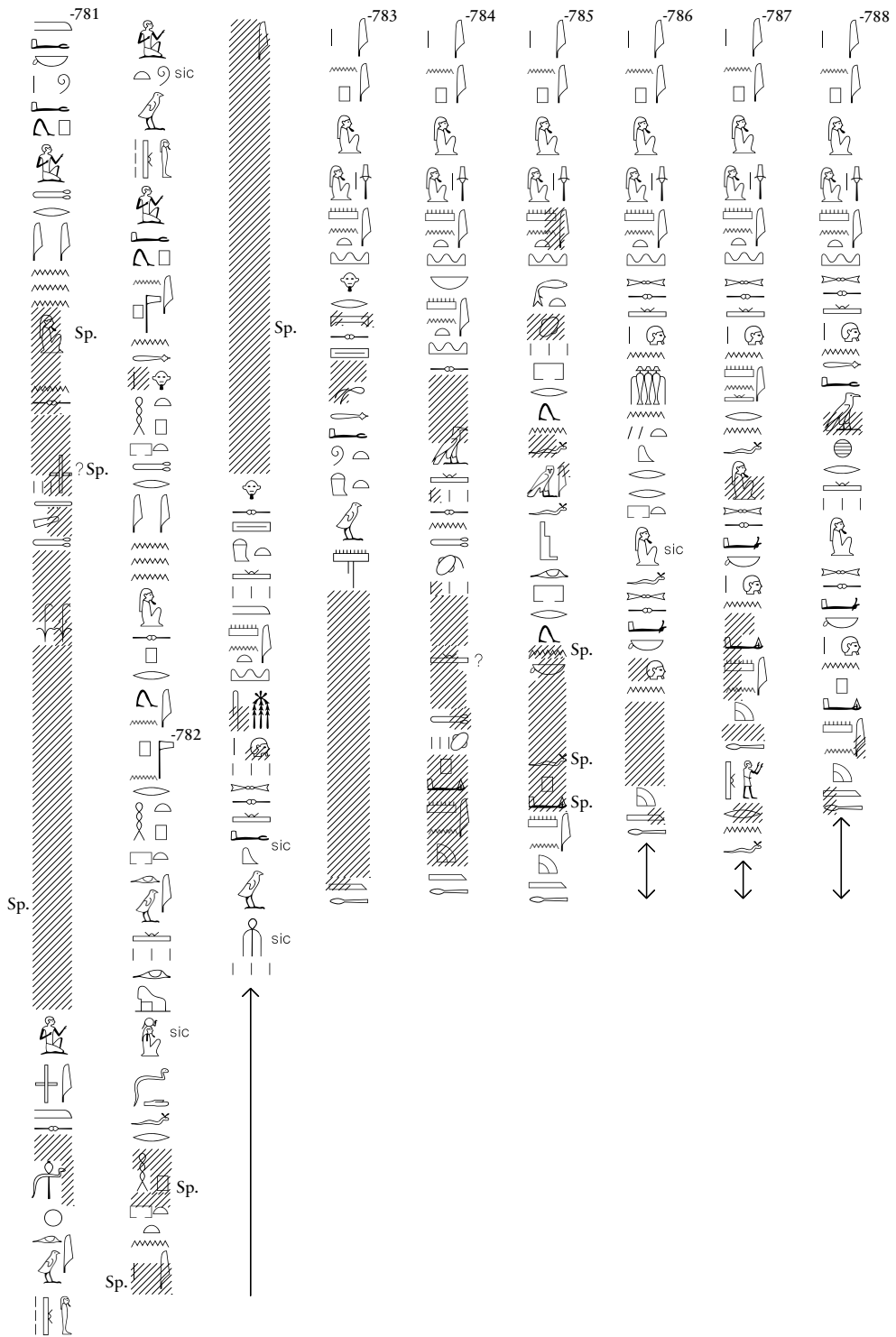

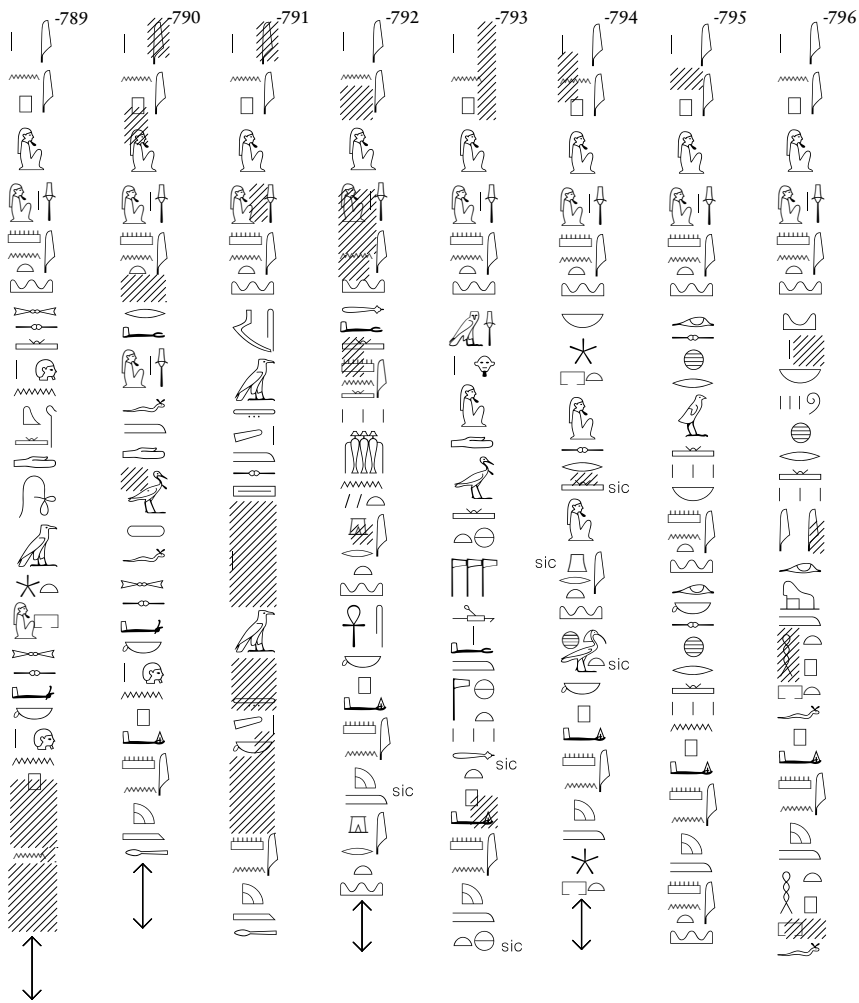

Hb. 79.1-35
(DOI 10.17171/2-8-150)

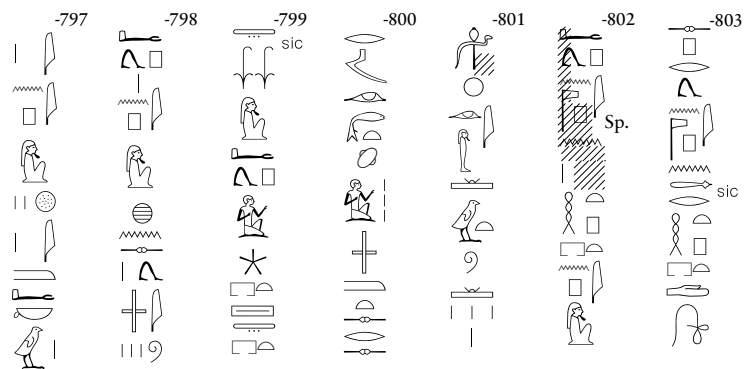

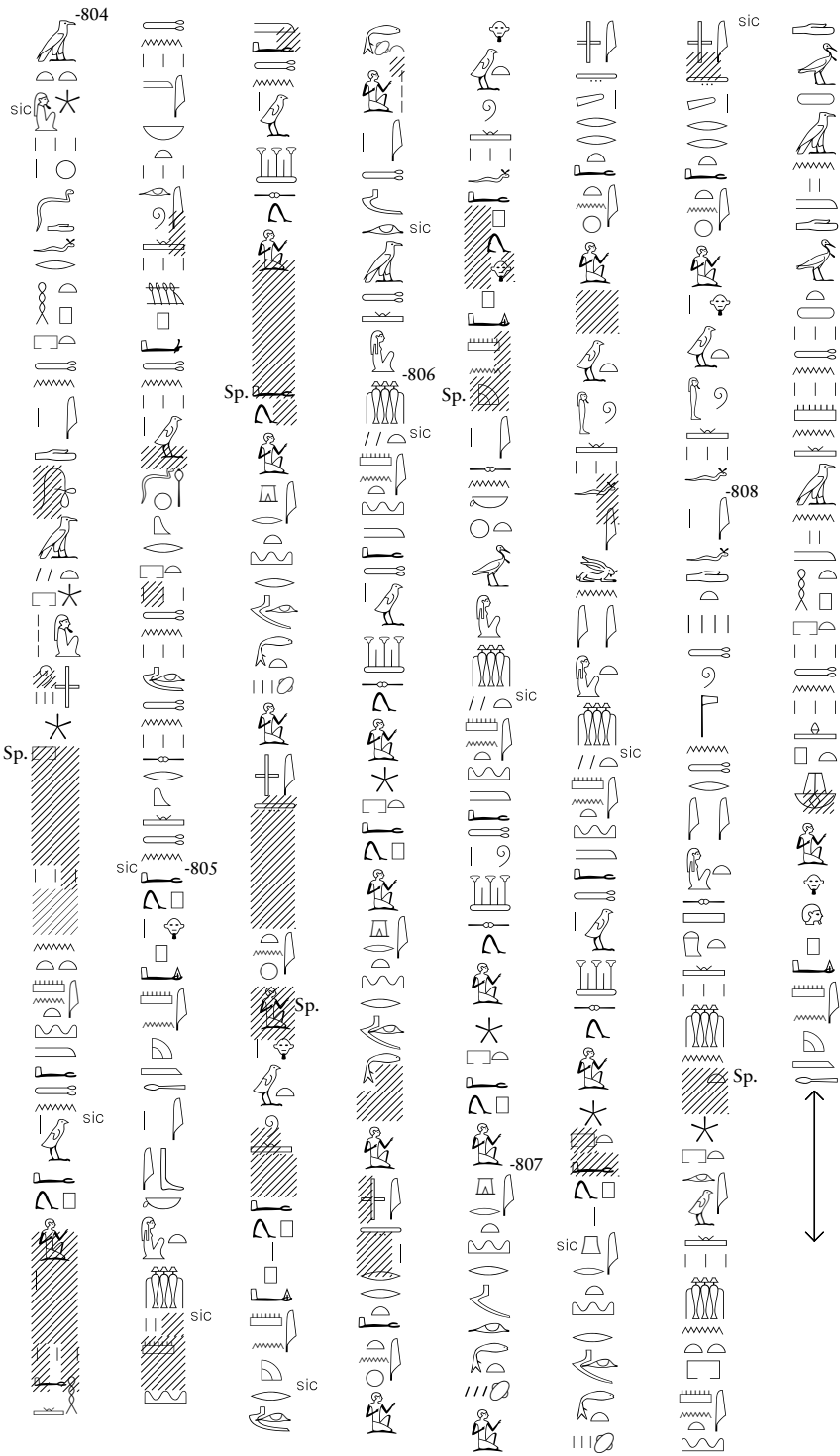

Hb. 79.36-59 (DOI 10.17171/2-8-150)

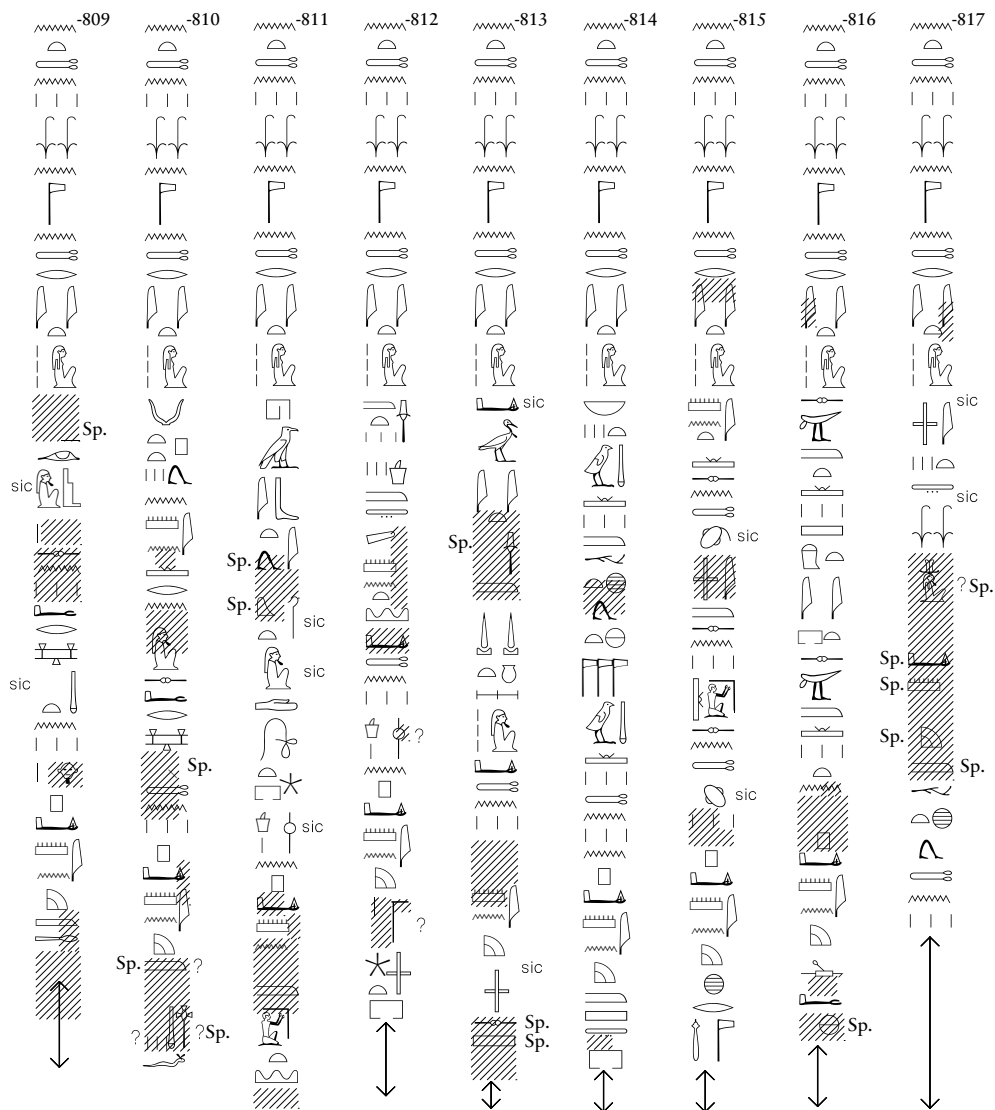

Hb. 79.60-67
(DOI 10.17171/2-8-150)

Hb. 80.1-30
(DOI 10.17171/2-8-151)

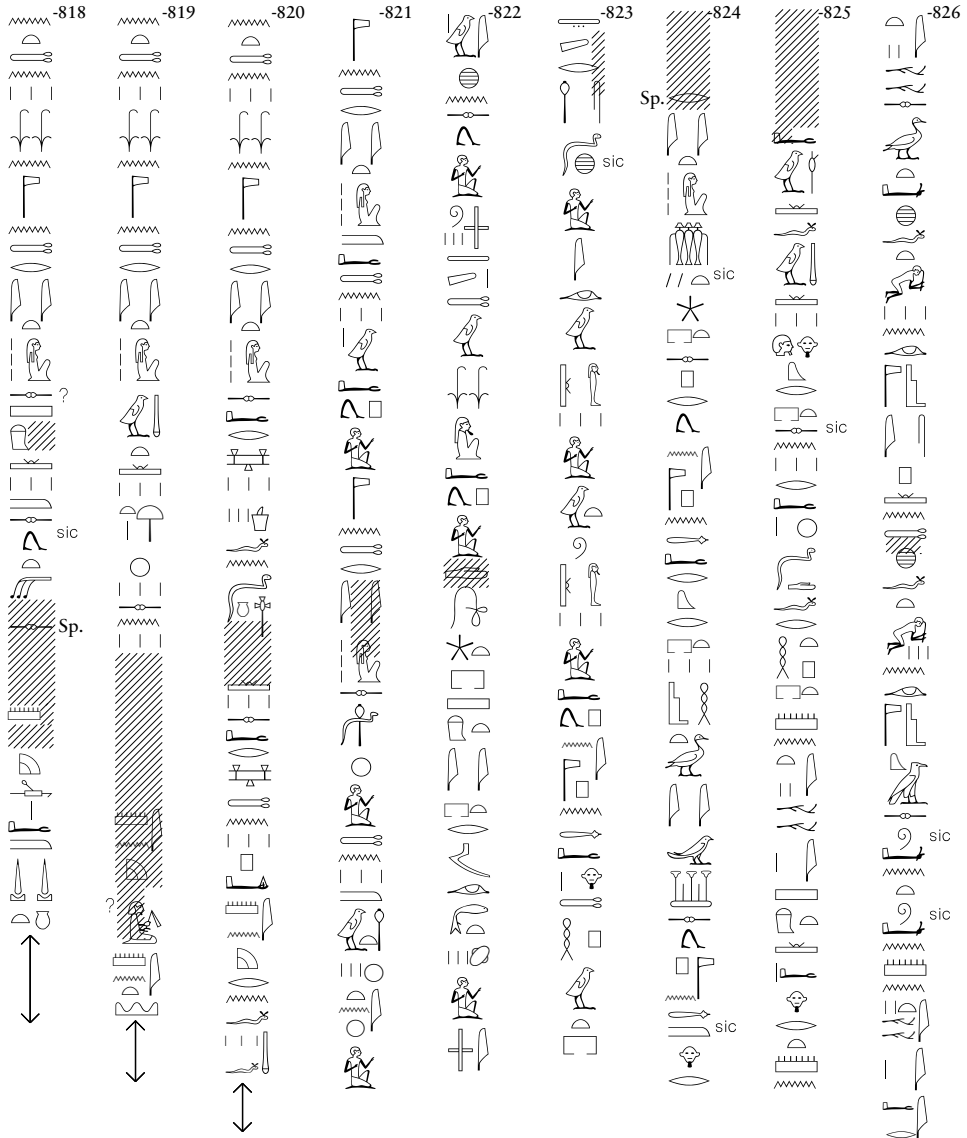



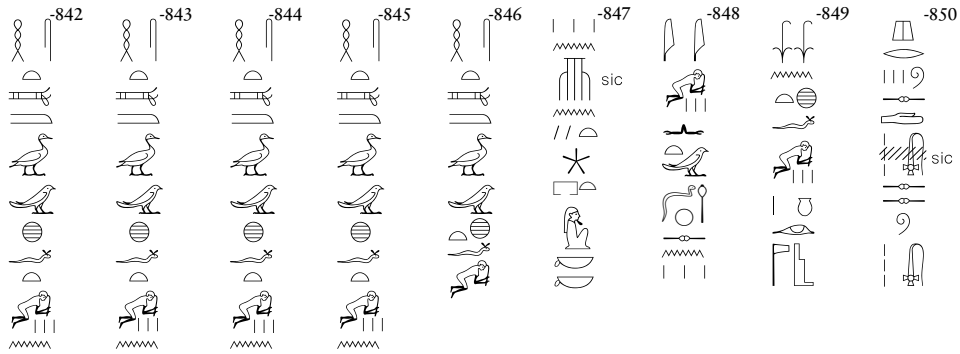

Hb. 80.62-69
(DOI 10.17171/2-8-151)

Hb. 81.1-17
(DOI 10.17171/2-8-152)

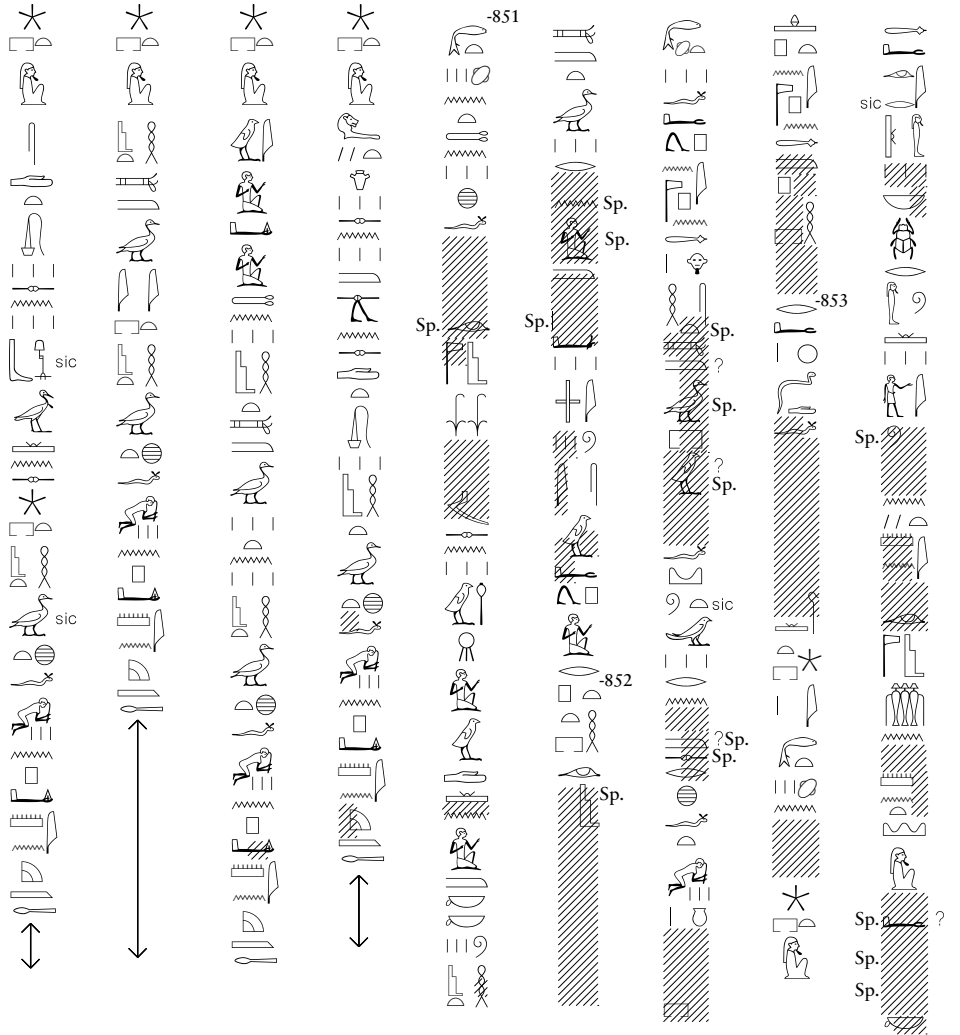

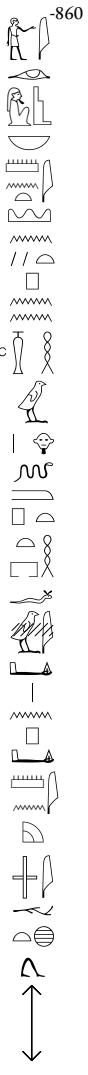
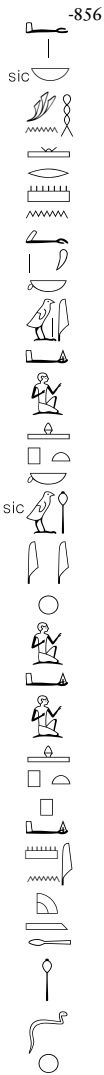
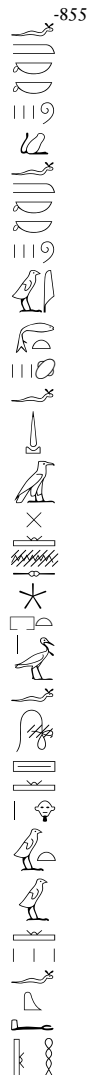

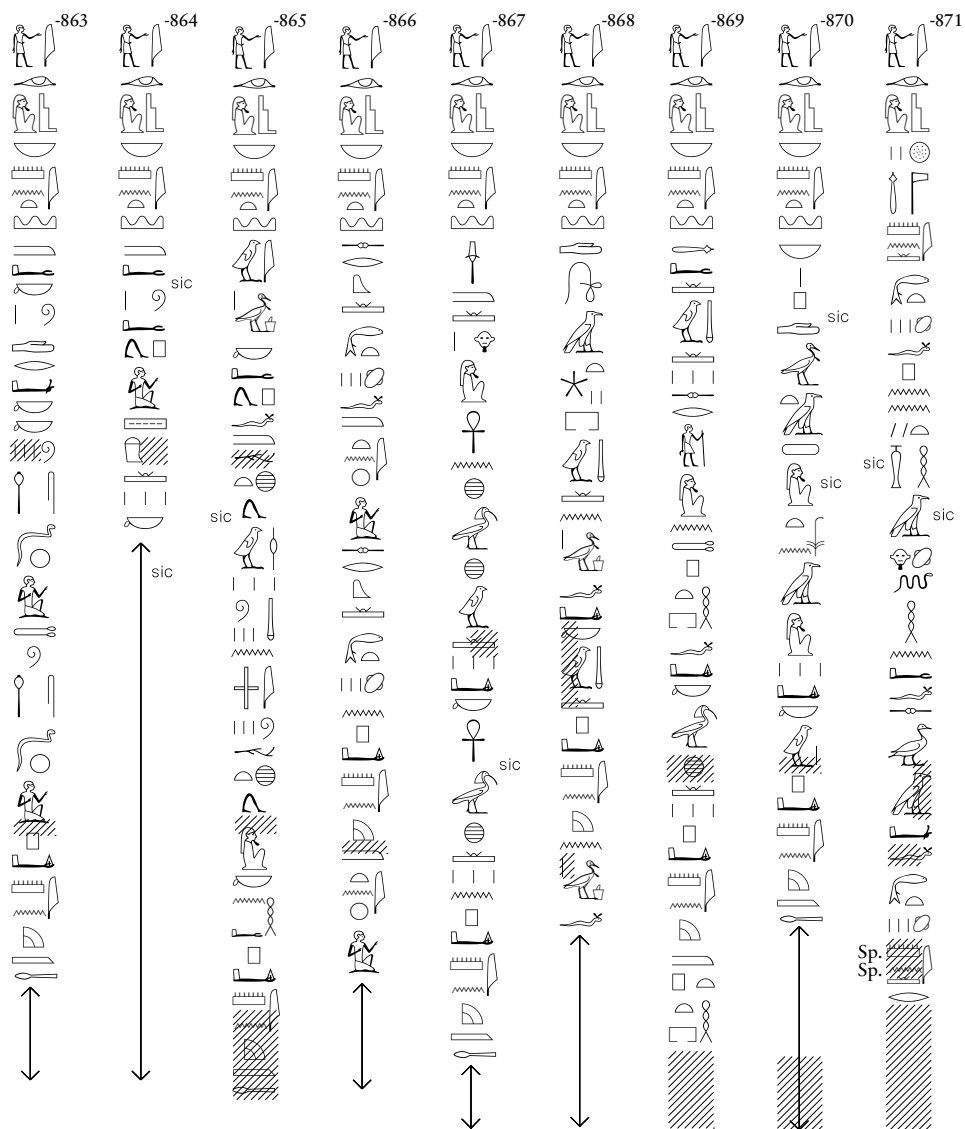

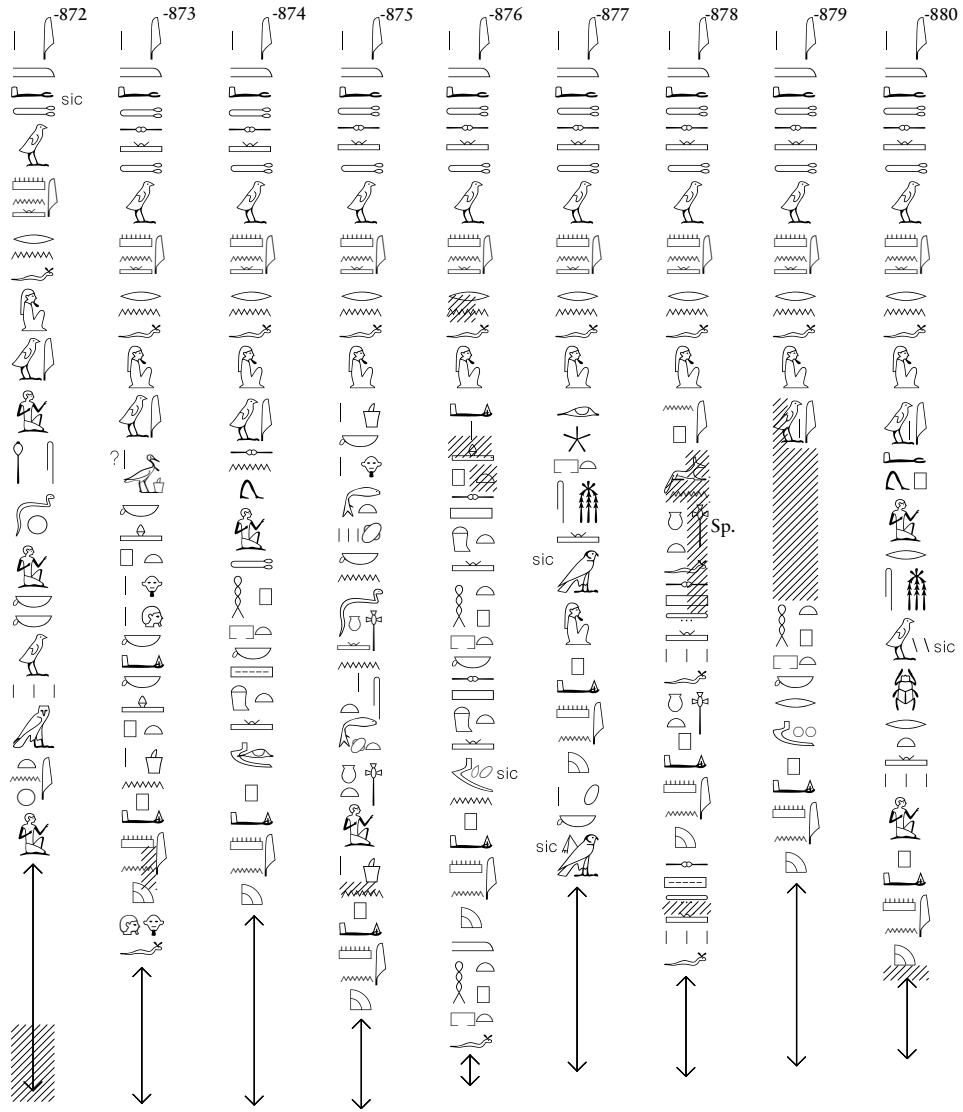

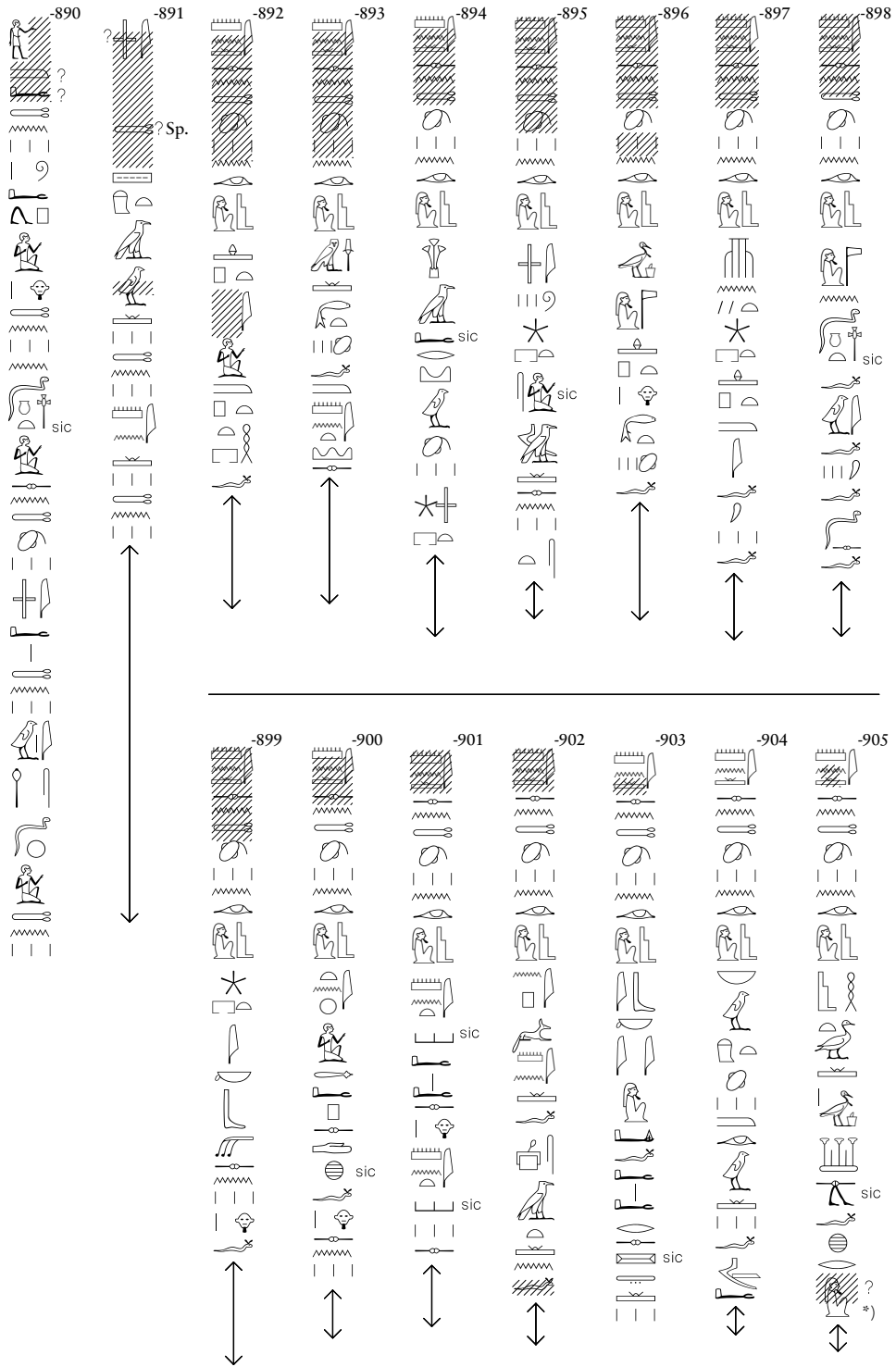

*) Eine sitzende Figur.

Hb. 82.39-49 (DOI 10.17171/2-8-153)

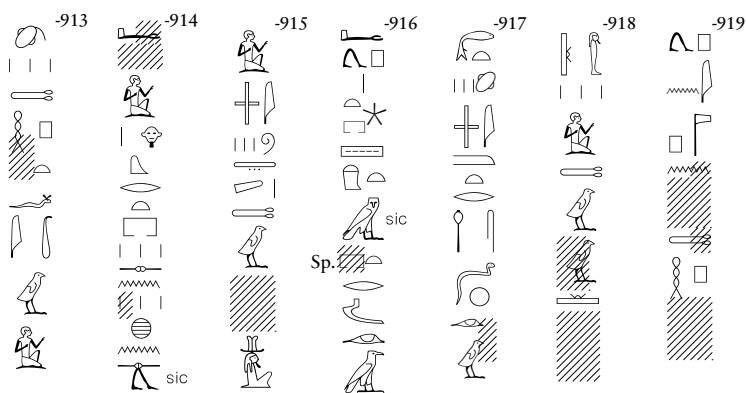
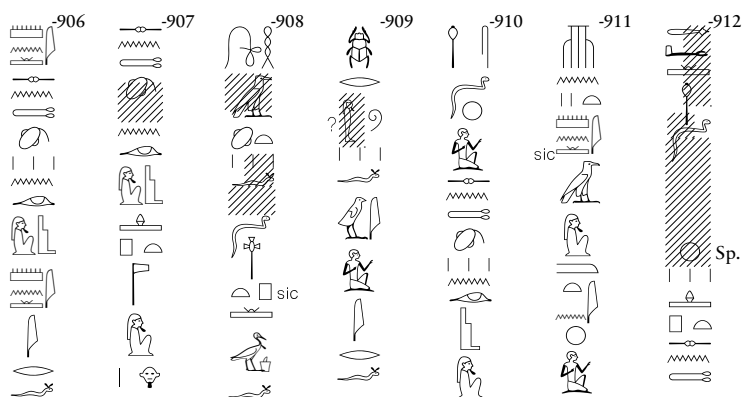

-920 sic

-921 sic

-922 Sp.

-923 sic

-924

-925 sic

-926 sic

-927 sic

-928 sic

*) Oder Gott ohne Bart: 

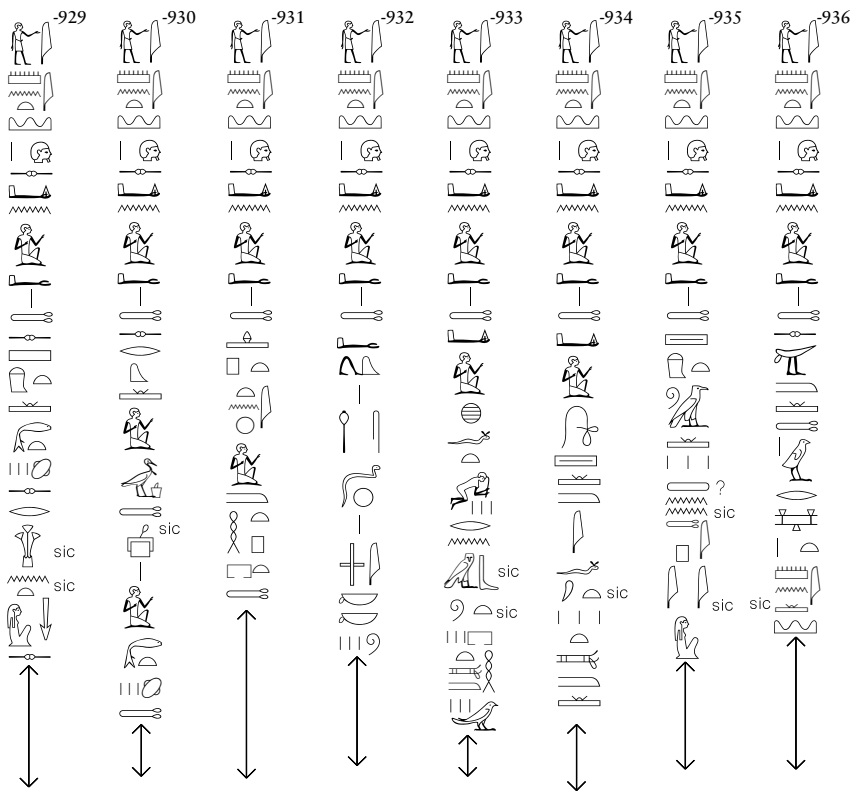

Hb. 83.39-56 (DOI 10.17171/2-8-154)

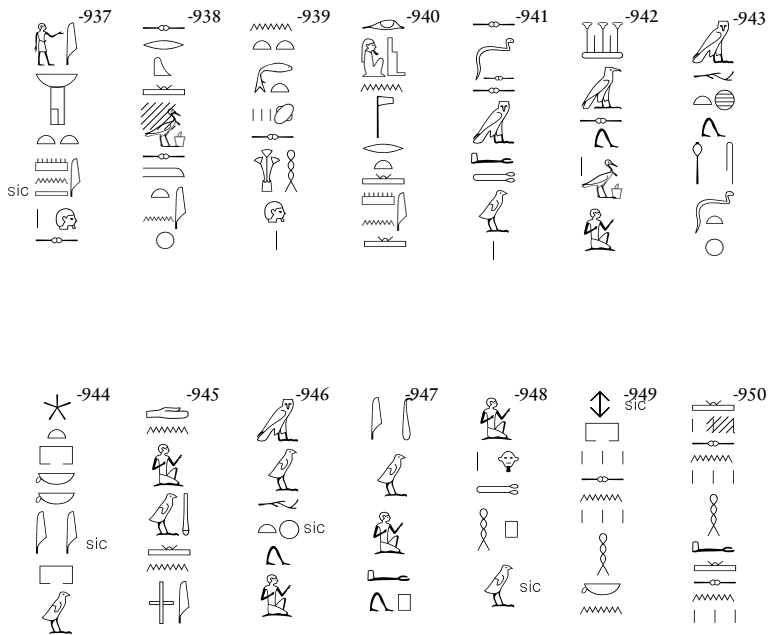

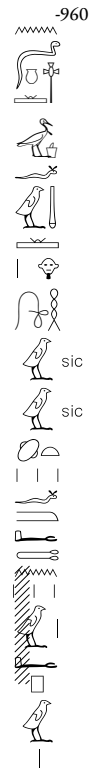
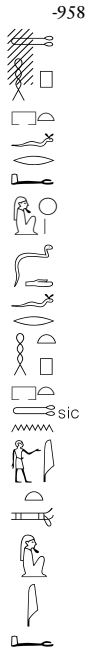
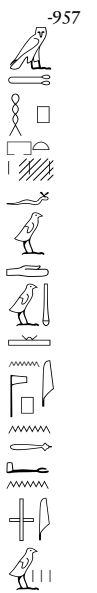
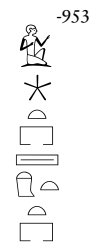
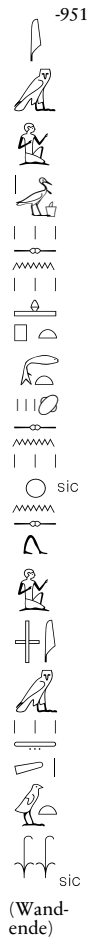

Hb. 84.21-44
 (DOI 10.17171/2-8-155)

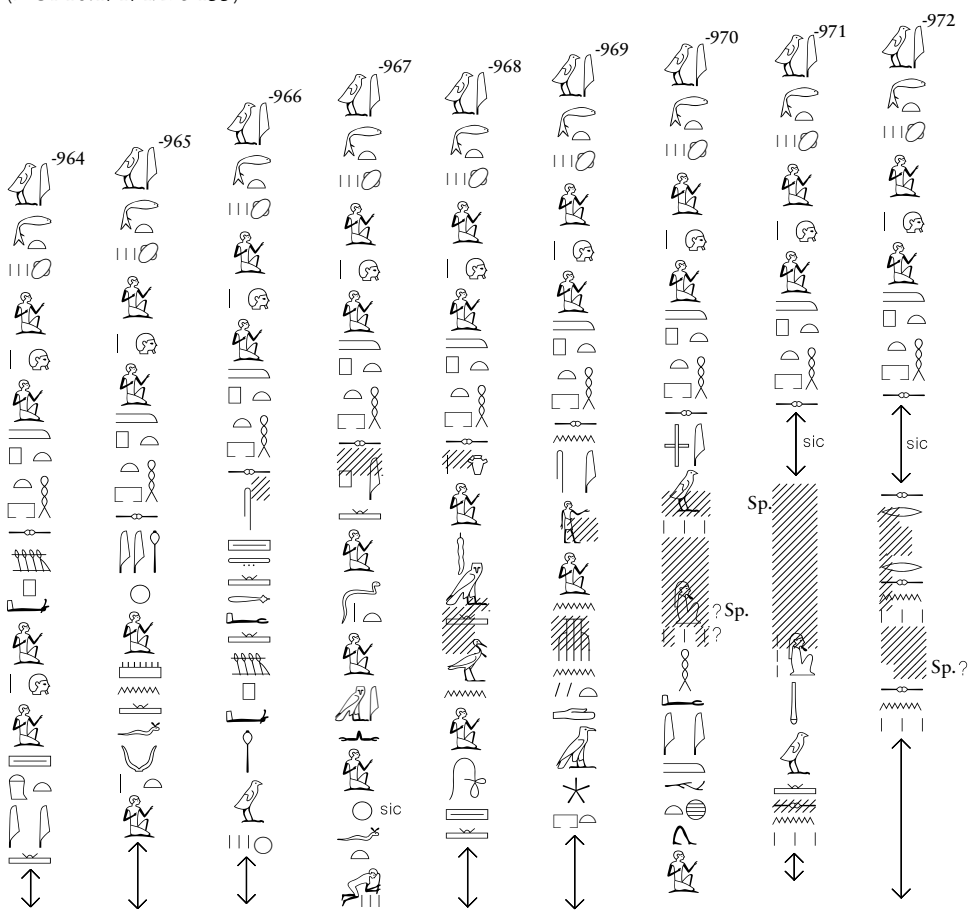

Hb. 85.1-17
(DOI 10.17171/2-8-156)

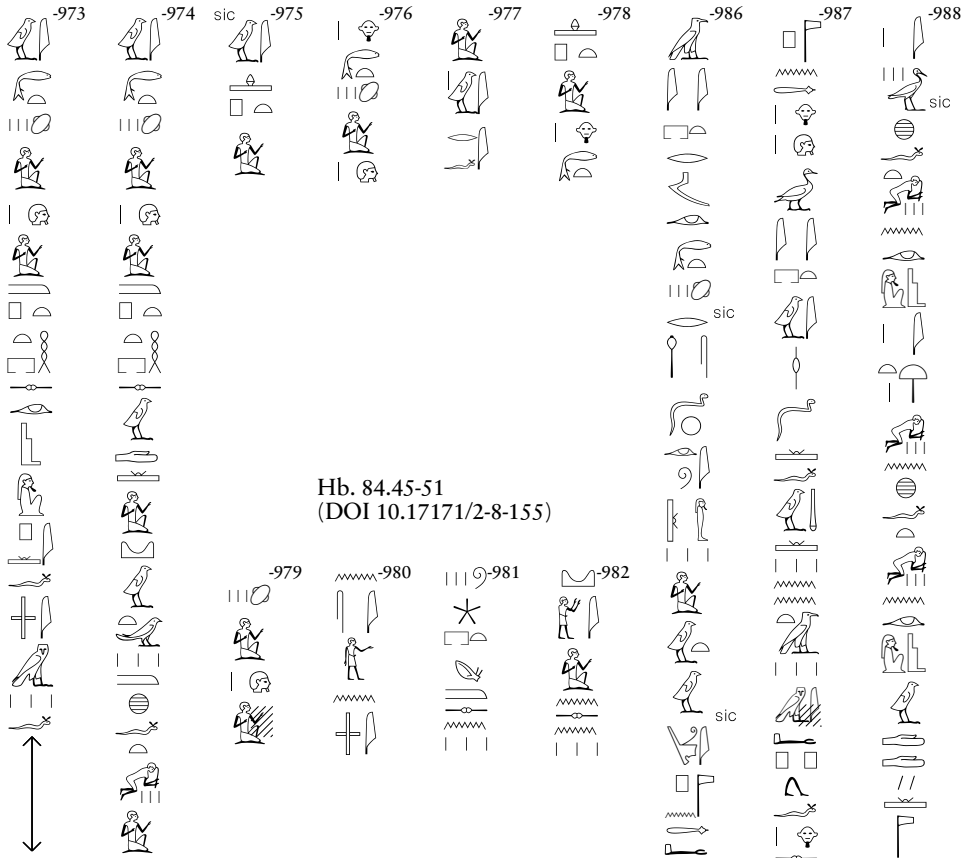

Hb. 84.45-51
(DOI 10.17171/2-8-155)

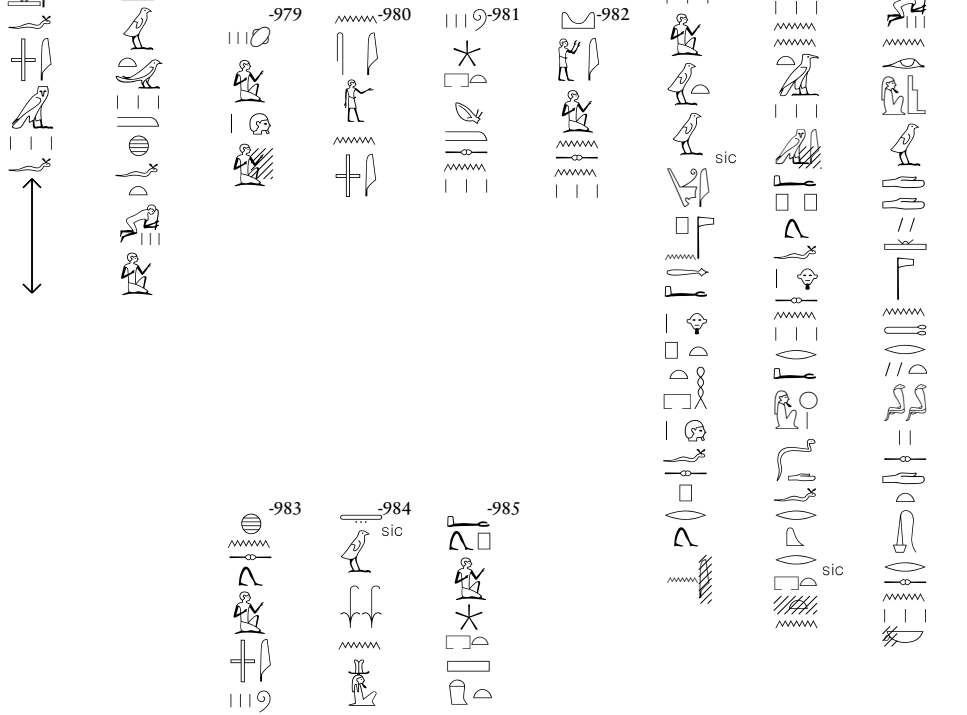

Hb. 85.18-52
(DOI 10.17171/2-8-156)



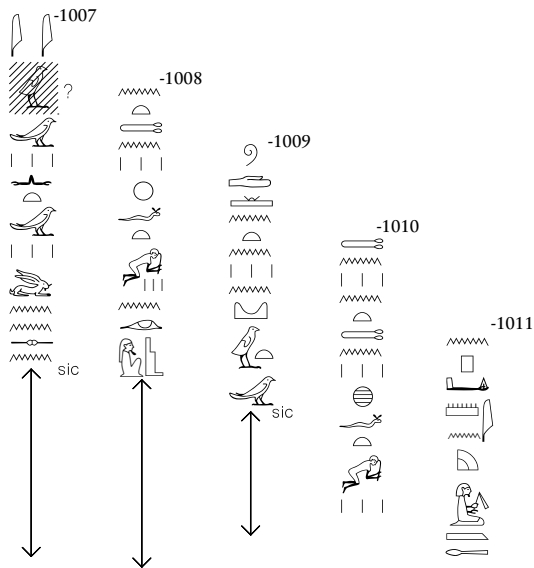
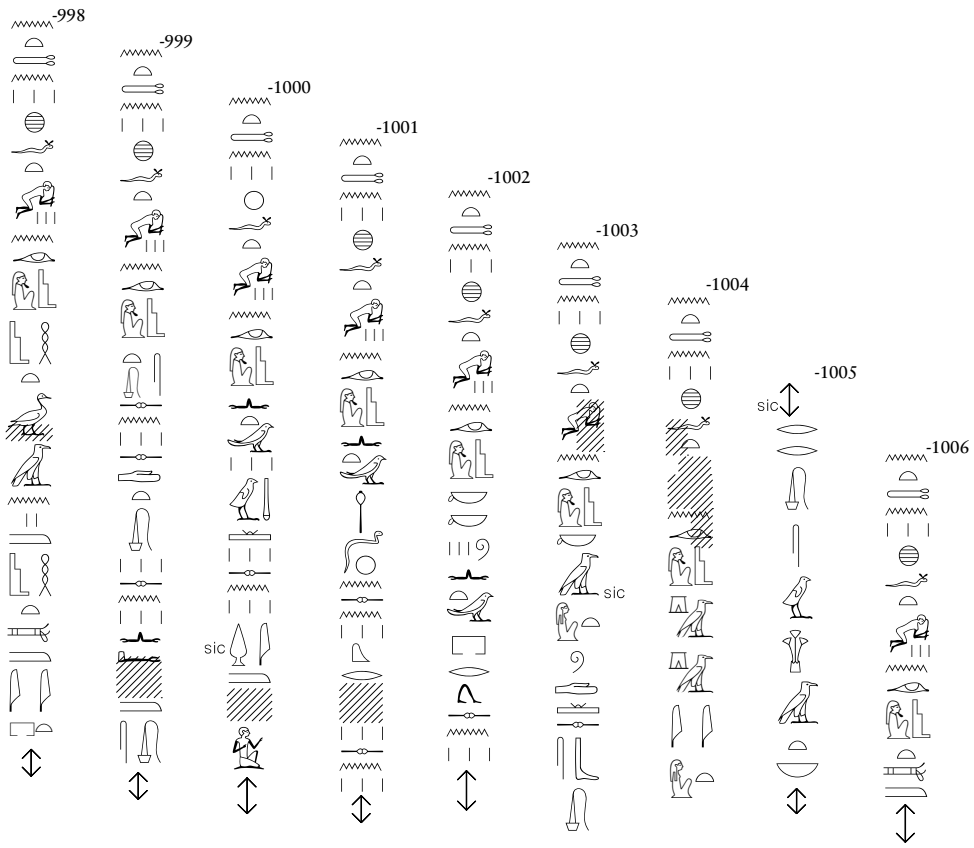

Hb. 85.53-60 (DOI 10.17171/2-8-156)

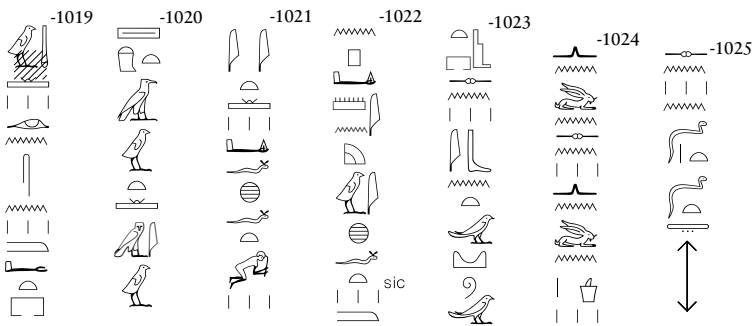
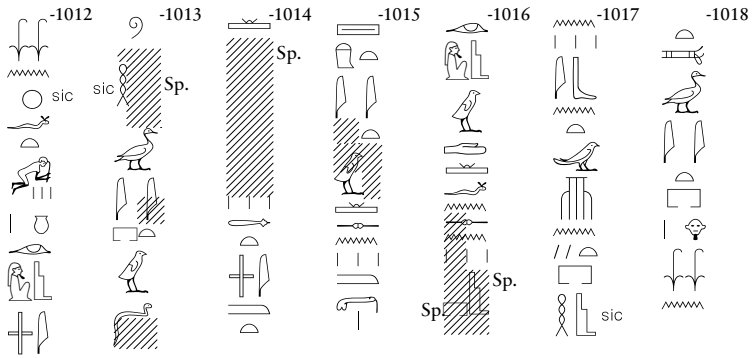

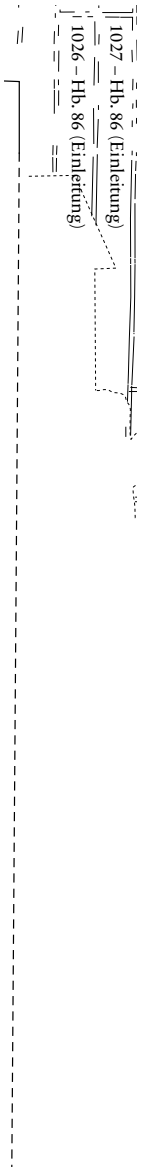

Hb. 86 (DOI 10.17171/2-8-157)

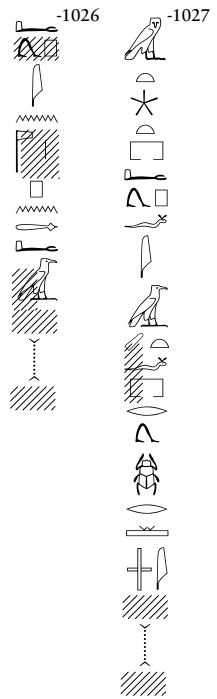

1041 - Hb. 87	
1040 - Hb. 87	
1039 - Hb. 87	
1038 - Hb. 87	
1037 - Hb. 87	
1036 - Hb. 87	
1035 - Hb. 87	
1034 - Hb. 87, 411 (W)	
1033 - Hb. 87	
1032 - Hb. 87	
1031 - Hb. 87, 22, 29 (C)	
1028 - Hb. 87, 12, 21 (R)	
1029 - Hb. 87	
1030 - Hb. 87	

Sz. LXIV

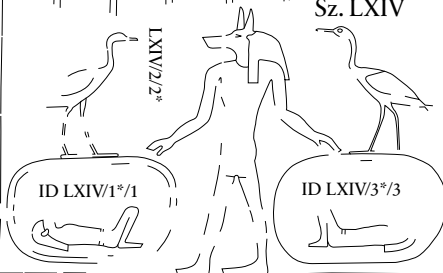

Hb. 87.12-21 (DOI 10.17171/2-8-158)

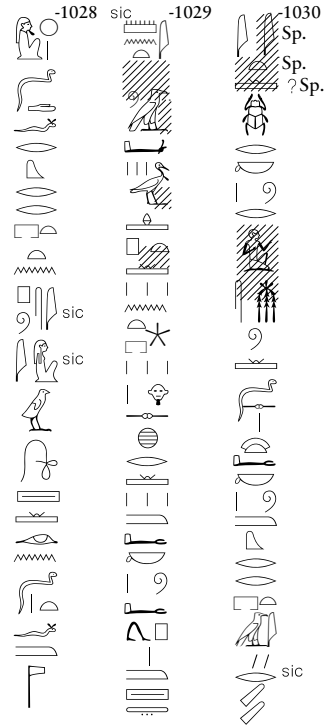

Hb. 87.12-21 (DOI 10.17171/2-8-158)

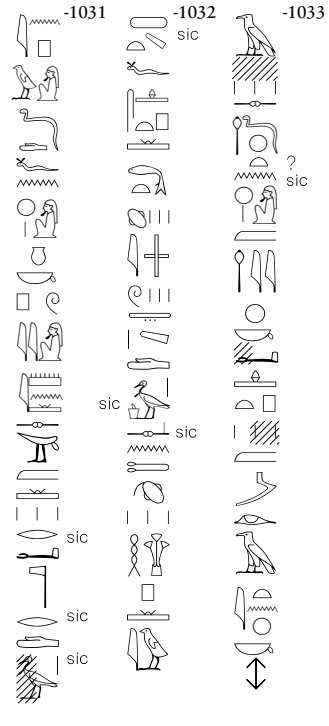

Hb. Sz. LXIV (DOI 10.17171/2-8-57)

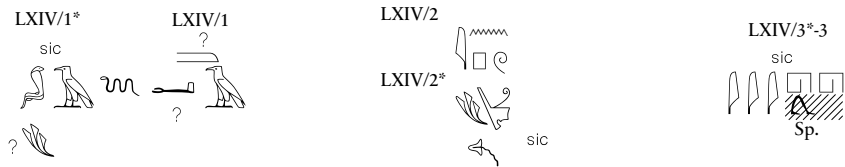

Hb. 87.4-11 (DOI 10.17171/2-8-158)

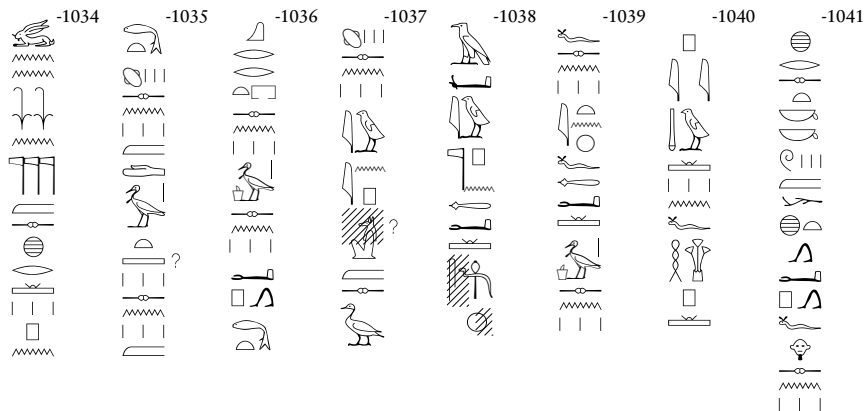

1056 – Hb. 88

[1055] – Hb. 88

1054 – Hb. 88

1053 – Hb. 88

1052 – Hb. 88

1051 – Hb. 88

1050 – Hb. 88

1049 – Hb. 88

1048 – Hb. 88, 7-15 (W)

1047 – Hb. 88

1046 – Hb. 88

1045 – Hb. 88, 23-32 (C)

1042 – Hb. 88, 16-22 (R)

1043 – Hb. 88

1044 – Hb. 88

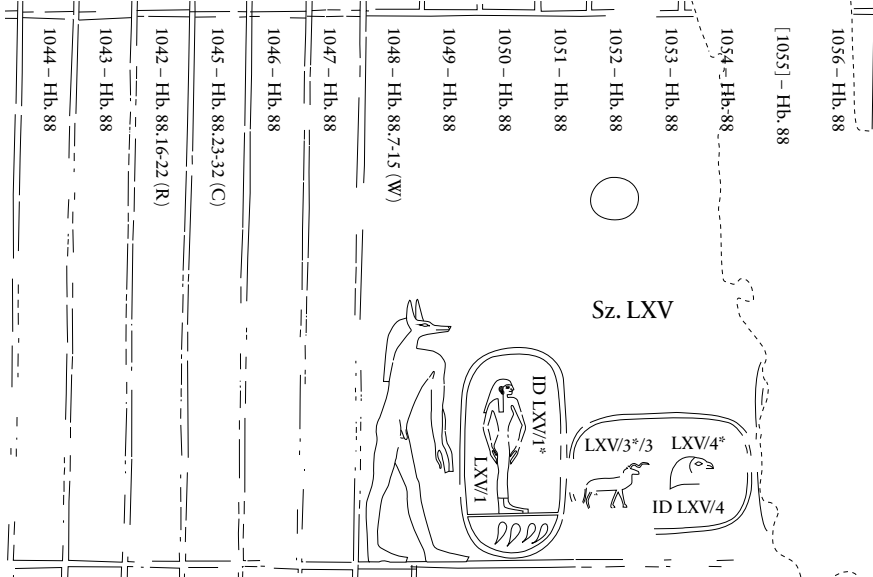

Hb. 88.16-22
(DOI 10.17171/2-8-159)



Hb. 88.23-32
(DOI 10.17171/2-8-159)



Hb. Sz. LXV
(DOI 10.17171/2-8-58)

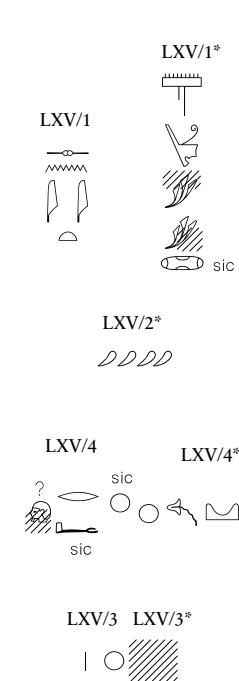

Hb. 88.7-15 (DOI 10.17171/2-8-159)

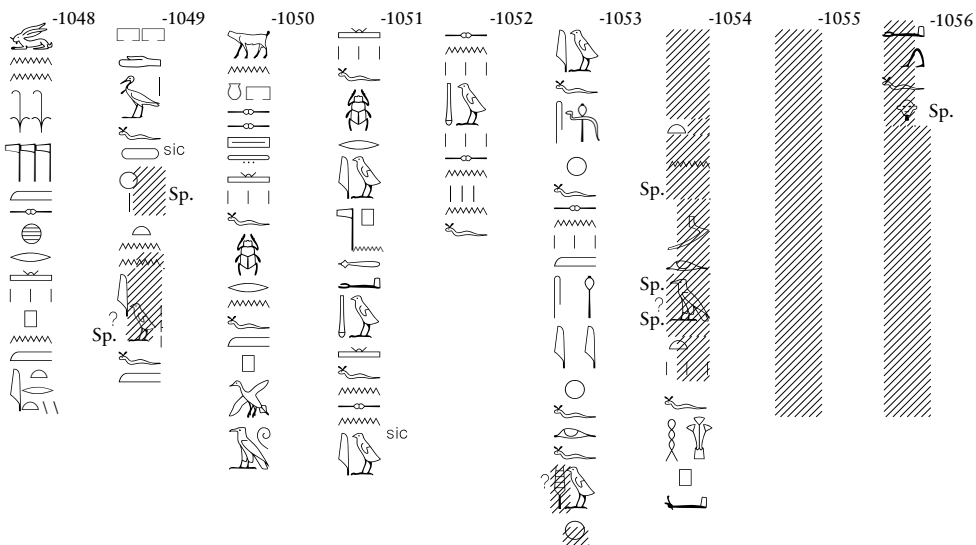

1073 - Hb. 90	
1069 - Hb. 89	
1068 - Hb. 89	
1067 - Hb. 89	Sz. LXVI
1066 - Hb. 89	
1065 - Hb. 89	
1064 - Hb. 89	
1063 - Hb. 89.5-12 (W)	
1062 - Hb. 89	
1061 - Hb. 89	
1060 - Hb. 89.21-31 (C)	
1057 - Hb. 89.13-20 (R)	
1058 - Hb. 89	
1059 - Hb. 89	

Hb. 89.13-20
(DOI 10.17171/2-8-160)

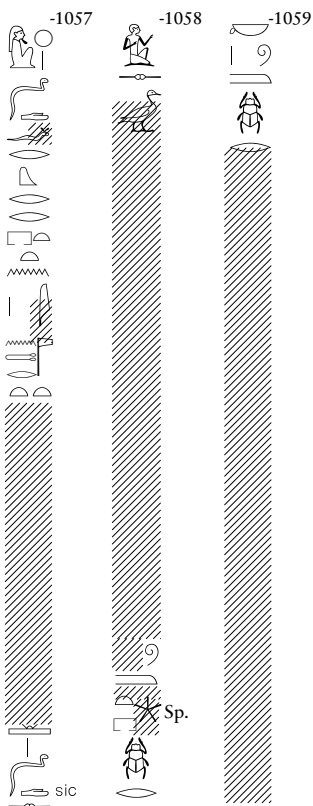

Hb. 89.21-31
(DOI 10.17171/2-8-160)

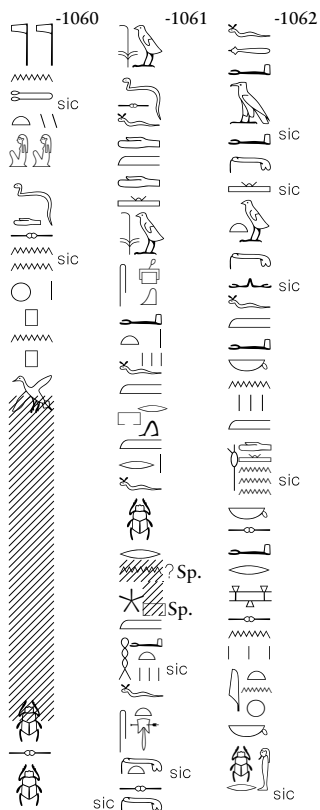

Hb. Sz. LXVI (DOI 10.17171/2-8-59)

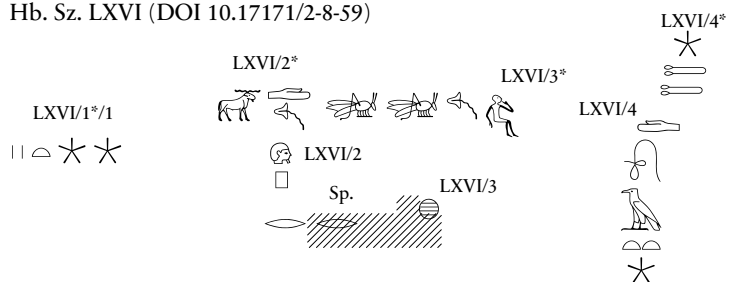

Hb. 89.5-12 (DOI 10.17171/2-8-160)

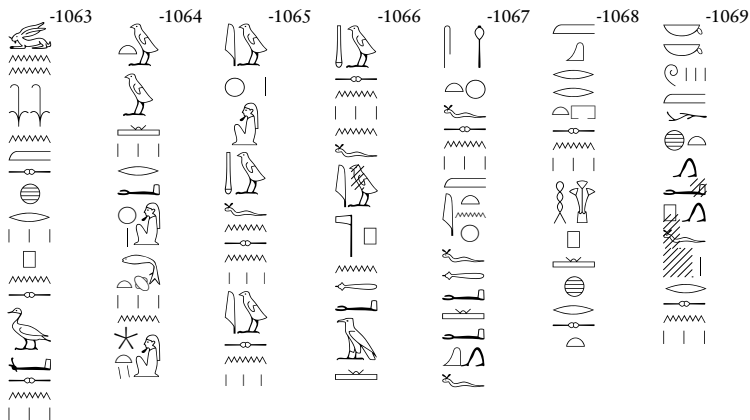

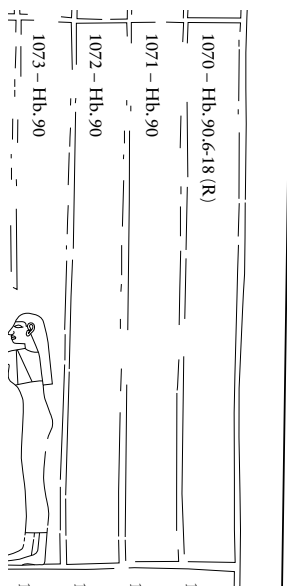

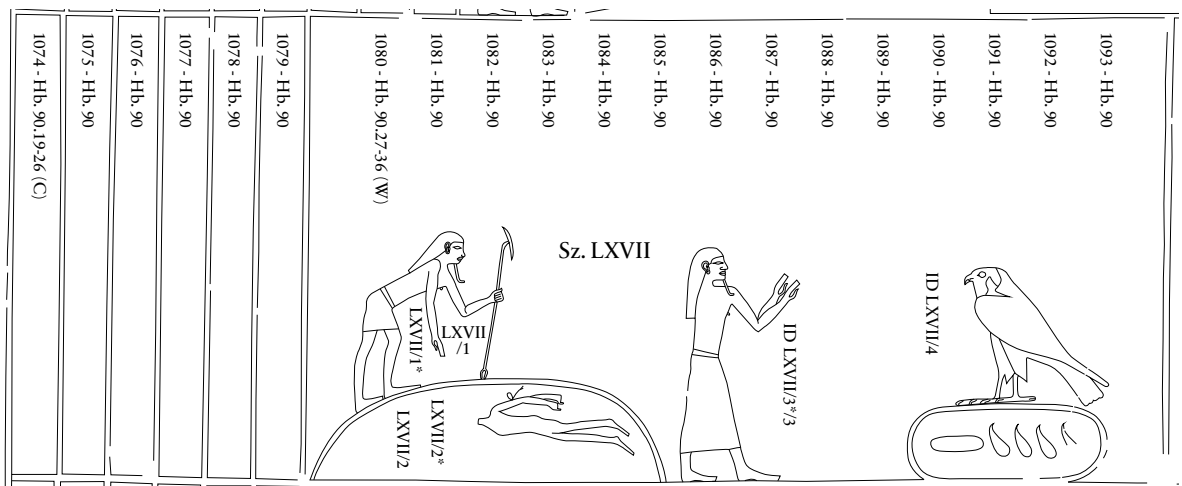

1101 - Hb. 90
1100 - Hb. 90
1099 - Hb. 90
1098 - Hb. 90
1097 - Hb. 90
1096 - Hb. 90
1095 - Hb. 90
1094 - Hb. 90, 37-51 (C)
1093 - Hb. 90
1092 - Hb. 90
1091 - Hb. 90
1090 - Hb. 90

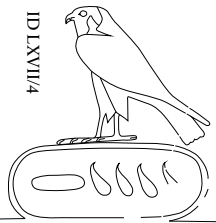

ID LXVII/4

Hb. 90.6-18 (DOI 10.17171/2-8-161)

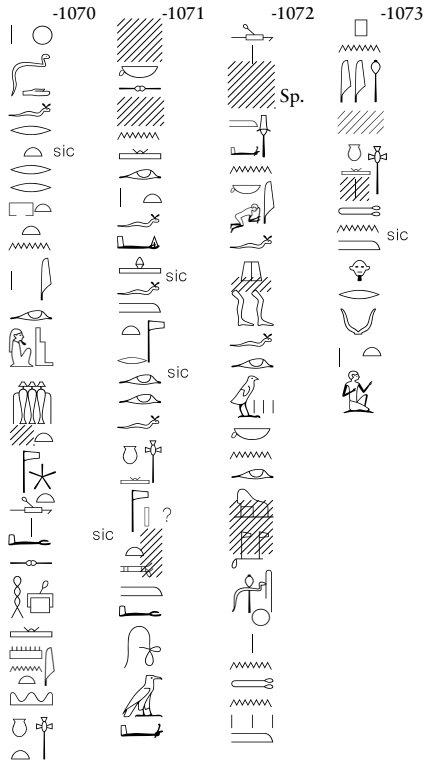

Hb. 90.19-26 (DOI 10.17171/2-8-161)

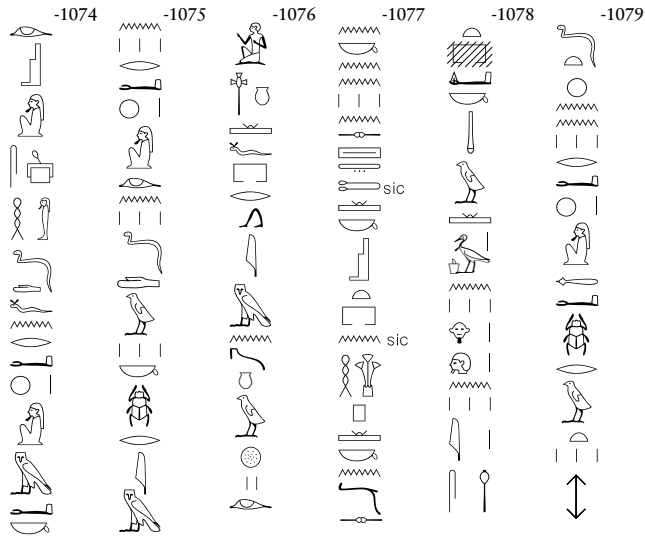

Hb. Sz. LXVII
(DOI 10.17171/2-8-60)

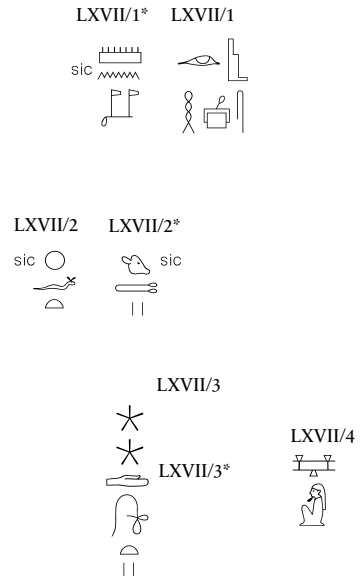

Hb. 90.27-36 (DOI 10.17171/2-8-161)

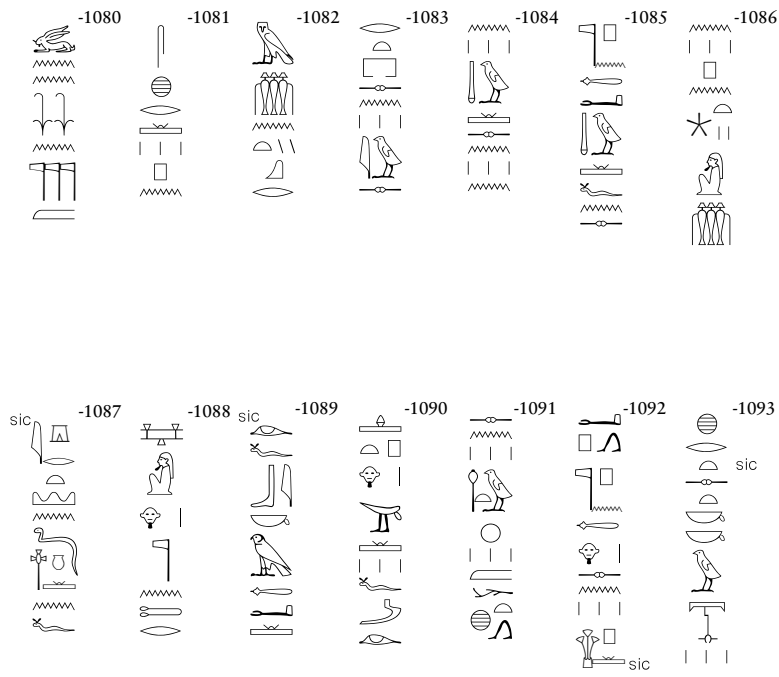

Hb. 90.37-51 (DOI 10.17171/2-8-161)

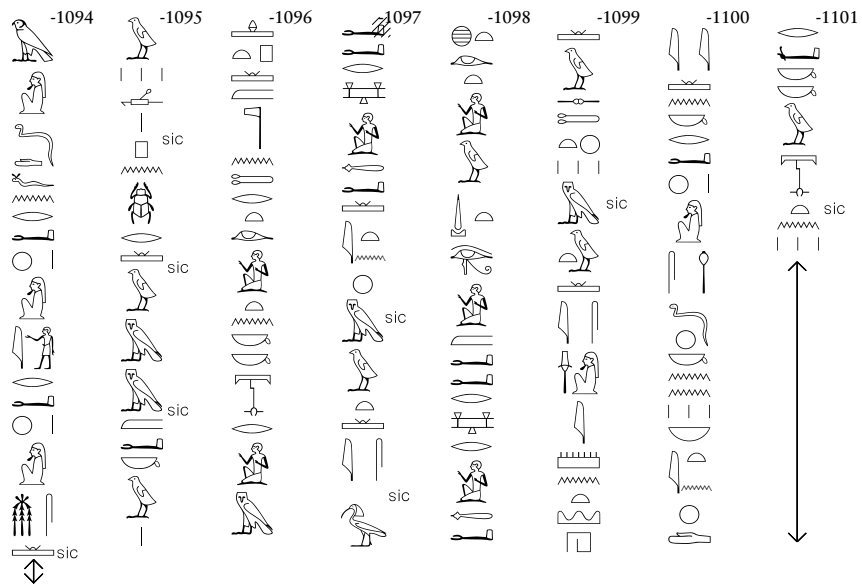

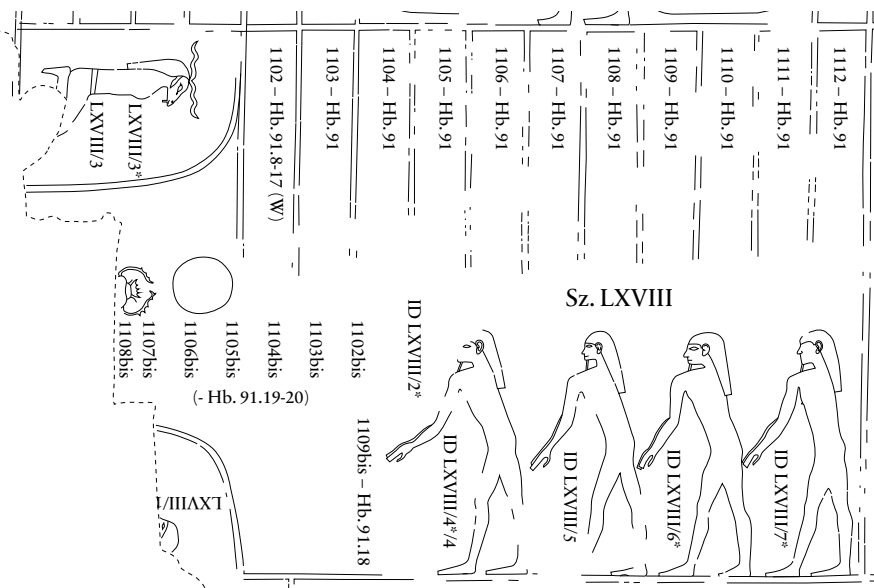

Hb. Sz. LXVIII (DOI 10.17171/2-8-162)

LXVIII/3



Hb. 91.18-20 (DOI 10.17171/2-8-162)

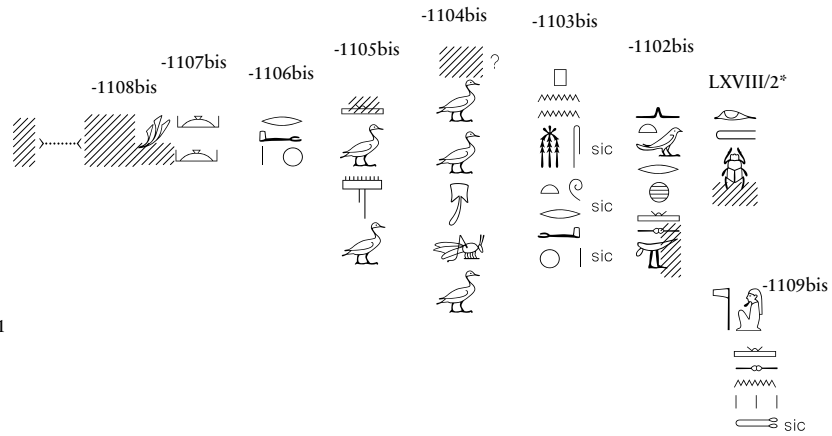

Hb. 91.8-17 (DOI 10.17171/2-8-162)

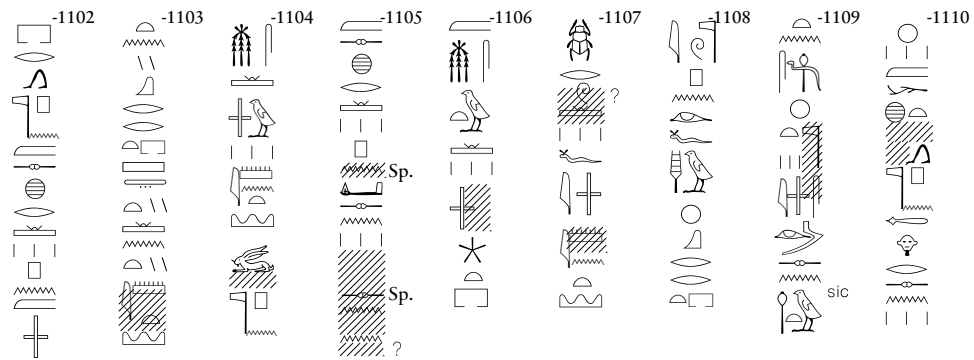

Hb. Sz. LXVIII (DOI 10.17171/2-8-162)

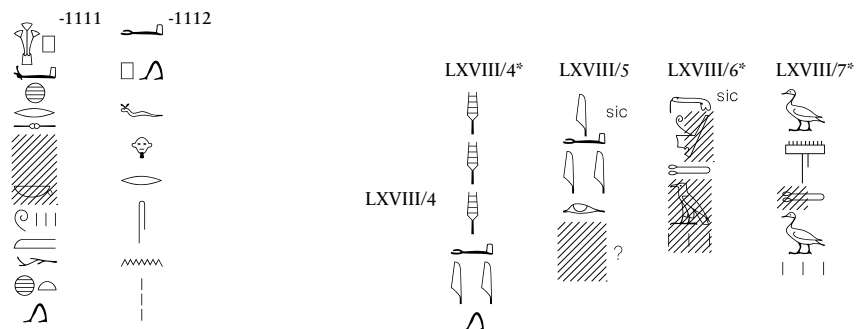

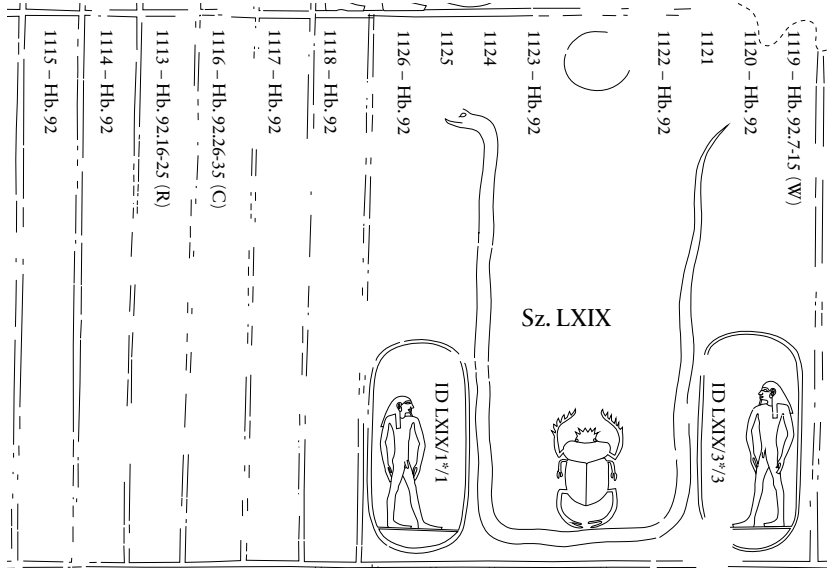

Hb. 92.16-25
(DOI 10.17171/2-8-163)

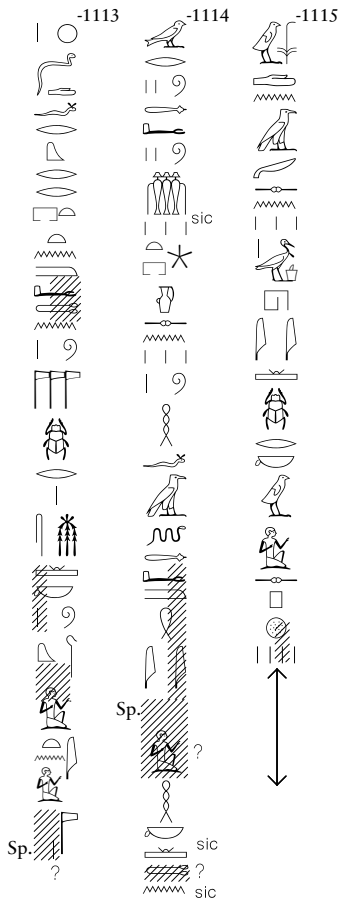

Hb. 92.26-35
(DOI 10.17171/2-8-163)



Hb. Sz. LXIX
(DOI 10.17171/2-8-62)

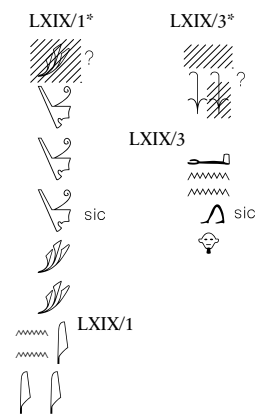

Hb. 92.7-15 (DOI 10.17171/2-8-62)

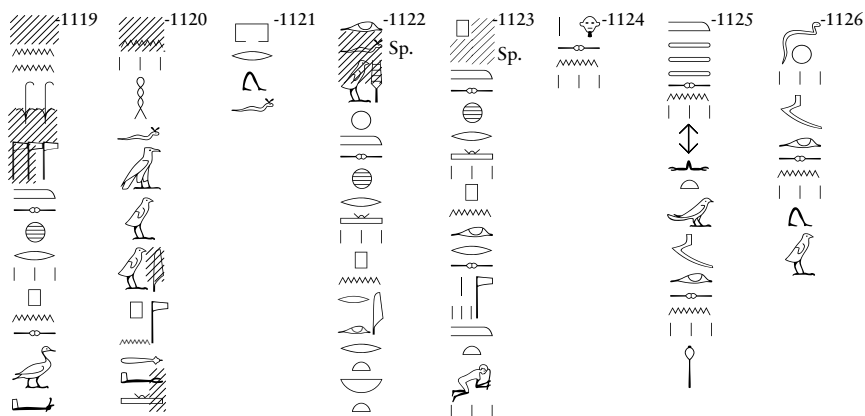

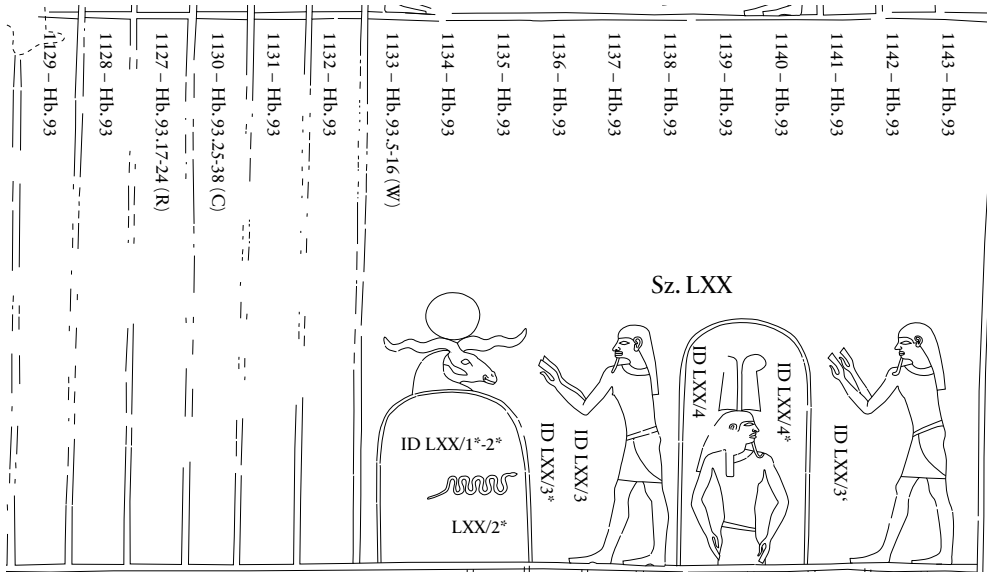

Hb. 93.17-24
(DOI 10.17171/2-8-164)

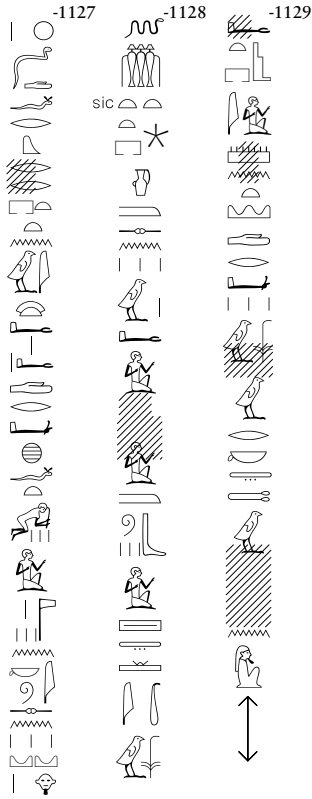

Hb. 93.25-38
(DOI 10.17171/2-8-164)

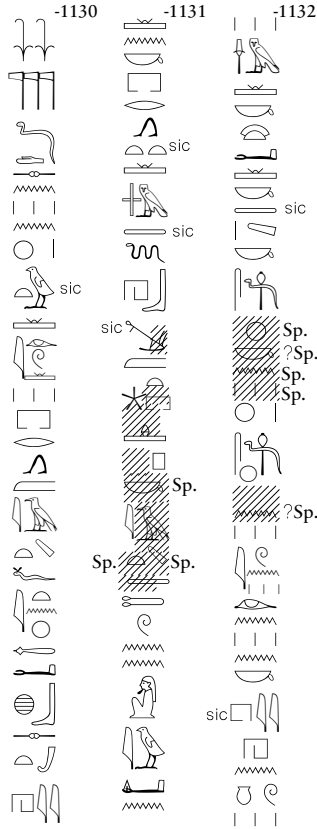

Hb. Sz. LXX (DOI 10.17171/2-8-63)

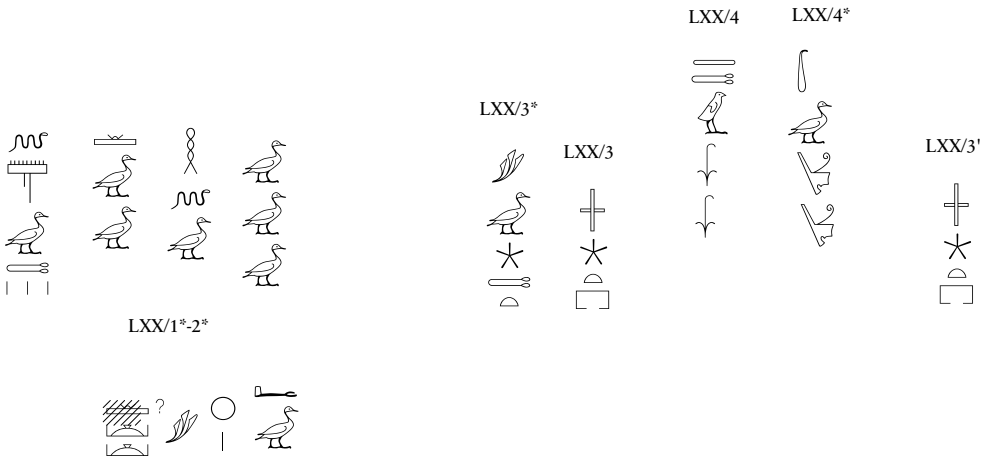

1160 - Hb, 94	<p>Sz. LXXI</p>
1159 - Hb, 94	
1158 - Hb, 94	
1157 - Hb, 94	
1156 - Hb, 94	
1155 - Hb, 94	
1154 - Hb, 94, 2, 7 (W)	
1153 - Hb, 94	
1152 - Hb, 94	
1151 - Hb, 94	
1150 - Hb, 94, 18, 30 (C)	
1144 - Hb, 94, 8, 17 (R)	
1145 - Hb, 94	
1146 - Hb, 94	
1147 - Hb, 94	
1148 - Hb, 94	
1149 - Hb, 94	

1170 -Hb. 95	
1169 -Hb. 95	
1168 -Hb. 95,5-10 (W)	
1161 -Hb. 95,11-24 (R)	
1162 -Hb. 95	
1163 -Hb. 95	
1164 -Hb. 95	
1165 -Hb. 95	
1166 -Hb. 95	
1167 -Hb. 95	

Hb. 95.11-24 (DOI 10.17171/2-8-166)

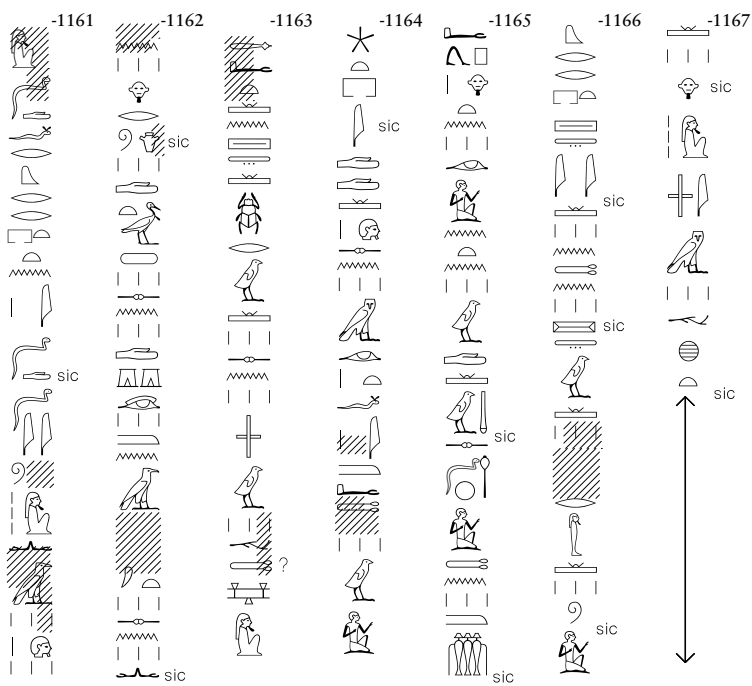

Hb. 95.5-10
(DOI 10.17171/2-8-166)

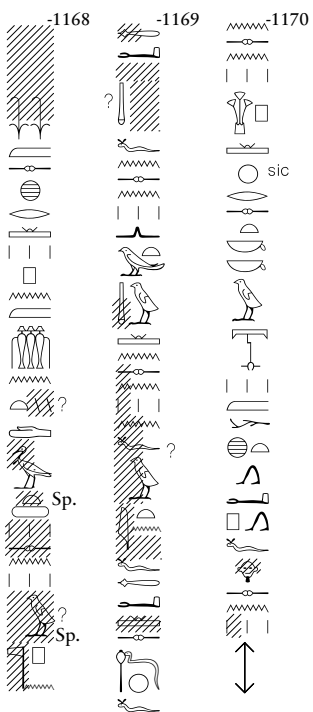

Hb. Sz. LXXII (DOI 10.17171/2-8-65)

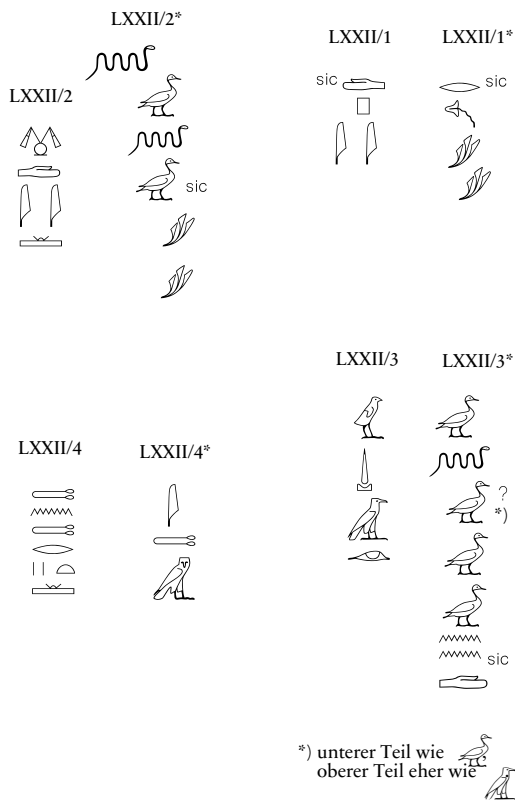

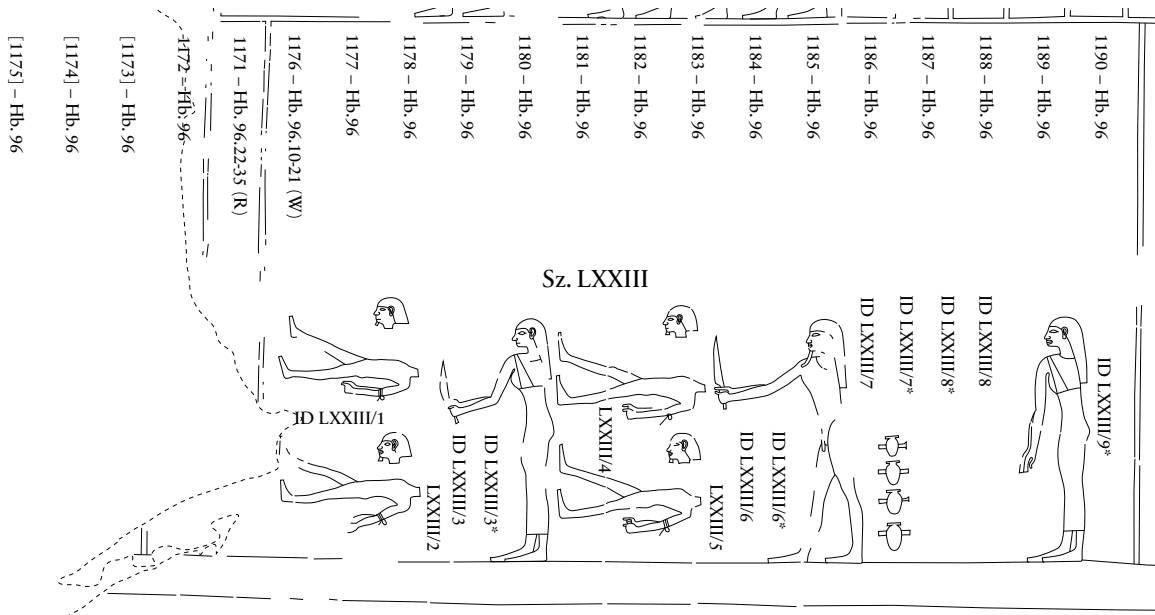

Hb. 96.22-35 (DOI 10.17171/2-8-167)

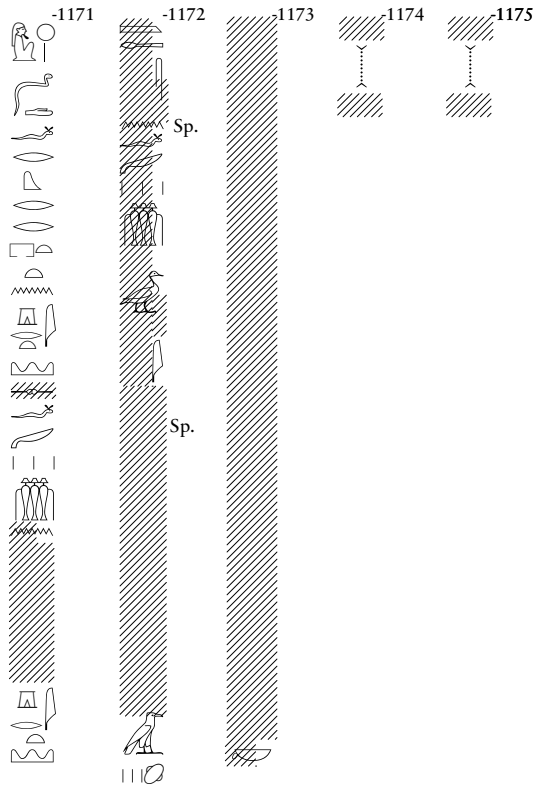

Hb. 96.10-21 (DOI 10.17171/2-8-66)

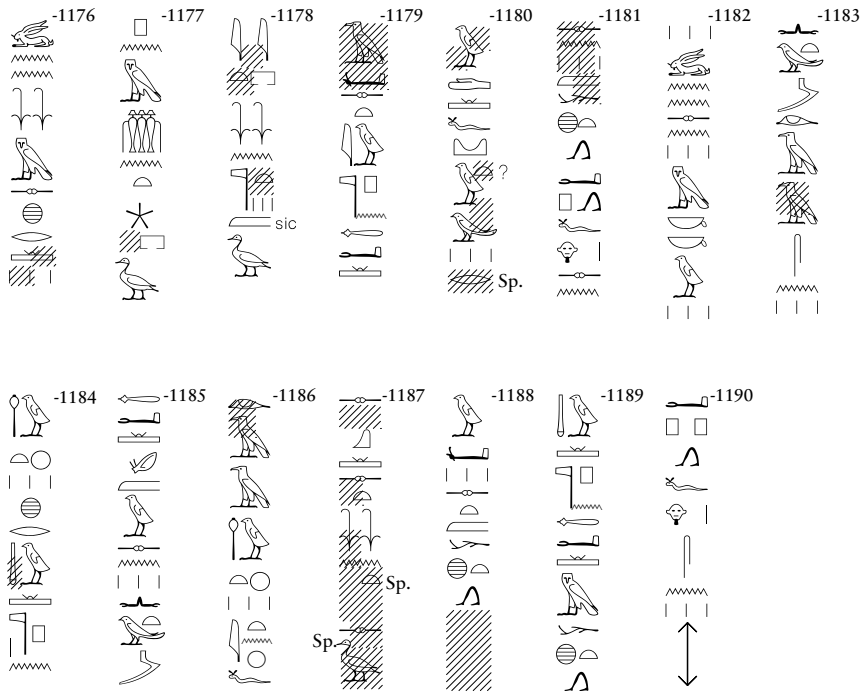

Hb. Sz. LXXIII (DOI 10.17171/2-8-66)

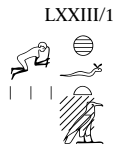

LXXIII/3

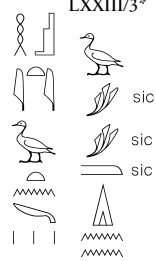

LXXIII/4



LXXIII/6



LXXIII/2



LXXIII/5

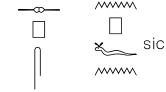

LXXIII/7



LXXIII/7*



LXXIII/8*



LXXIII/8



LXXIII/9*



1206 – Hb. 97	
1205 – Hb. 97	
1204 – Hb. 97	
1203 – Hb. 97	
1202 – Hb. 97	
1201 – Hb. 97	
1200 – Hb. 97	
1199 – Hb. 97	
1198 – Hb. 97	
1197 – Hb. 97	
1196 – Hb. 97.7-14 (W)	
1191 – Hb. 97.15-29 (R)	
1192 – Hb. 97	
1193 – Hb. 97	
1194 – Hb. 97	
1195 – Hb. 97	

Sz. LXXIV

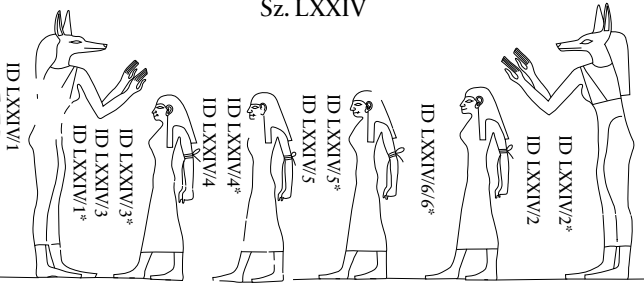

Hb. 97.15-29 (DOI 10.17171/2-8-168)

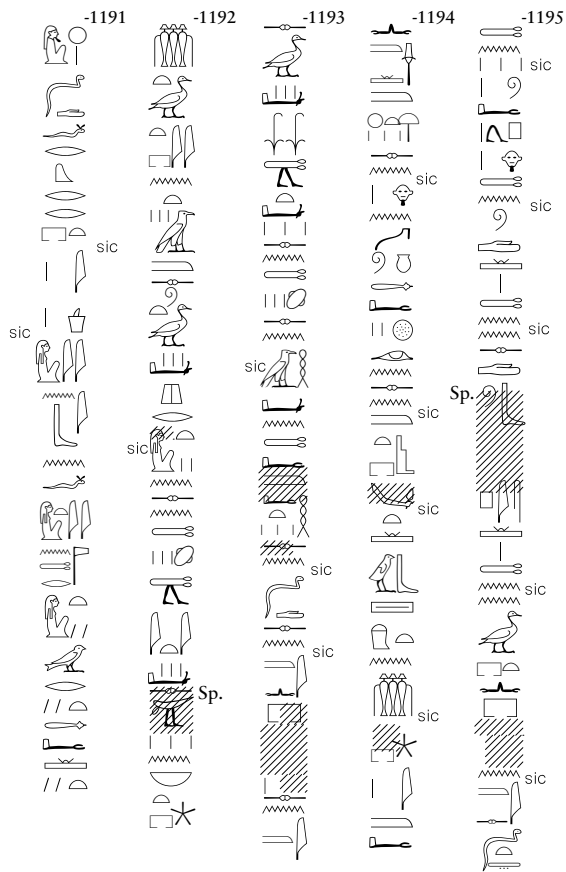

Hb. 97.7-14 (DOI 10.17171/2-8-67)

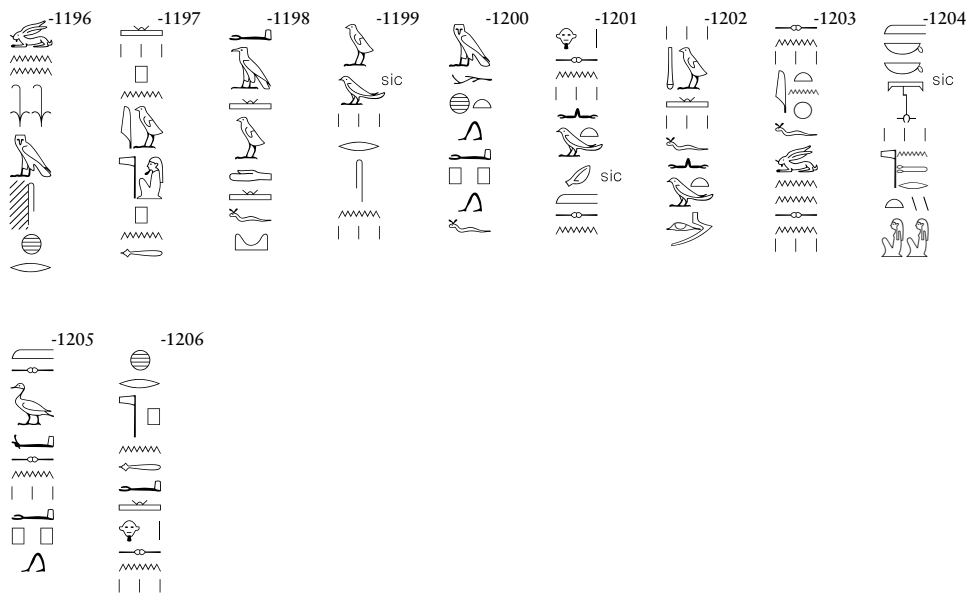

LXXIV/1



LXXIV/1*



LXXIV/3



LXXIV/3*



LXXIV/4



LXXIV/4*



LXXIV/5



LXXIV/5*



LXXIV/6/6*



LXXIV/2



LXXIV/2*



1207 - Hb. 98.11-21 (R)
1208 - Hb. 98
1209 - Hb. 98
1210 - Hb. 98
1211 - Hb. 98
1212 - Hb. 98
1213 - Hb. 98
1214 - Hb. 98
1215 - Hb. 98

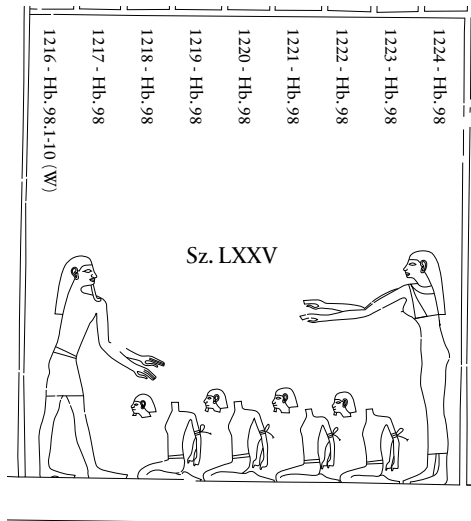

Hb. 98.11-21 (DOI 10.17171/2-8-169)

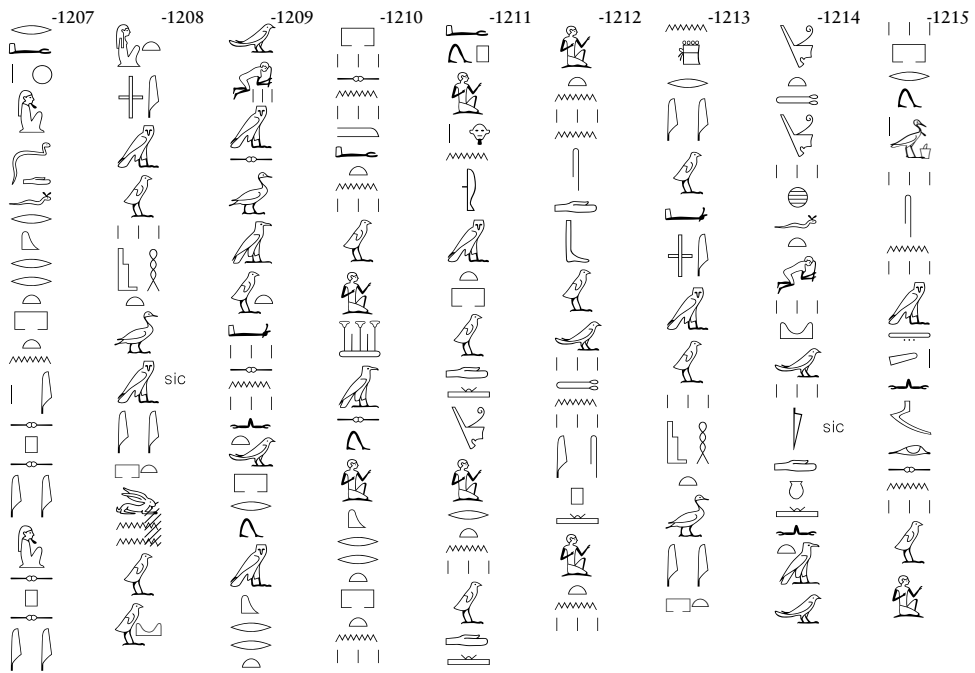

Hb. 98.1-10 (DOI 10.17171/2-8-68)

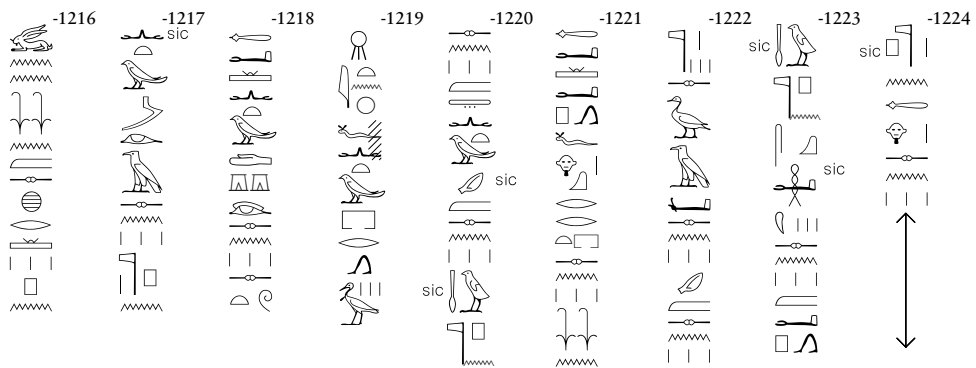

1238 - Hb. 99	ID LXXXVI/1	ID LXXXVII/2*
1237 - Hb. 99	ID LXXXVI/1	ID LXXXVII/2
1236 - Hb. 99	ID LXXXVI/1*	ID LXXXVII/1*
1235 - Hb. 99		
1234 - Hb. 99		
1233 - Hb. 99		
1232 - Hb. 99,4.10 (W)		
1225 - Hb. 99,11-22 (R)		
1226 - Hb. 99		
1227 - Hb. 99		
1228 - Hb. 99		
1229 - Hb. 99		
1230 - Hb. 99		
1231 - Hb. 99		

Sz. LXXXVI

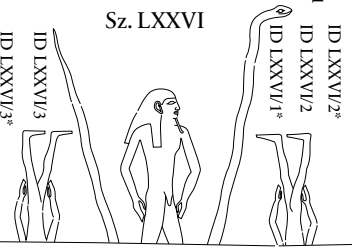

Hb. 99.11-22 (DOI 10.17171/2-8-170)

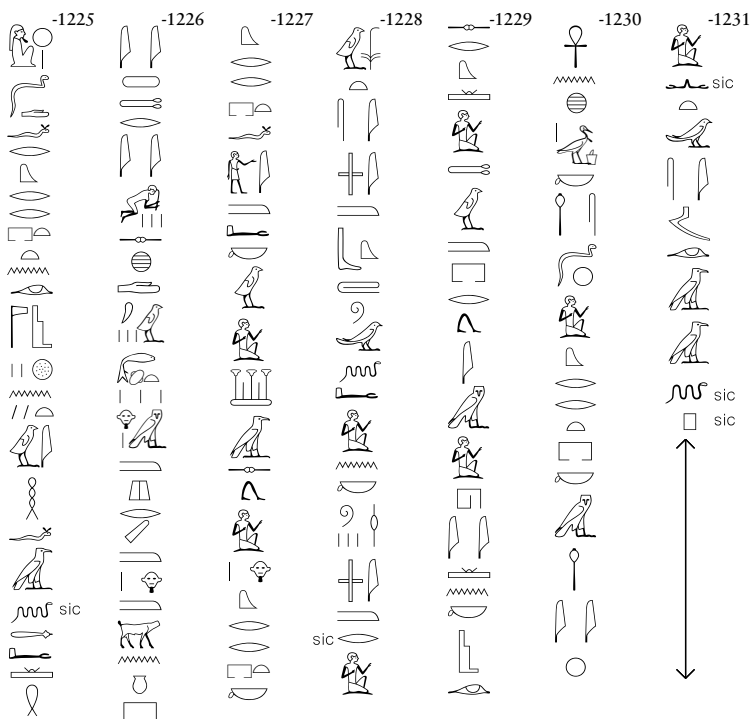

Hb. 99.4-10 (DOI 10.17171/2-8-69)

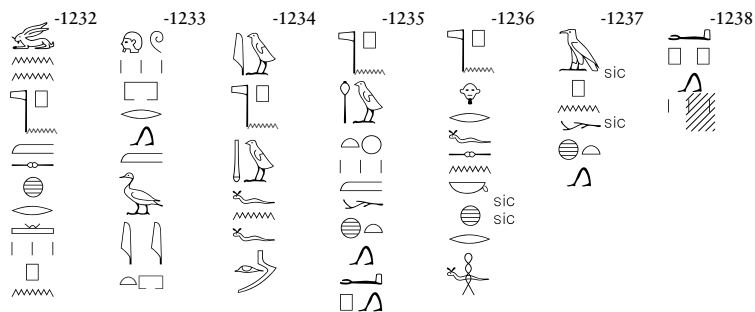

Hb. Sz. LXXVI (DOI 10.17171/2-8-69)

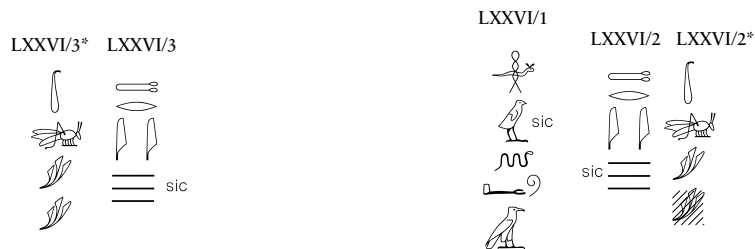

1239 - Hb, 100,1-9 (R)
1240 - Hb, 100
1241 - Hb, 100
1242 - Hb, 100
1243 - Hb, 100
1244 - Hb, 100
1245 - Hb, 100
1246 - Hb, 100

Hb. 100 (DOI 10.17171/2-8-171)

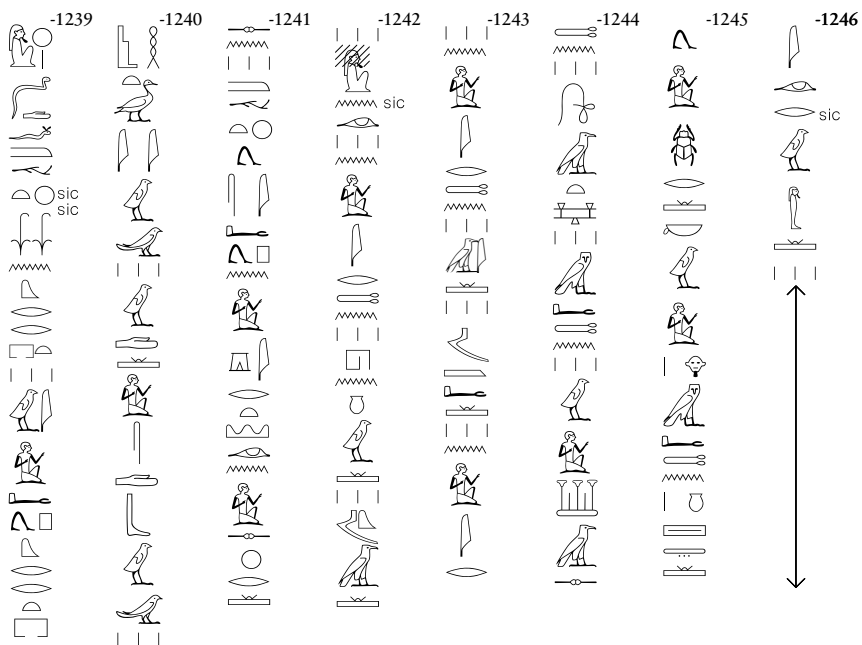

sic

1265 - Hb. 101 (Lit. 21.17)	1282 - Hb. 101 (Lit. 21.34)
1264 - Hb. 101 (Lit. 21.16)	1281 - Hb. 101 (Lit. 21.33)
1263 - Hb. 101 (Lit. 21.15)	1280 - Hb. 101 (Lit. 21.32)
1262 - Hb. 101 (Lit. 21.14)	1279 - Hb. 101 (Lit. 21.31)
1261 - Hb. 101 (Lit. 21.13)	1278 - Hb. 101 (Lit. 21.30)
1260 - Hb. 101 (Lit. 21.12)	1277 - Hb. 101 (Lit. 21.29)
1259 - Hb. 101 (Lit. 21.11)	1276 - Hb. 101 (Lit. 21.28)
1258 - Hb. 101 (Lit. 21.10)	1275 - Hb. 101 (Lit. 21.27)
1257 - Hb. 101 (Lit. 21.9)	1274 - Hb. 101 (Lit. 21.26)
1256 - Hb. 101 (Lit. 21.8)	1273 - Hb. 101 (Lit. 21.25)
1255 - Hb. 101 (Lit. 21.7)	1272 - Hb. 101 (Lit. 21.24)
1254 - Hb. 101 (Lit. 21.6)	1271 - Hb. 101 (Lit. 21.23)
1253 - Hb. 101 (Lit. 21.5)	1270 - Hb. 101 (Lit. 21.22)
1252 - Hb. 101 (Lit. 21.4 + NN)	1269 - Hb. 101 (Lit. 21.21)
1251 - Hb. 101 (Lit. 21.3 + NN)	1268 - Hb. 101 (Lit. 21.20)
1250 - Hb. 101 (Lit. 21.2 + NN)	1267 - Hb. 101 (Lit. 21.19)
1249 - Hb. 101 (Einleitung - Lit. 21.1)	1266 - Hb. 101 (Lit. 21.18)
1248 - Hb. 101 (Einleitung)	
1247 - Hb. 101 (Einleitung)	

Hb. 101.1-14
(DOI 10.17171/2-8-172)

Hb. 101.15-48
(DOI 10.17171/2-8-172)

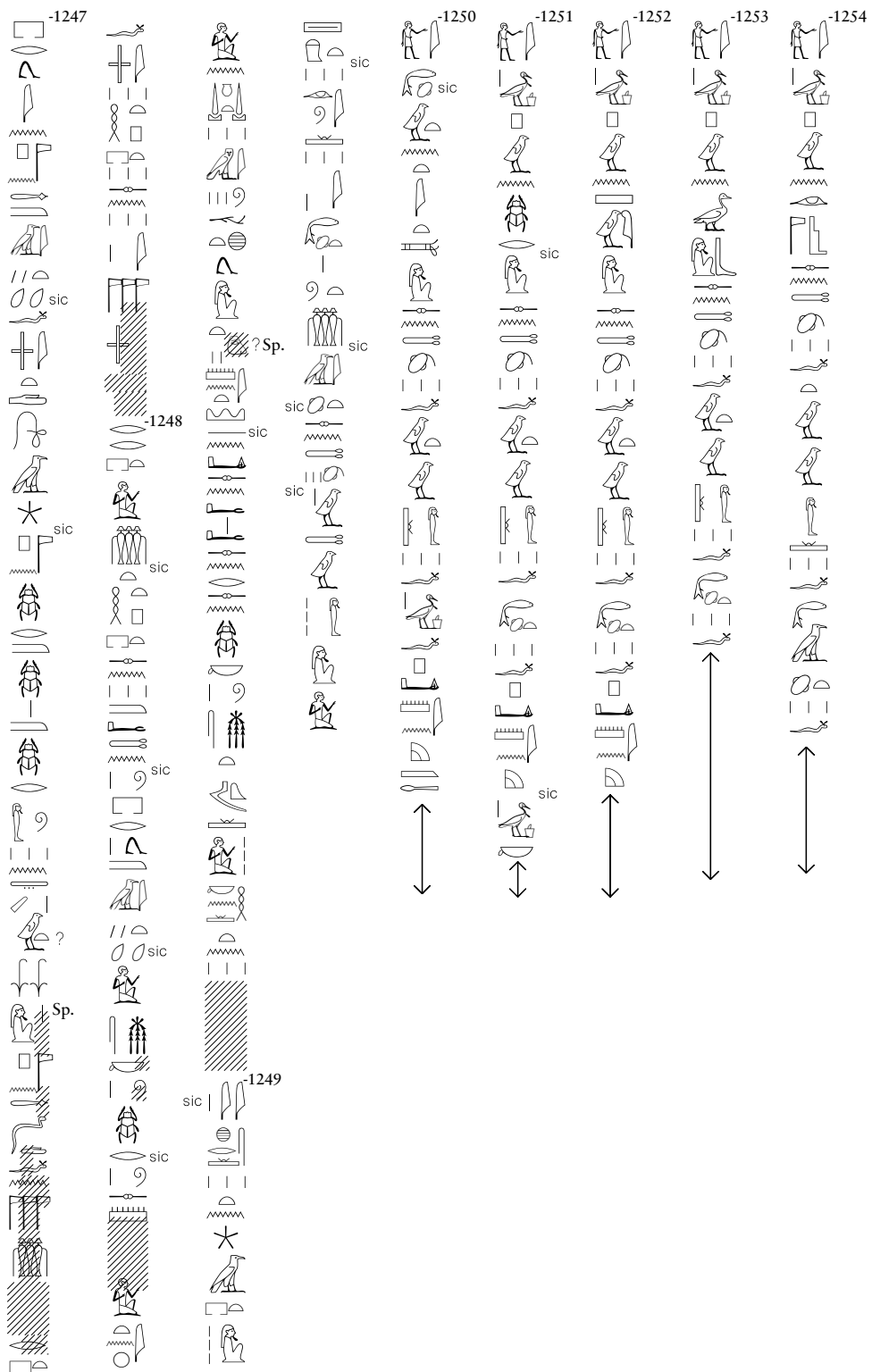

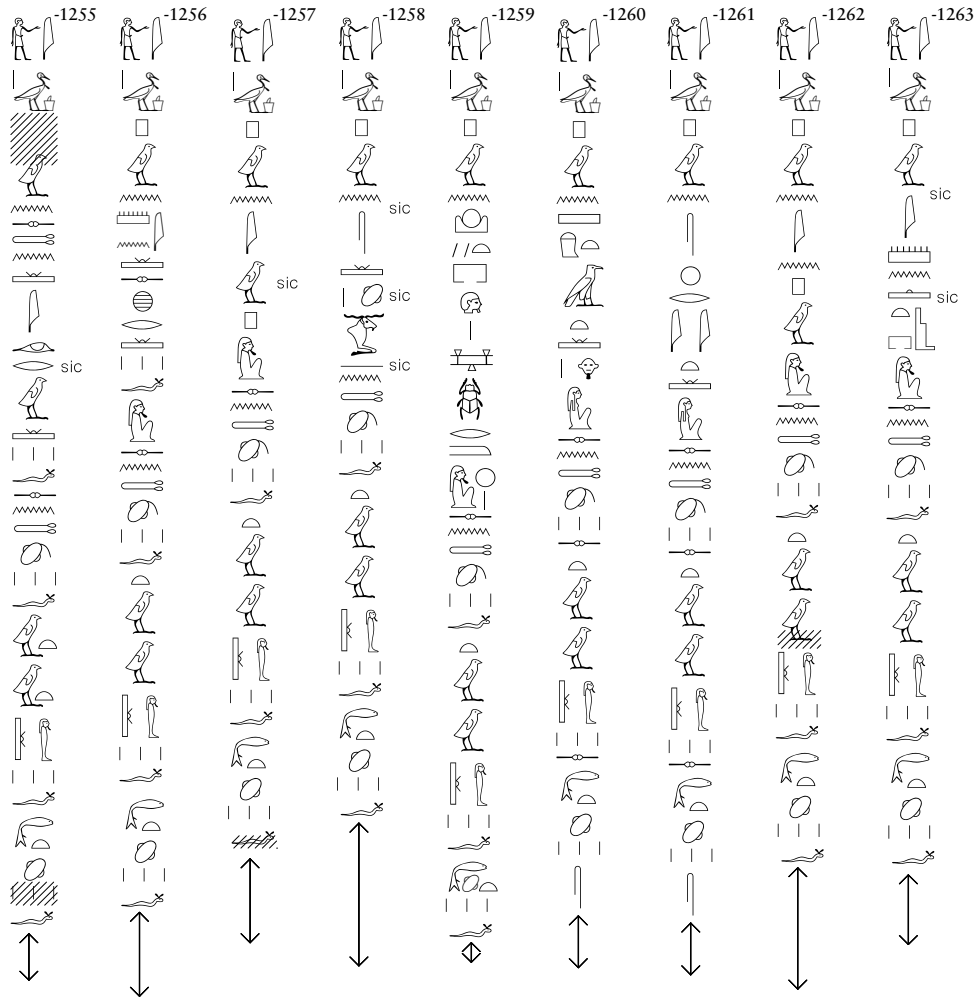

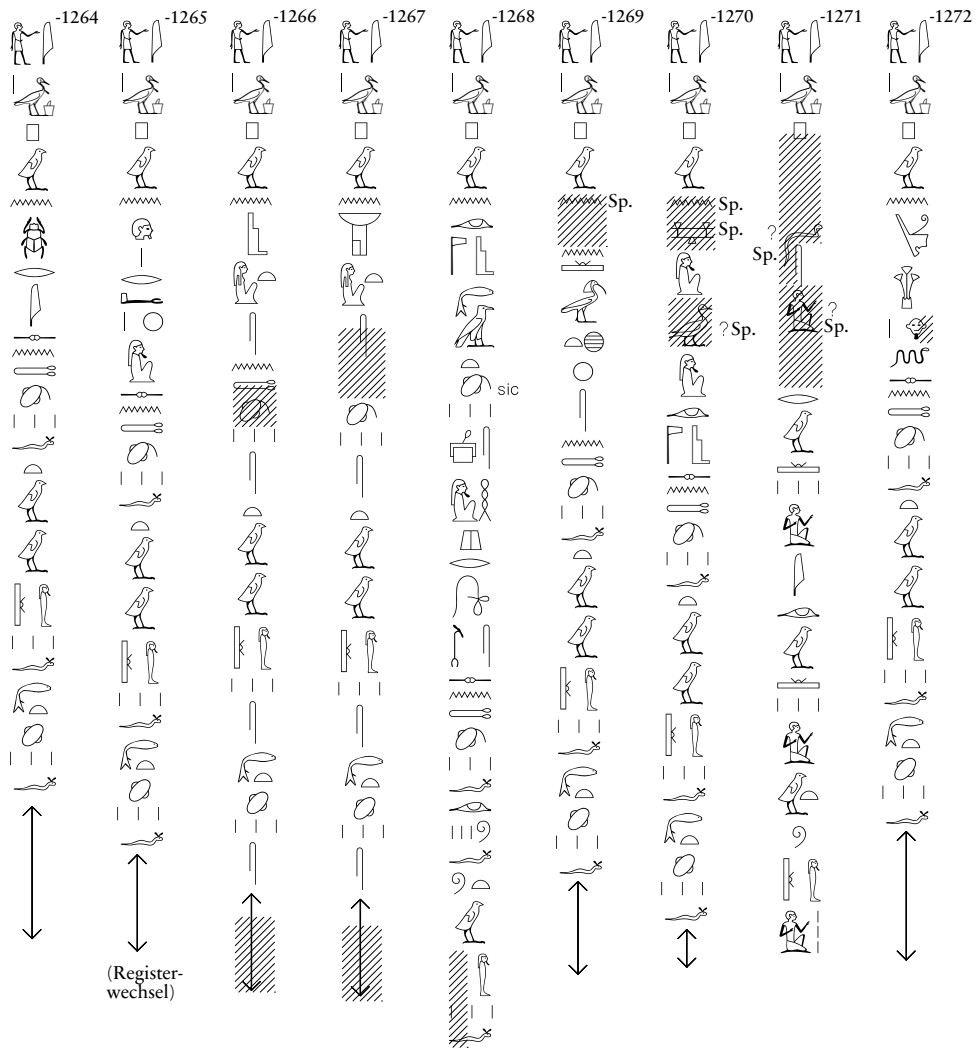

-1282
(Wandende)



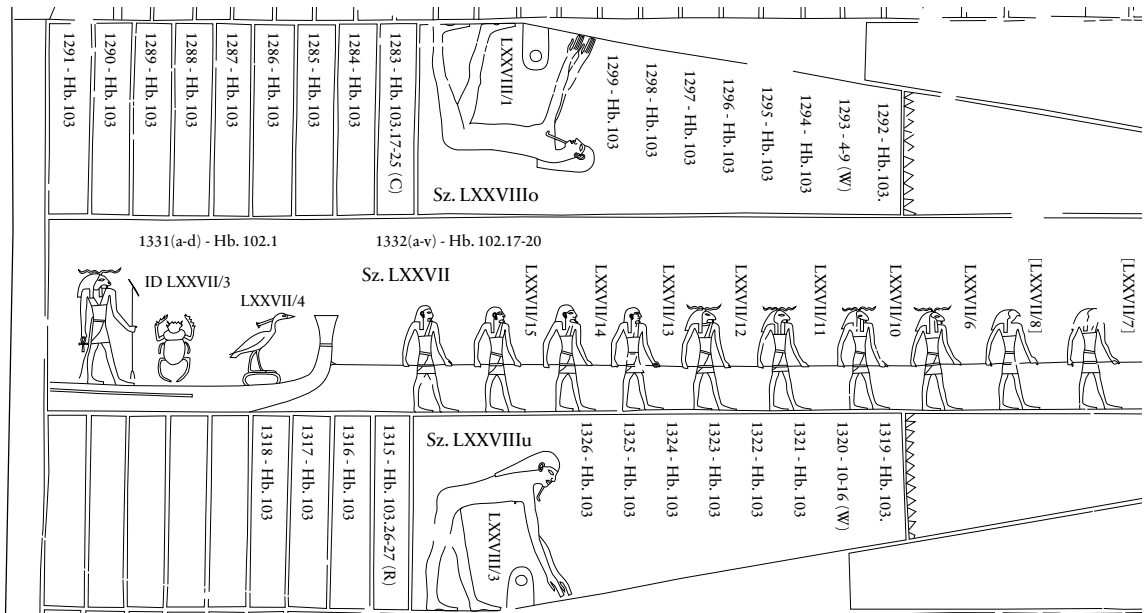

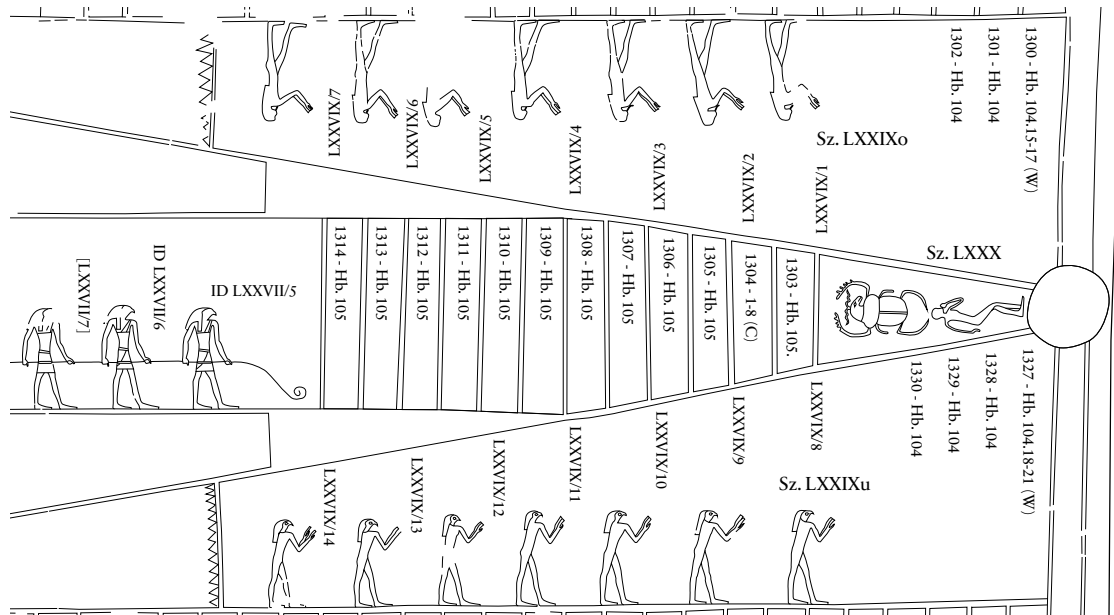

Hb. 102.17-20 (DOI 10.17171/2-8-70)

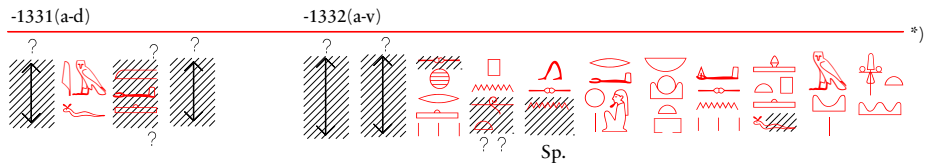

Hb. Sz. LXXVII
(DOI 10.17171/2-8-70)

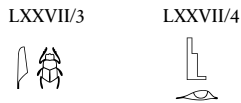

*) Hieroglyphen in rot, kaum sichtbar.

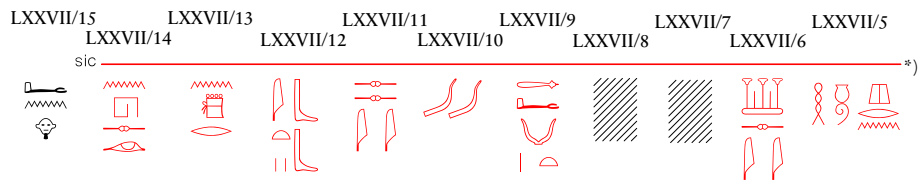

Hb. 105 (DOI 10.17171/2-8-176)

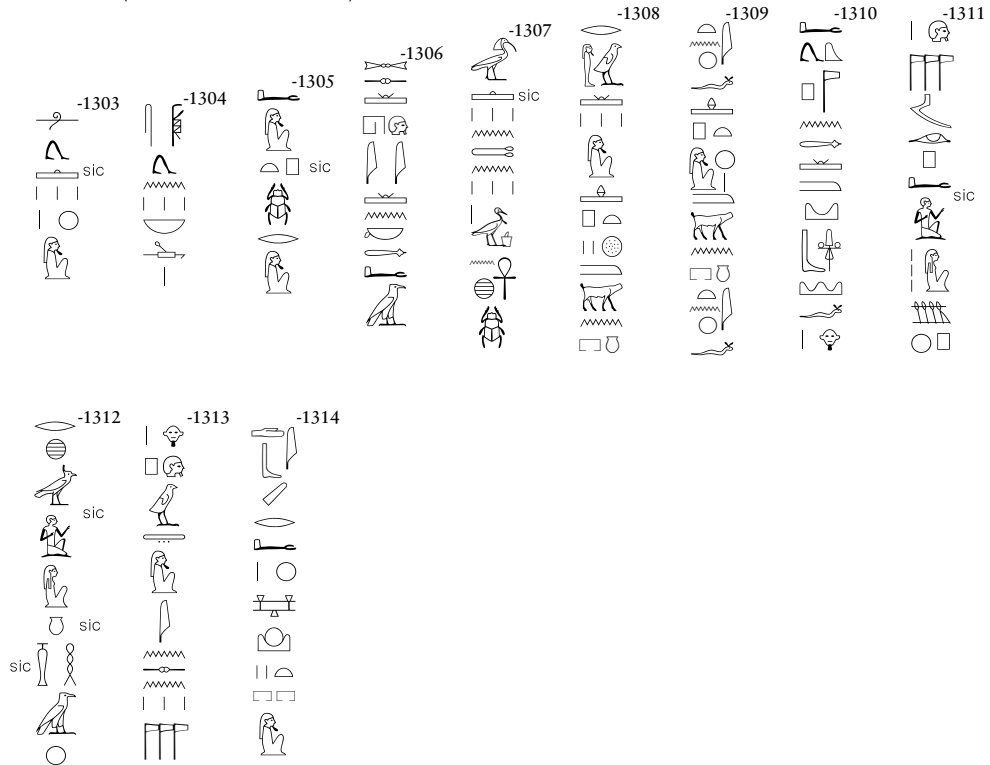

Hb. 103.17-25 (DOI 10.17171/2-8-174)

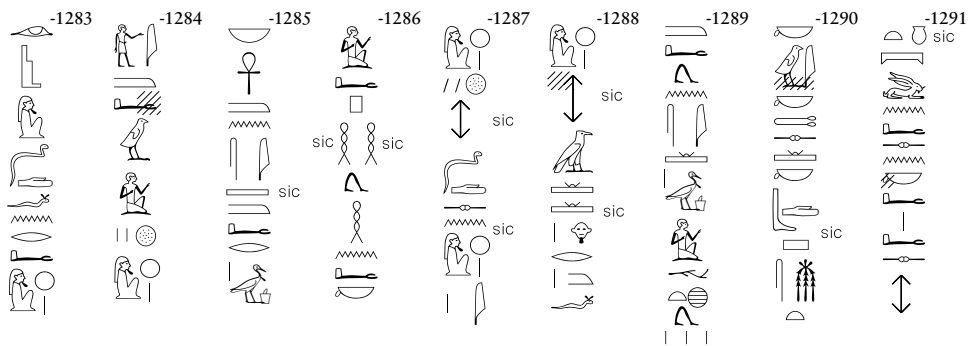

Hb. Sz. LXXVIIIo (DOI 10.17171/2-8-71)

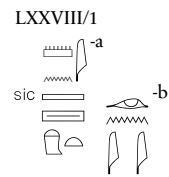

Hb. 103.4-9 (DOI 10.17171/2-8-174)

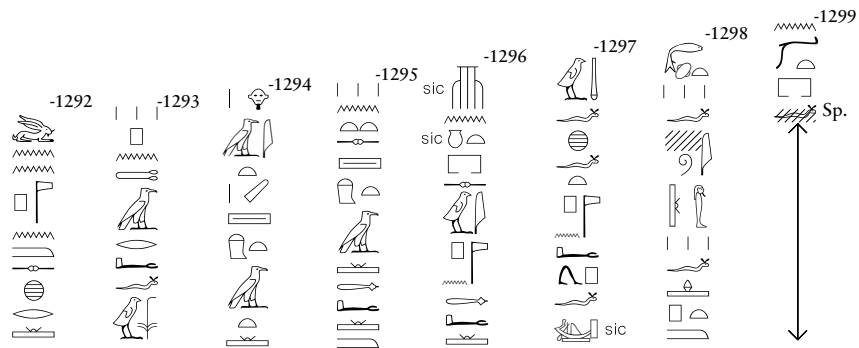

Hb. 103.26-27 (DOI 10.17171/2-8-174)

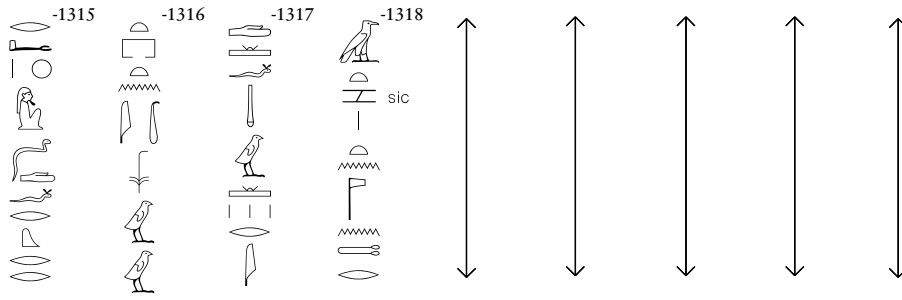

Hb. Sz. LXXVIIIu (DOI 10.17171/2-8-71)



Hb. 103.10-16 (DOI 10.17171/2-8-174)

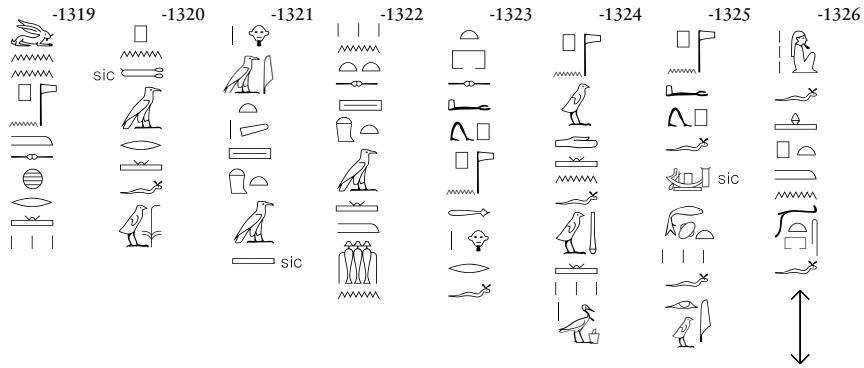

Hb. 104.15-17 (DOI 10.17171/2-8-175)

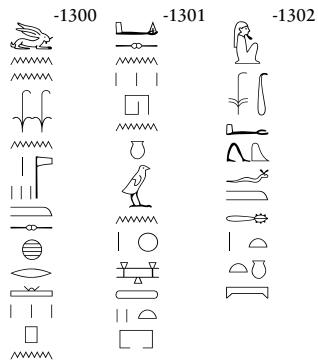

LXXIX/7



LXXIX/6



LXXIX/5

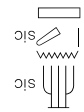

LXXIX/4



LXXIX/3



LXXIX/2



LXXIX/1

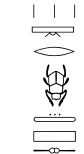

Hb. Sz. LXXIXo
(DOI 10.17171/2-8-72)
Hb. Sz. LXXIXu

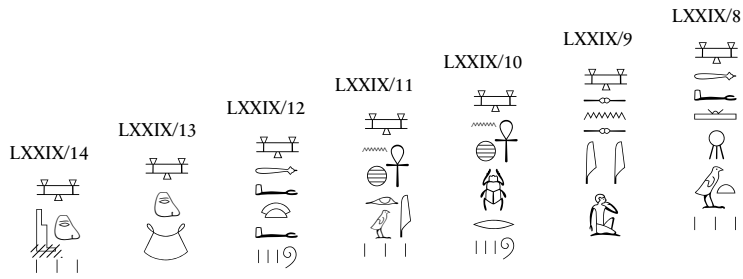

Hb. 104.18-21 (DOI 10.17171/2-8-175)

