

Tafeln 1-111

Das Copyright für alle dargestellten Fotos, Pläne und sonstigen Abbildungen liegt, sofern nicht anders vermerkt, beim »Deir Anba Hadra-Projekt« des DAI Kairo. Urheber der Fotos und Zeichnungen ist, sofern nicht anders angegeben, der Verfasser dieser Arbeit, die Pläne und 3D-Modelle sind von Klara Czarnitzki nach den Vorgaben durch den Verfasser erstellt worden. Die zugrunde liegenden Grundrisszeichnungen wurden durch den Verfasser und Hannah Sonbol angefertigt.

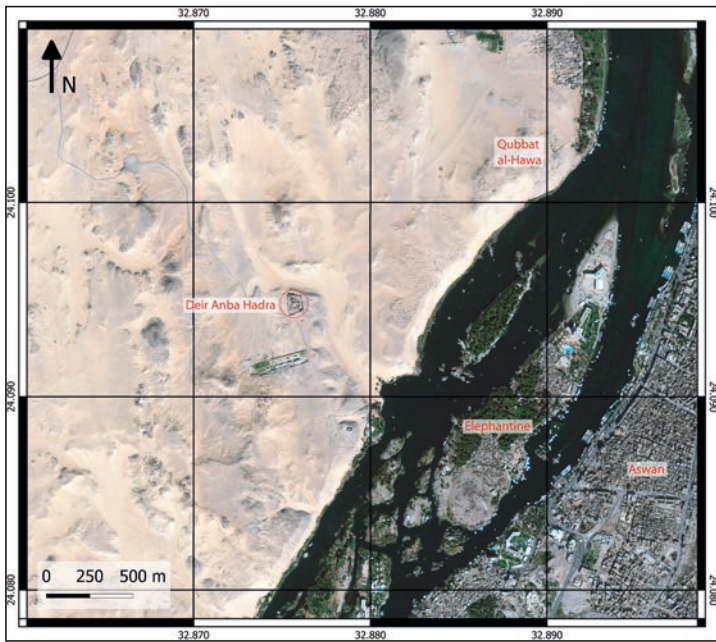

a Übersichtskarte der Umgebung. – b Gesamtansicht. Blick nach W. – c Gesamtanlage des Deir Anba Hadra. – (a nach Lehmann, Deir Anba Hadra Abb. 1; b Foto S. Olschok; c nach Grossmann, Christliche Archäologie Abb. 176).

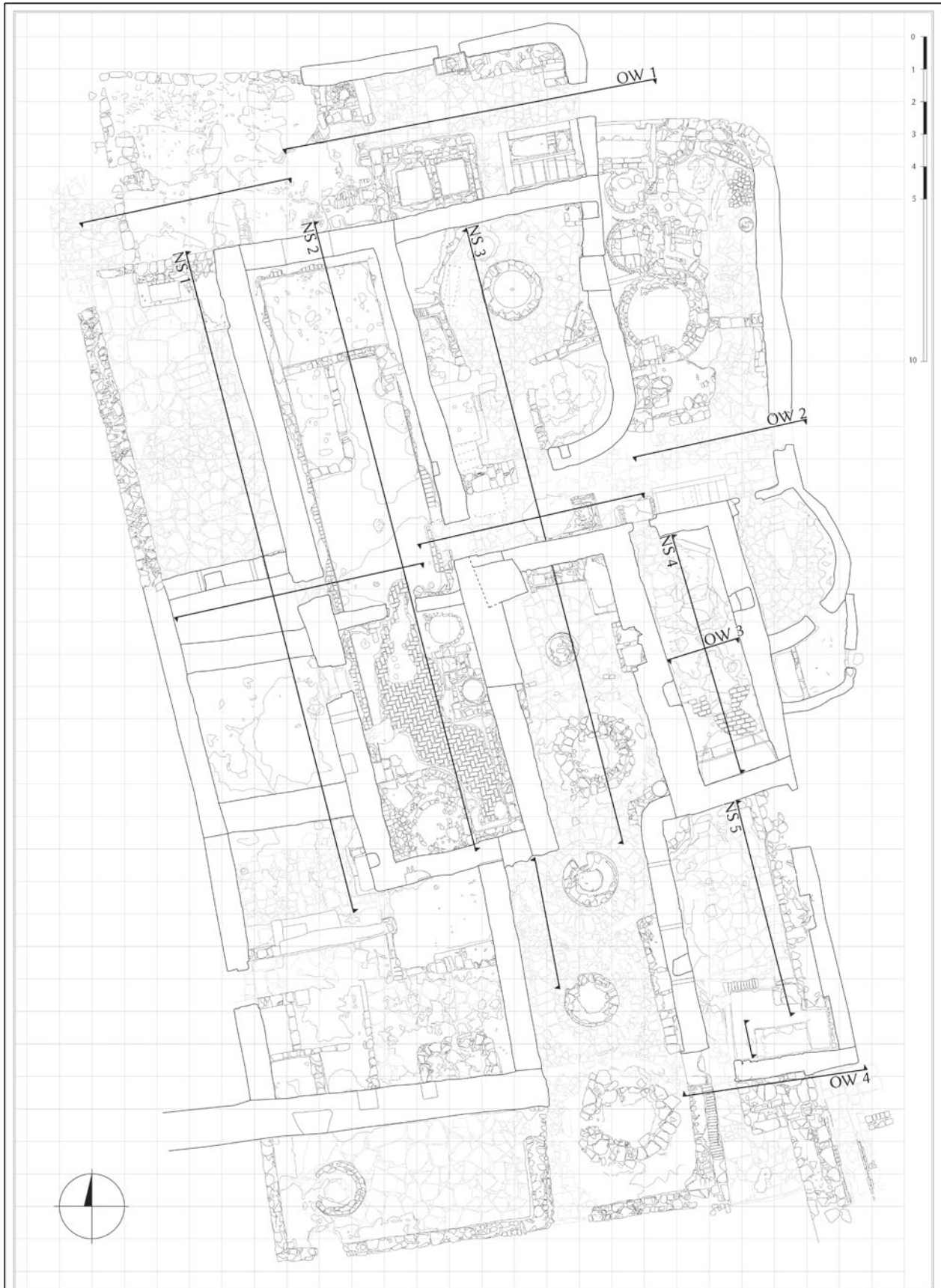

Lokalisierung der Ansichtsschnitte. – (Plan K. Czarnitzki/S. Olschok).

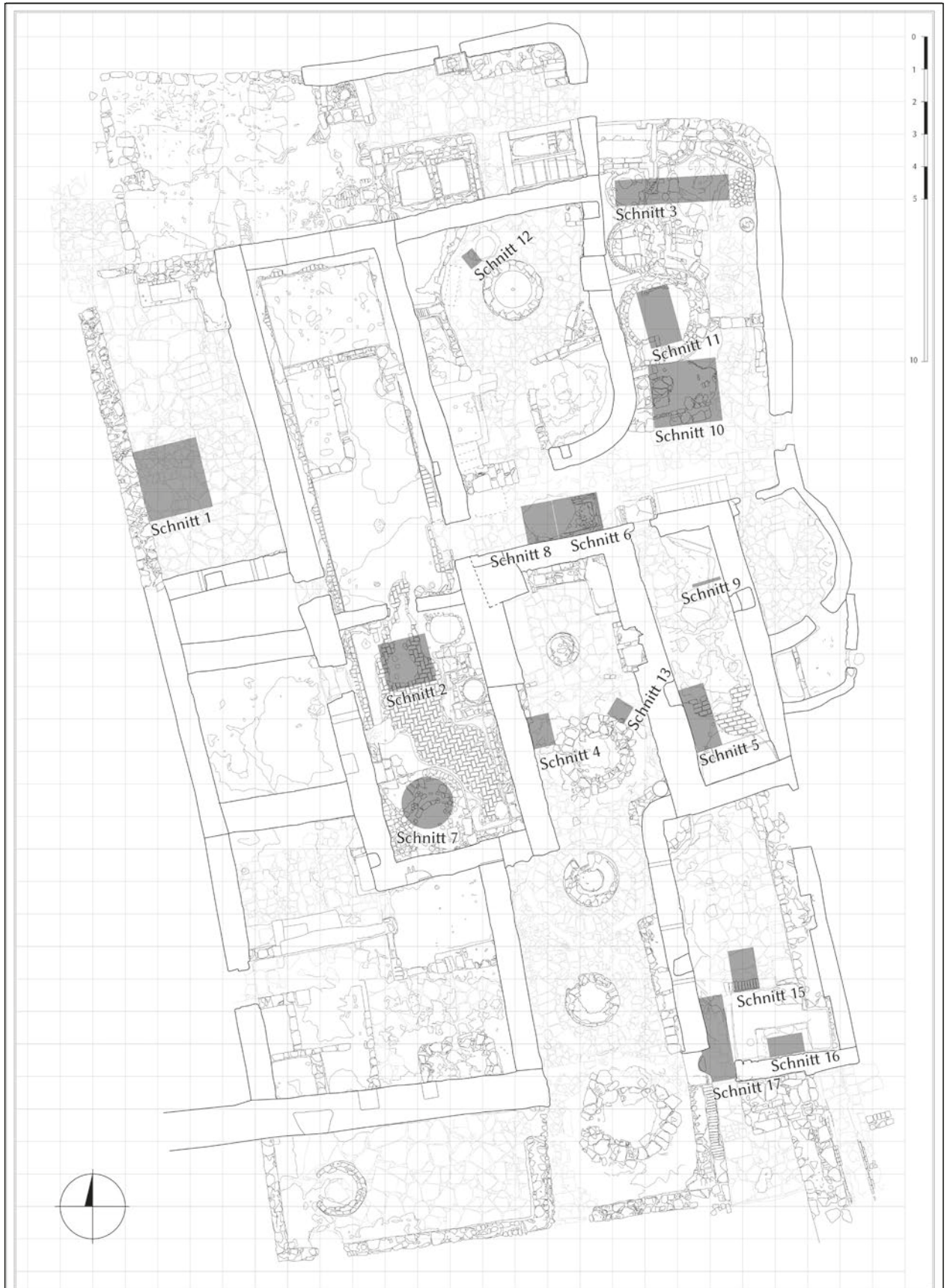

Lokalisierung der Grabungsschnitte und Sondagen. – (Plan K. Czarnitzki/S. Olschok).

Tafel 4

Fundplatz Deir Anba Hadra		Raum	Schnitt	Befund
<input type="checkbox"/> regulär <input type="checkbox"/> Baubefund <input type="checkbox"/> Bestattung		Fotonummer(n)	Zeichenblattnummer(n)	Profilnummer(n)
Grabungsmethode <input type="checkbox"/> natürlich <input type="checkbox"/> künstlich		Bearbeiter/in	Geöffnet	Geschlossen
Sediment <input type="checkbox"/> sandig <input type="checkbox"/> lehmig <input type="checkbox"/> schluffig <input type="checkbox"/> humos <input type="checkbox"/> anderes		Farbe <input type="checkbox"/> weißlich <input type="checkbox"/> gelblich <input type="checkbox"/> graulich <input type="checkbox"/> bräunlich <input type="checkbox"/> schwärzlich <input type="checkbox"/> rotlich		Einschlüsse <input type="checkbox"/> viel <input type="checkbox"/> wenig <input type="checkbox"/> keine
Konsistenz <input type="checkbox"/> sehr hart <input type="checkbox"/> hart <input type="checkbox"/> mittel <input type="checkbox"/> locker <input type="checkbox"/> sehr locker		Verunreinigungen/Störungen <input type="checkbox"/> keine <input type="checkbox"/> gering <input type="checkbox"/> stark		Aeolische Holzkohle gebrannter Lehm Mörtel-/Ziegelreste Botanische Reste Splitt (< 2 cm, kantig) Altkies (< 2 cm, rund) Schotter (2-6 cm, kantig) Grobkies (2-6 cm, rund) Steine (6-20 cm)
Maße (L/B/T/Dm/L2/L3)		Beschreibung		
Vorläufige Interpretation		Funde <input type="checkbox"/> Keramik <input type="checkbox"/> Knochen <input type="checkbox"/> Bodensprobe <input type="checkbox"/> Textil <input type="checkbox"/> Putz <input type="checkbox"/> Botanik <input type="checkbox"/> Leder <input type="checkbox"/> Glas <input type="checkbox"/> Ostrakon <input type="checkbox"/> Papyrus		
Lagekizze		Vermessungspunkte		
+		Punkt: Höhe Punkt: Höhe		
+		unter wird versiegelt von verfüllt mit wird geschritten von innerhalb enthält äquivalent zu gleicher Bef. wie stößt an über versiegelt Vorfüllung von schneidet		

a

Deir Anba Hadra	Room
Section	Context
Date	Finder
Object	

b

Fundplatz Deir Anba Hadra		Raum	Gebäude	Bearbeiter/in
Raubuch		Datum	Schnittsummere	
Maße (L/B)		Quadratmeter	Bodenbelag	
Wandausstattung (Mauer) - Putz		Deckenkonstruktion		
Ansprache / Beschreibung		Installationen		
Angrenzende Räume	N	O	S	W
Erschlossen durch	Erschlossen durch	Erschlossen durch	Erschlossen durch	
Begrenzt durch Mauern	Begrenzt durch Mauern	Begrenzt durch Mauern	Begrenzt durch Mauern	
Lagekizze		FB Niveau		
+		Punkt: Höhe Punkt: Höhe		
+		unter wird versiegelt von verfüllt mit wird geschritten von innerhalb enthält äquivalent zu gleicher Bef. wie stößt an über versiegelt Vorfüllung von schneidet		

c

Fundplatz Deir Anba Hadra		Räume	Gebäude	Mauernummer
Mauerbuch		Datum	Wirtschaftskomplex	Bearbeiter/in
Mauerlänge		max. sichtbare Höhe	Schnittsummere	Ötschok
Öffnungen		Installationen	Höhe Mauerkante u/N	Anzahl erhaltene Steinslagen
Mauertechnik		Schalenfüllung	Mauerstärke	Fundament erhalten / zugruben
<input type="checkbox"/> Einschalig <input type="checkbox"/> Zweischalig verzahnt?		Mörtel <input type="checkbox"/> Spolien Steinformat	Lagerfugen <input type="checkbox"/> regelmäßig <input type="checkbox"/> unregelmäßig <input type="checkbox"/> durchgehend <input type="checkbox"/> Schalenw.durchgehend	Mörtel Zusätze <5cm / >5cm / Keramik / Kiesel
Ansichtsskizze 1	Maße	<input type="checkbox"/> bruchrau <input type="checkbox"/> gespitzt / gestockt / acharliert <input type="checkbox"/> glatt <input type="checkbox"/> bossiert <input type="checkbox"/> grub-gogglittet	<input type="checkbox"/> regelmäßig, nicht lagerhaft <input type="checkbox"/> partiell lagerhaft <input type="checkbox"/> ungleichmäßige Lagen <input type="checkbox"/> lagerhaft <input type="checkbox"/> regelmäßig, lagerhaft	Verbandskizze (Läufer, Binder, Roller)
Ansichtsskizze 2	Maße	<input type="checkbox"/> bruchrau <input type="checkbox"/> gespitzt / gestockt / acharliert <input type="checkbox"/> glatt <input type="checkbox"/> bossiert <input type="checkbox"/> grub-gogglittet	<input type="checkbox"/> regelmäßig, nicht lagerhaft <input type="checkbox"/> partiell lagerhaft <input type="checkbox"/> ungleichmäßige Lagen <input type="checkbox"/> lagerhaft <input type="checkbox"/> regelmäßig, lagerhaft	Verbandskizze (Läufer, Binder, Roller)
Beschreibung / Interpretation / Bemerkungen (Bauphase, Orig, Mauerkante, Verwitterung/etzungen/Verkipungen/Verputz/Steinsockel/Fundamentbeschaffenheit)				
Skizzen		unter wird geschritten von		
		Verband mit Fuge, gleichzeitig mit äquivalent zu gleicher Bef. wie		
		über Fuge, angesetzt an schneidet		

d

Blankoformulare. a Befundformular. – b Fundzettel. – c Raumbuchformular. – d Mauerbuchformular. – (Entwurf S. Olschok).

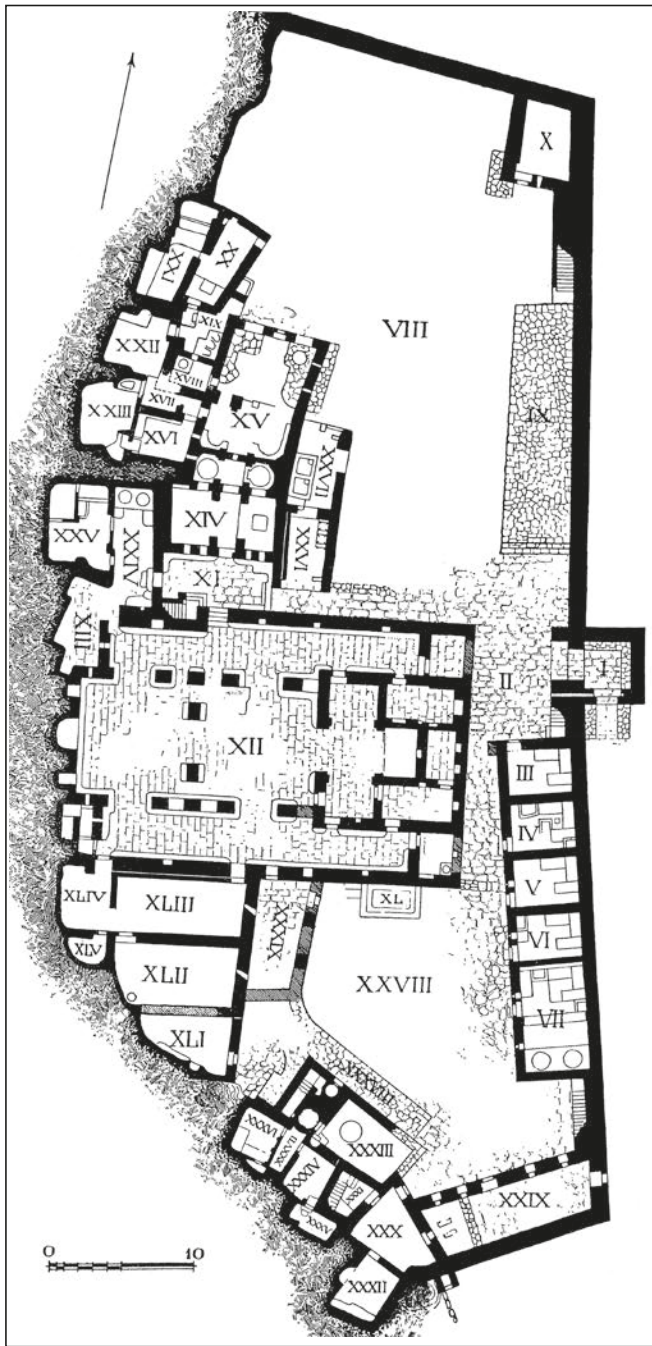

b



c



d



e

Untere Terrasse. **a** Grundrissplan. – **b** Grotte. Blick nach S. – **c** Klosterkirche. Blick nach O. – **d** Gebäudekomplex nördlich der Kirche. Blick nach SO. – **e** Hof im S der Klosterkirche. Blick nach NO. – (a nach Monneret de Villard, *Monastero Abb. 39*; b-e Fotos S. Olschok).



b



c



d



e



f



g

Obere Terrasse. a Grundrissplan. – b Qasr. Blick nach NO. – c Klosterzelle. Blick nach W. – d Refektorium OT_111. Blick nach S. – e Obere Terrasse SO-Teil. Blick nach NO. – f Platz OT_40 mit umliegenden Gebäuden. Blick nach N. – g Tennenofen OT_19. Blick nach SW. – (a nach Monneret de Villard, Monastero Abb. 87; b-g Fotos S. Olschok).

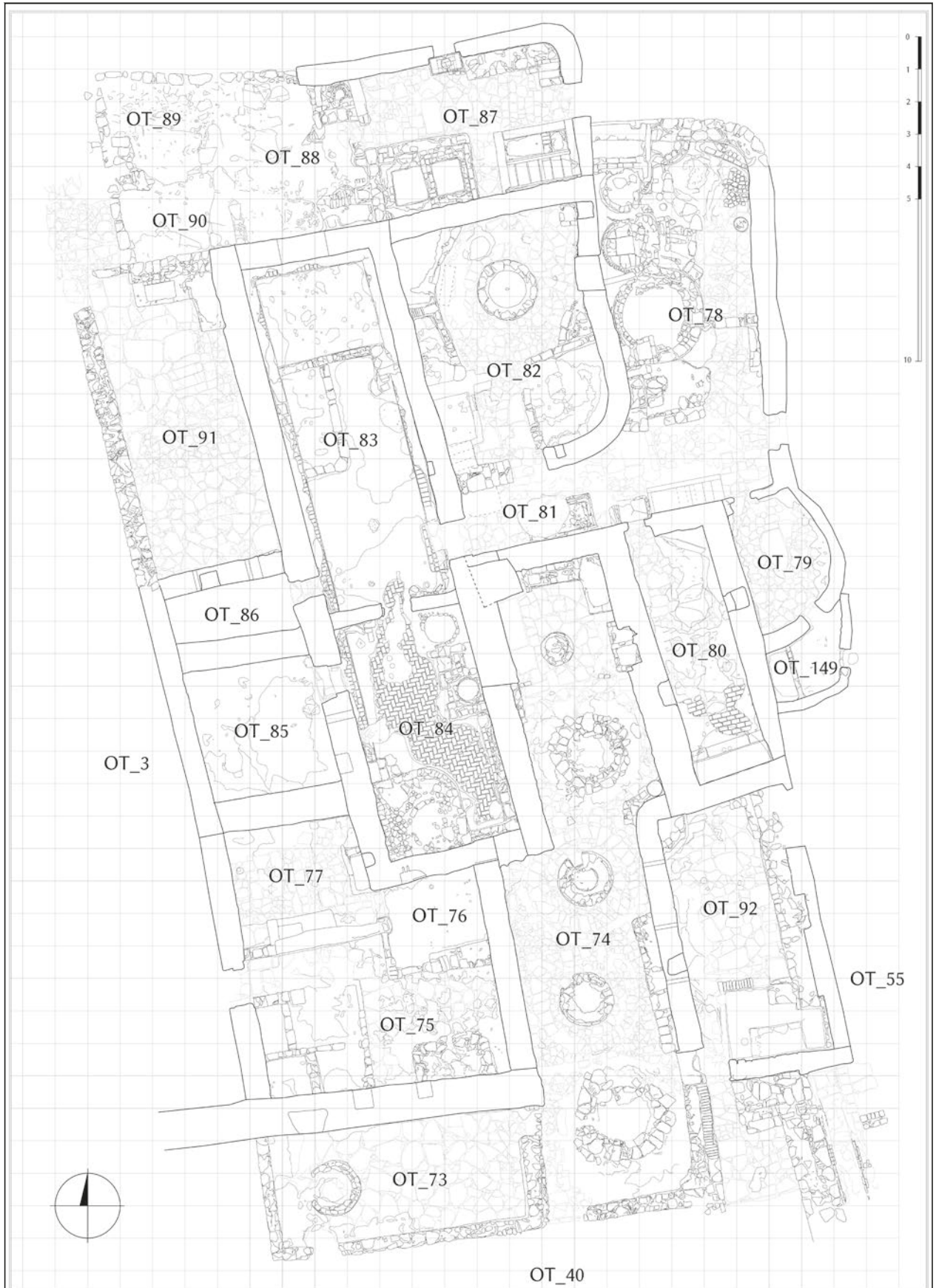

Grundrisszeichnung des Baukomplexes mit Raumnummern.– (Plan K. Czarnitzki/S. Olschok).

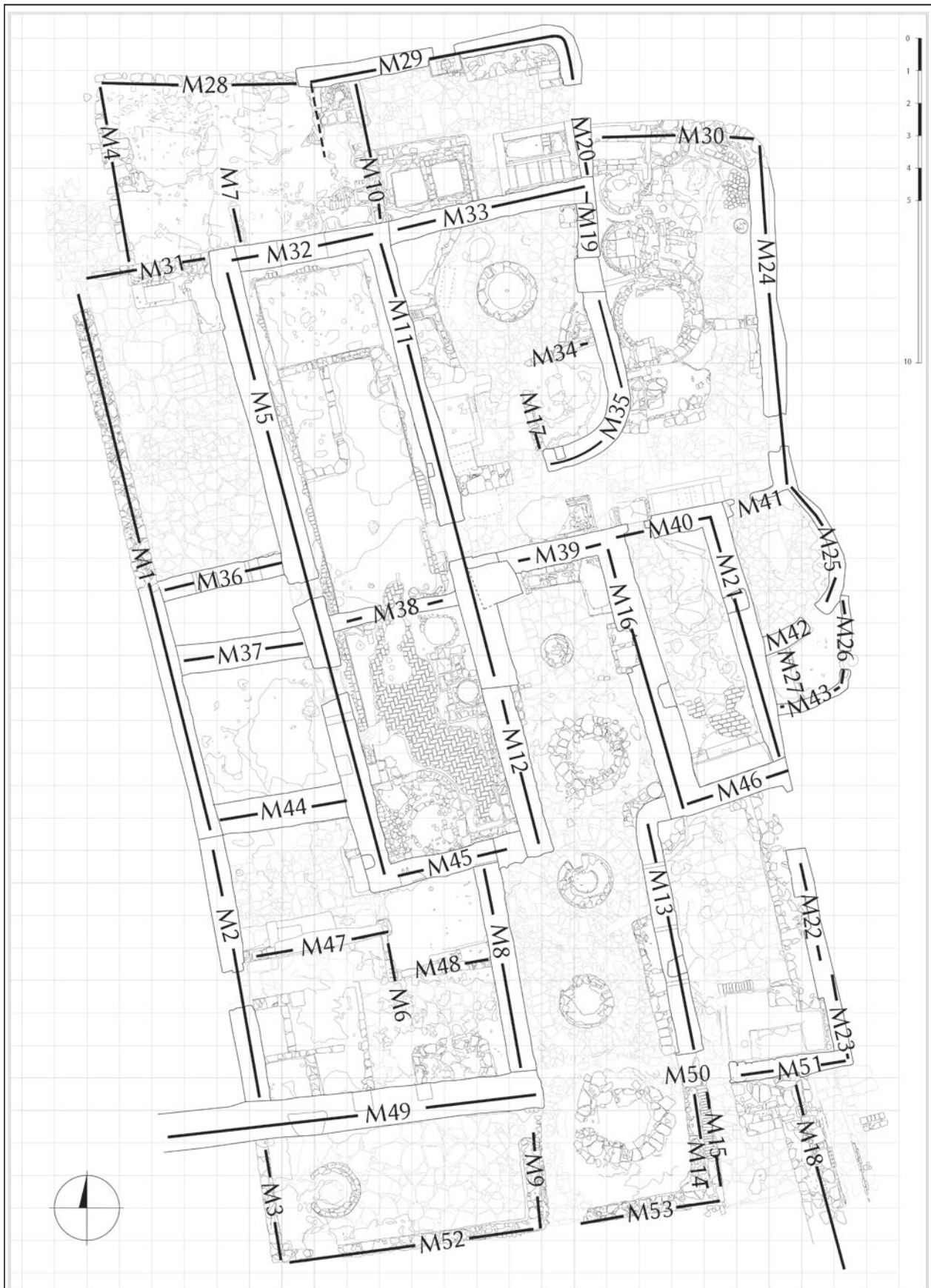

Grundrisszeichnung des Baukomplexes mit Mauernummern. – (Plan K. Czarnitzki/S. Olschok)

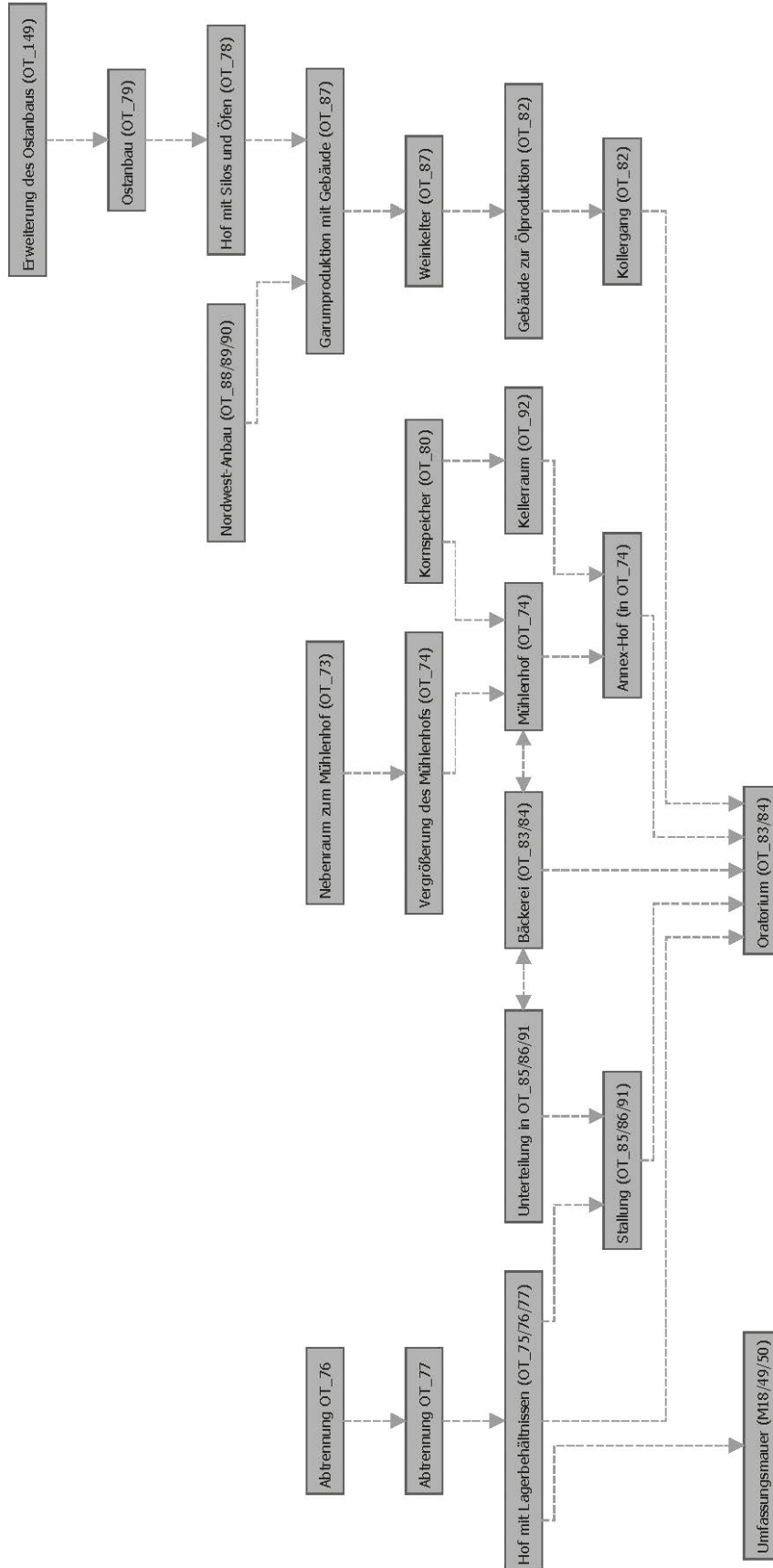

Harris-Matrix-Abfolge der Mauern. – (Diagramm S. Olschok).



a

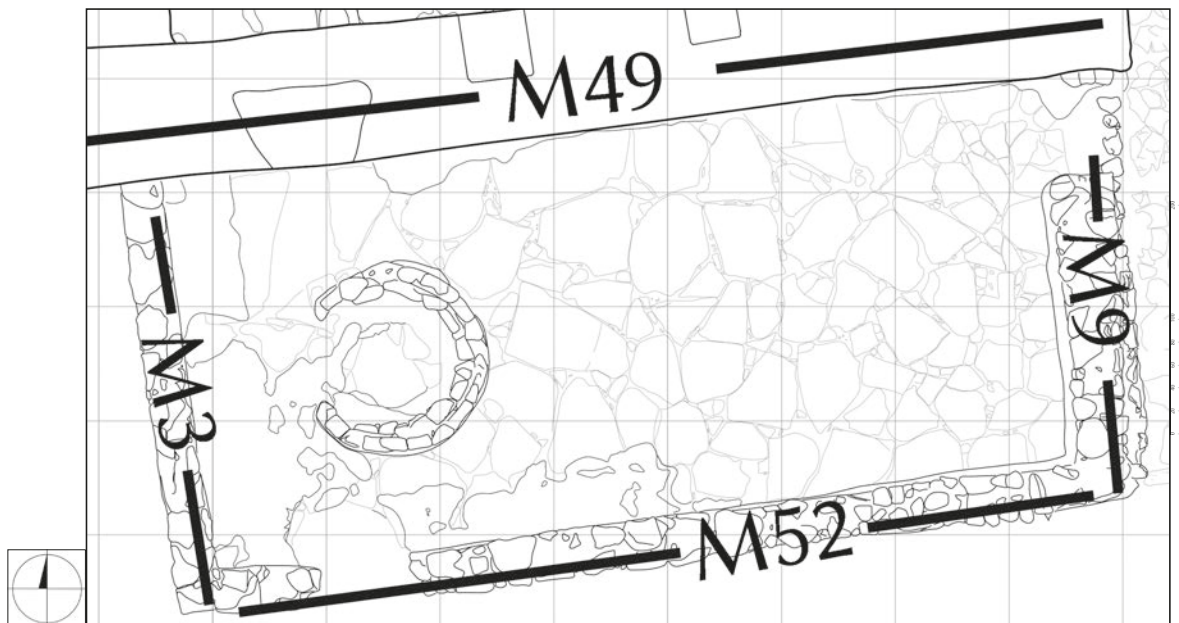

b



c

a Übersicht »Wirtschaftskomplex«. Blick nach S. – b OT_73. Grundrisszeichnung. – c OT_73. Blick nach SW. – (a, c Fotos S. Olschok; b Plan K. Czarnitzki/S. Olschok).



a



b



c



d



e

Kreissegmente aus Sandstein, gefunden in OT_73. – a Segment 1. – b Segment 2. – c Segment 3. – d Segment 4. – e Segment 5. – (Fotos S. Olschok).

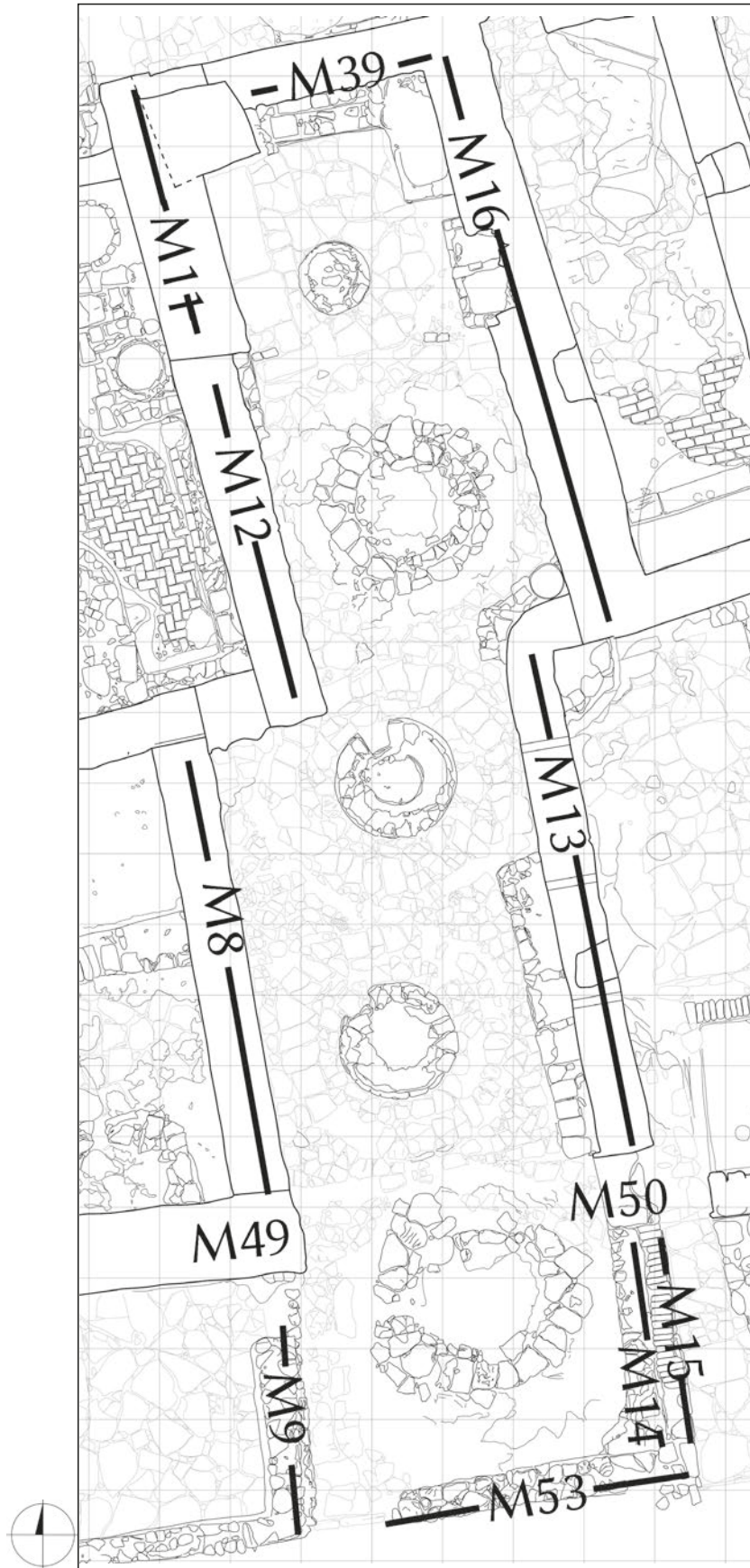

OT_74. Grundrisszeichnung. – (Plan K. Czarnitzki/S. Olschok).



a



b

OT_74. a Blick nach S. – b Blick nach N. – (Fotos S. Olschok).



a

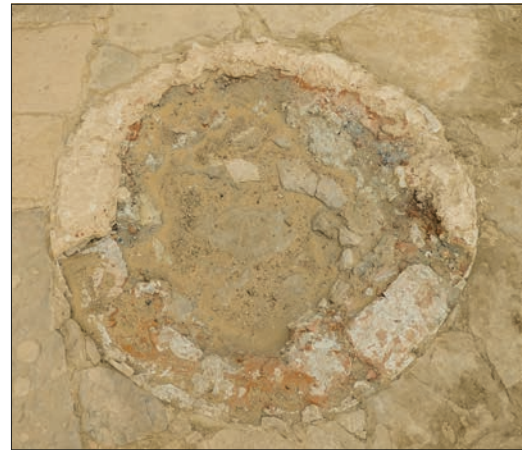

b



c

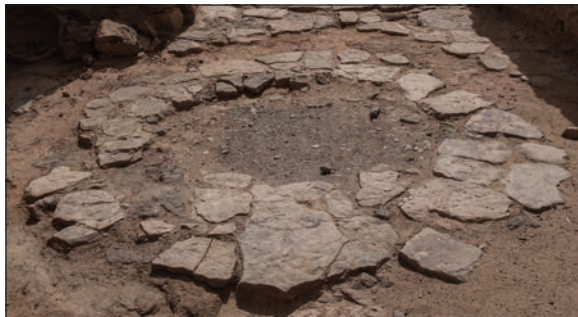

f



d



g



e

OT_74. a Bett und Nische. Blick nach SO. – b Becken. – c-d Mühlenstandorte. Blick nach SW. – e-f Mühlenstandorte. Blick nach N. – g Wasserinstallation. Blick nach SO. – (Fotos S. Olschok).



OT_75. a Grundrisszeichnung. – b Blick nach SW. – (a Plan K. Czarnitzki/S. Olschok; b Foto S. Olschok).



a



b

OT_75. a Blick nach NO. – b Becken in der SW-Ecke. Blick nach SW. – (a Foto S. Olschok; b Foto R. Bodenstein).

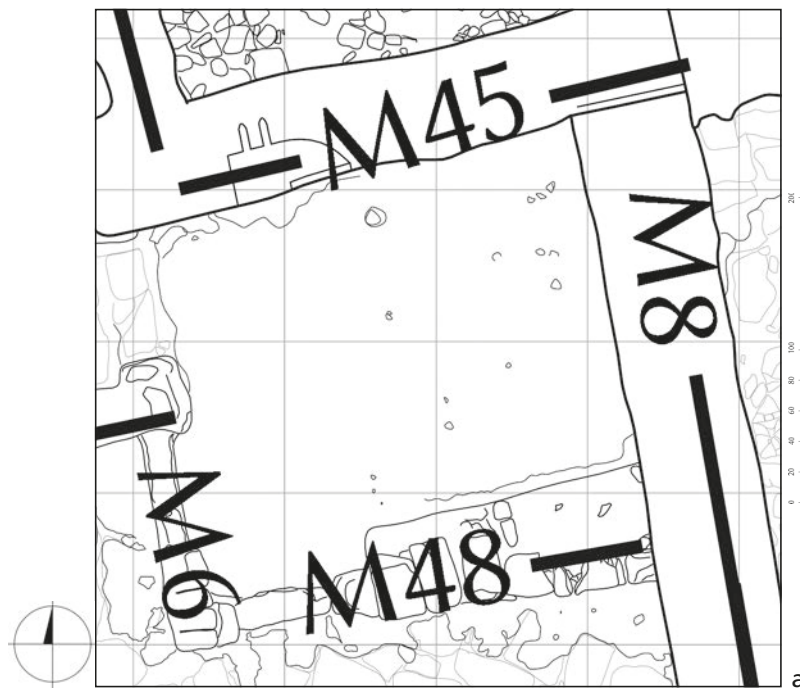

OT_76. a Grundrisszeichnung. – b Blick nach N. – (a Plan K. Czarnitzki/S. Olschok; b Foto S. Olschok).



OT_77. a Grundrisszeichnung. – b Blick nach NW. – (a Plan K. Czarnitzki/S. Olschok; b Foto R. Bodenstern).



a



b



c



d

OT_77. a Nischeninstallation im S. – b Becken mit Nische im O. – c M44. Blick nach N. – d M44. Blick nach S. – (a Foto R. Bodenstern; b-d Fotos S. Olschok).

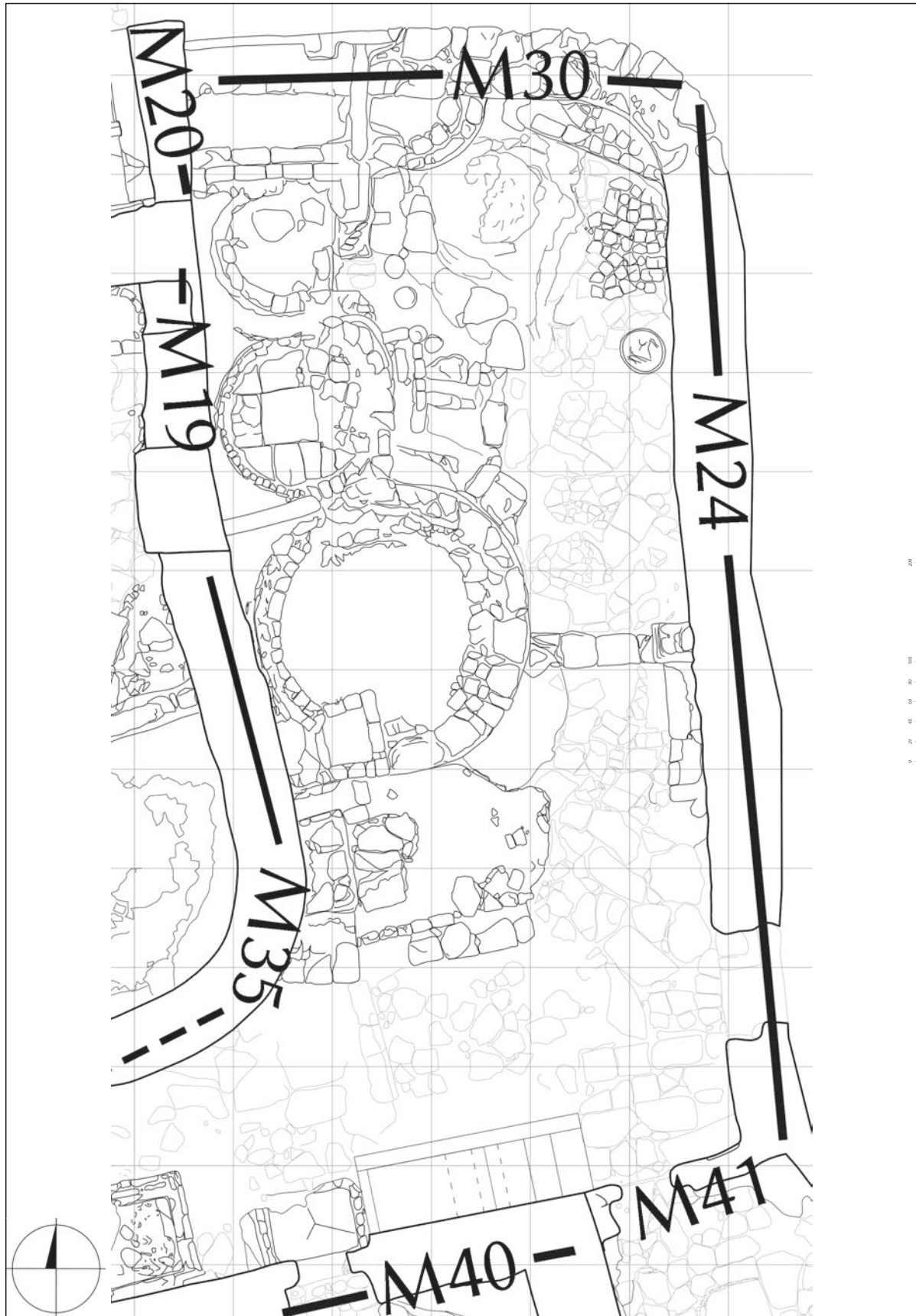

OT_78. Grundrisszeichnung. – (Plan K. Czarnitzki/S. Olschok).



a



b



c



d

OT_78. a Blick nach S. – b Silo. – c Öfen mit umgebenden Strukturen. – d O-Mauer. – (Fotos S. Olschok).

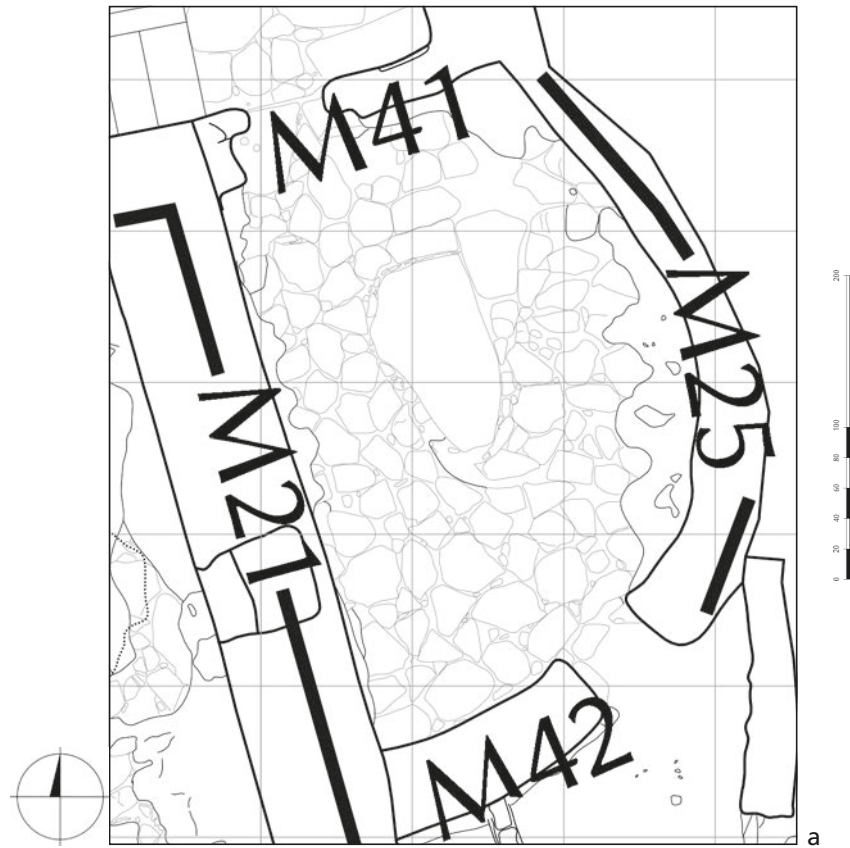

OT_79. a Grundrisszeichnung. – b Blick nach N. – (a Plan K. Czarnitzki/S. Olschok; b Foto R. Bodenstern).



OT_80. Grundrisszeichnung. – (Plan K. Czarnitzki/S. Olschok).



a



b



c

OT_80. a Blick nach S. – b Blick nach N. – c Obergeschoss. – (Fotos S. Olschok).

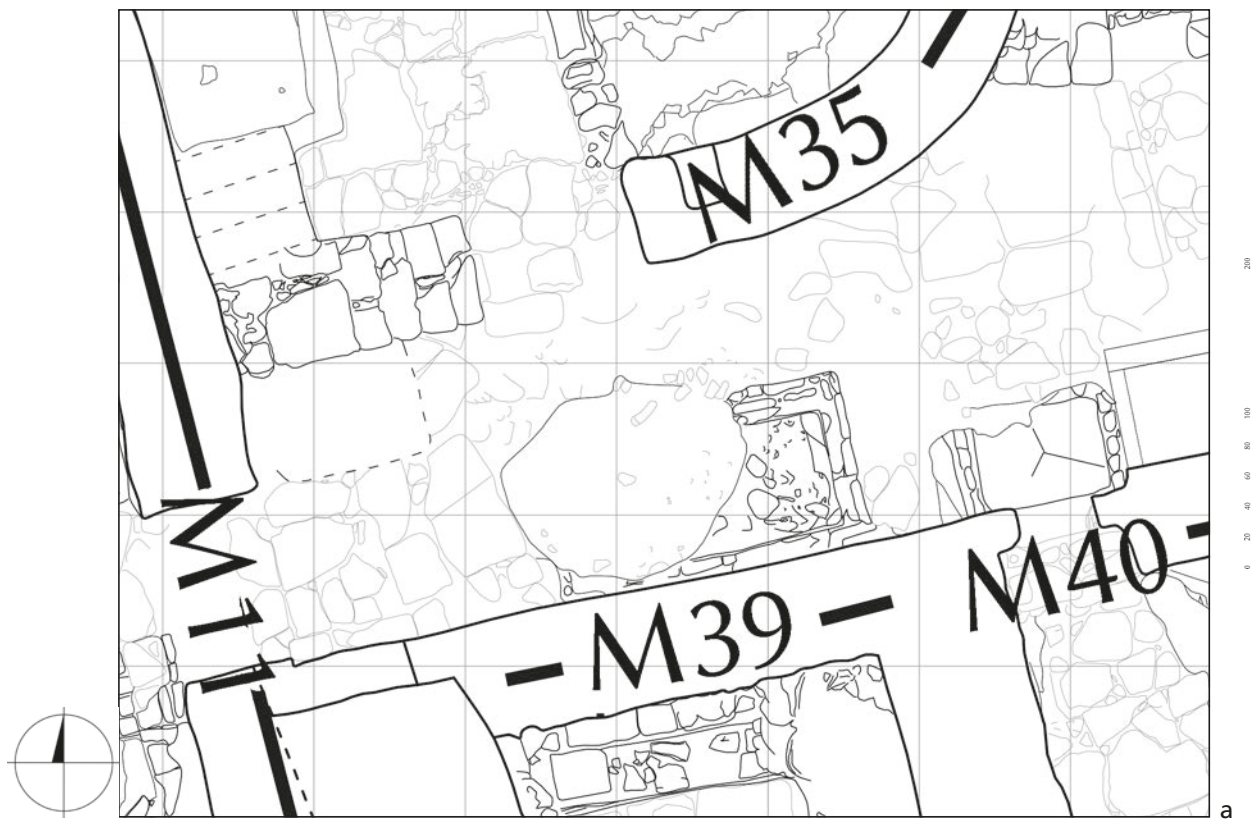

OT_81. **a** Grundrisszeichnung. – **b** Blick nach W. – **c** Blick nach O. – (a Plan K. Czarnitzki/S. Olschok; b-c Fotos S. Olschok).



a



b

Steinkiste in OT_81. **a** Blick nach N. – **b** historisches Foto. Blick nach W. – (a Foto S. Olschok; b Foto Johann Georg, Herzog zu Sachsen – Universitätsarchiv Freiburg [Bildnr. UAF C 0197_03359]).

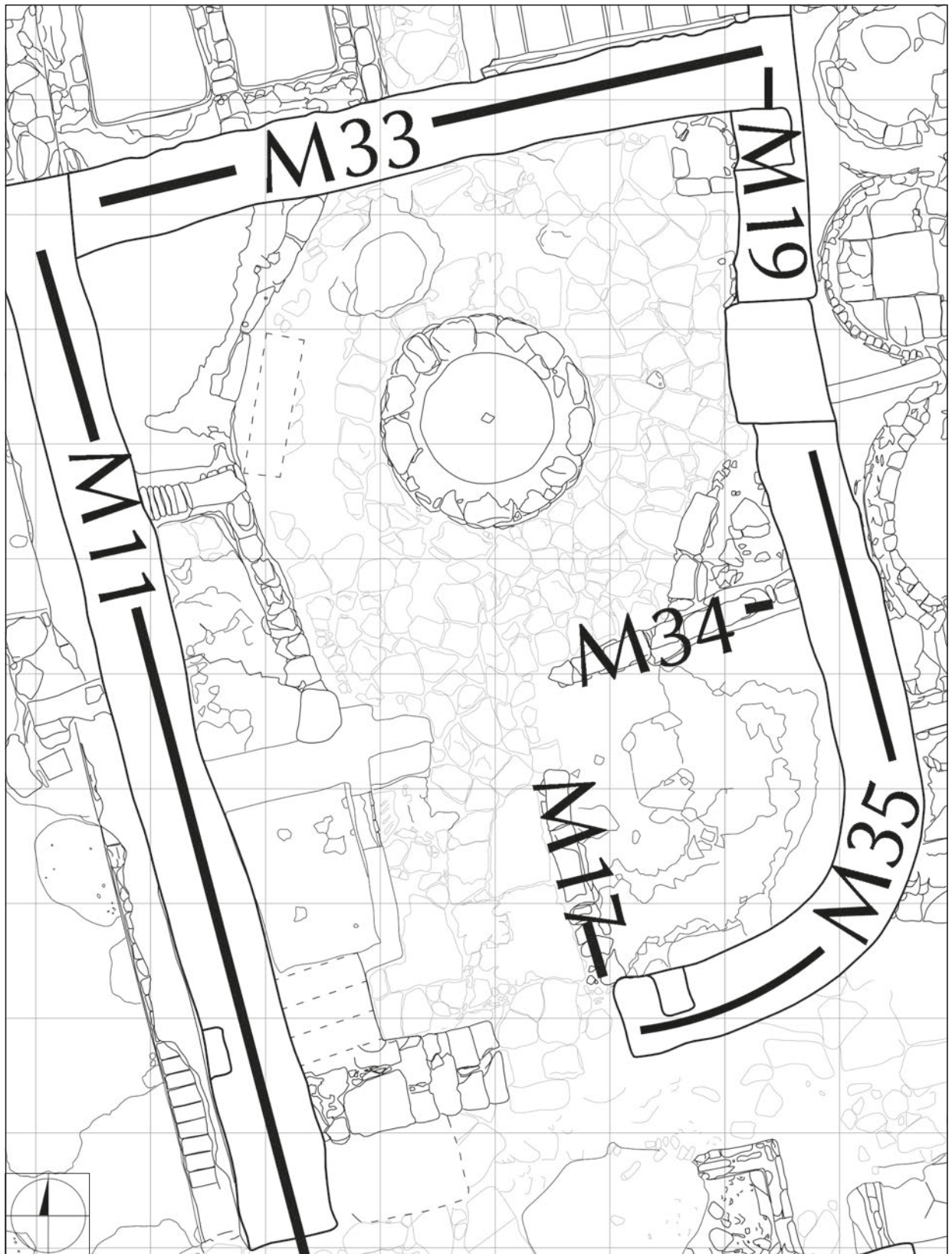

OT_82. Grundrisszeichnung. – (Plan K. Czarnitzki/S. Olschok).



a



b

OT_82. a Blick nach N. – b Blick nach S. – (Fotos R. Bodenstein).



a



b



c

OT_82. a Blick nach W. – b Blick in die SO-Ecke. – c Kollergang. – (Fotos S. Olschok).

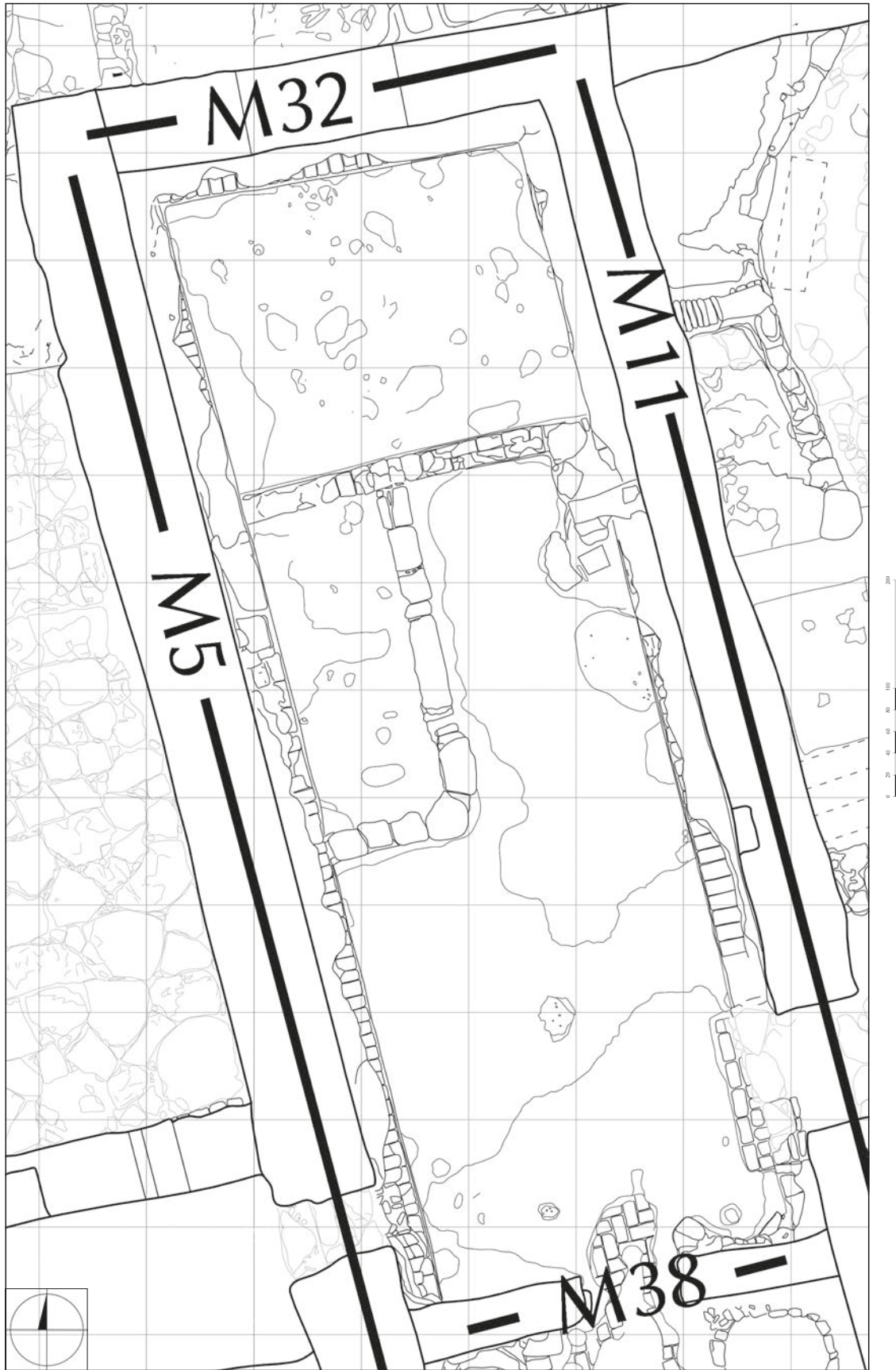

OT_83. Grundrisszeichnung. – (Plan K. Czarnitzki/S. Olschok).



a



b

OT_83. a Blick nach S. – b Blick nach NW. – (a Foto R. Bodenstein; b Foto S. Olschok).



a



b

OT_83. **a** Tür zwischen OT_83 und OT_84. Blick nach N. – **b** Schuttablagerung auf historischer Fotografie 1912. Blick nach N. – (a Foto S. Olschok; b Foto Johann Georg, Herzog zu Sachsen – Universitätsarchiv Freiburg [Bildnr. UAF C 0197_11747]).

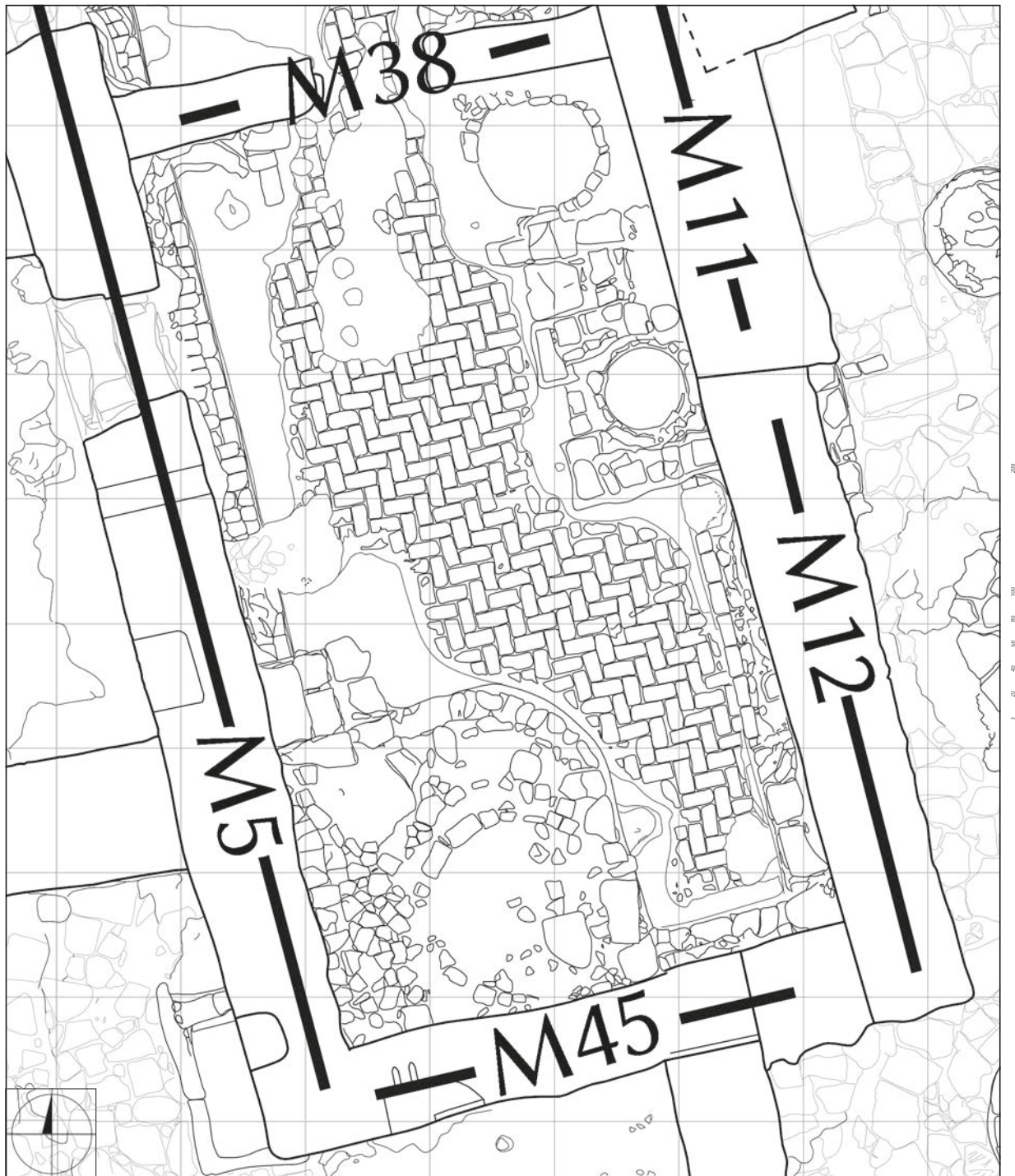

OT_84. Grundrisszeichnung. – (Plan K. Czarnitzki/S. Olschok).



a



b

OT_84. a Blick nach N. – b Blick nach S. – (a Foto R. Bodenstern; b Foto S. Olschok).



a



b

Nachträglich zugesetzte Tür im S von OT_84. **a** Blick nach S. – **b** Detailaufnahme der Türschwelle. – (Fotos S. Olschok).



a



b



c

OT_84. a Blick nach SO. – b Ofenplattform. Blick nach SW. – c Ofeninstallation. Blick nach O. – (Fotos S. Olschok).

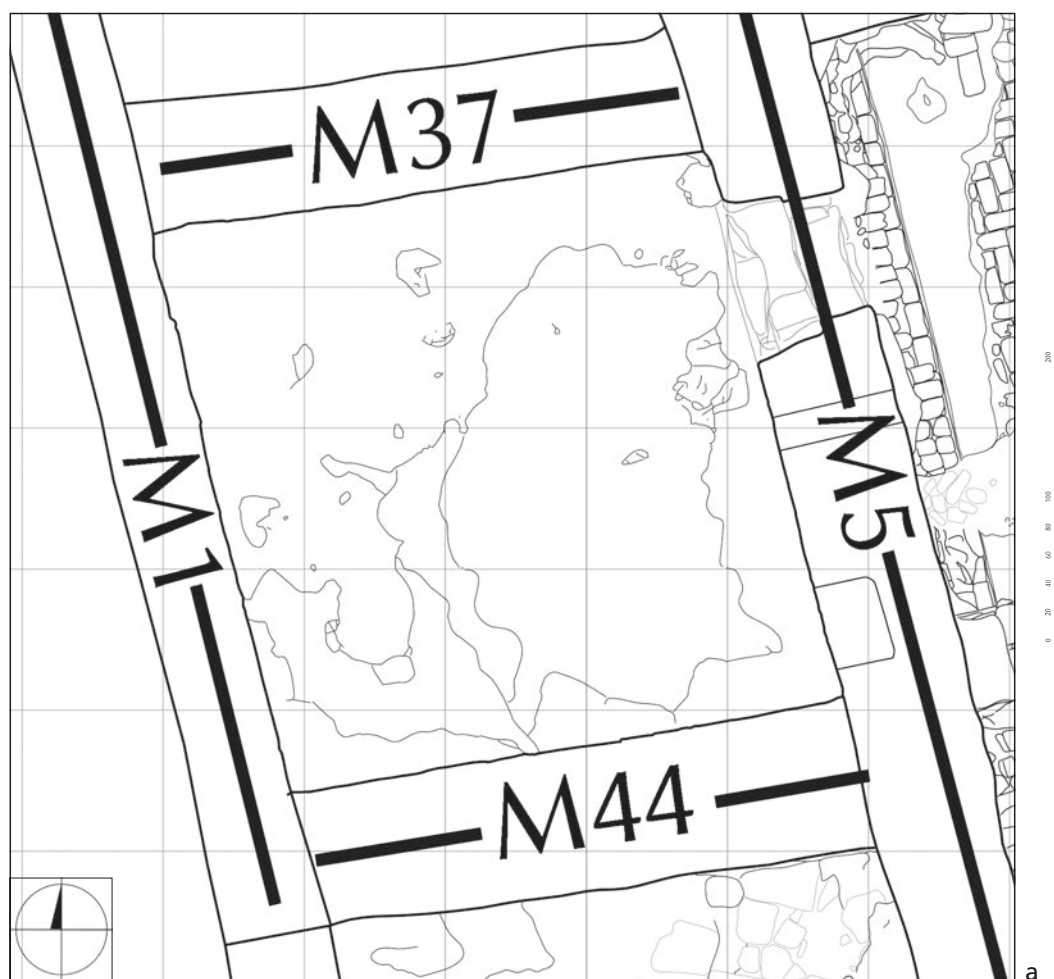

OT_85. a Grundrisszeichnung. – b Blick nach W. – (a Plan K. Czarnitzki/S. Olschok; b Foto R. Bodenstern).



OT_86. a Grundrisszeichnung. – b Blick nach O. – c Blick nach W. – (a Plan K. Czarnitzki/S. Olschok; b-c Fotos R. Bodenstern).



a



b



c



d

OT_86. a Tür und Fenster in M36. Blick nach S. – b Türdetail. Blick nach N. – c westliches Fenster. Blick nach N. – d östliches Fenster. Blick nach N. – (Fotos S. Olschok).

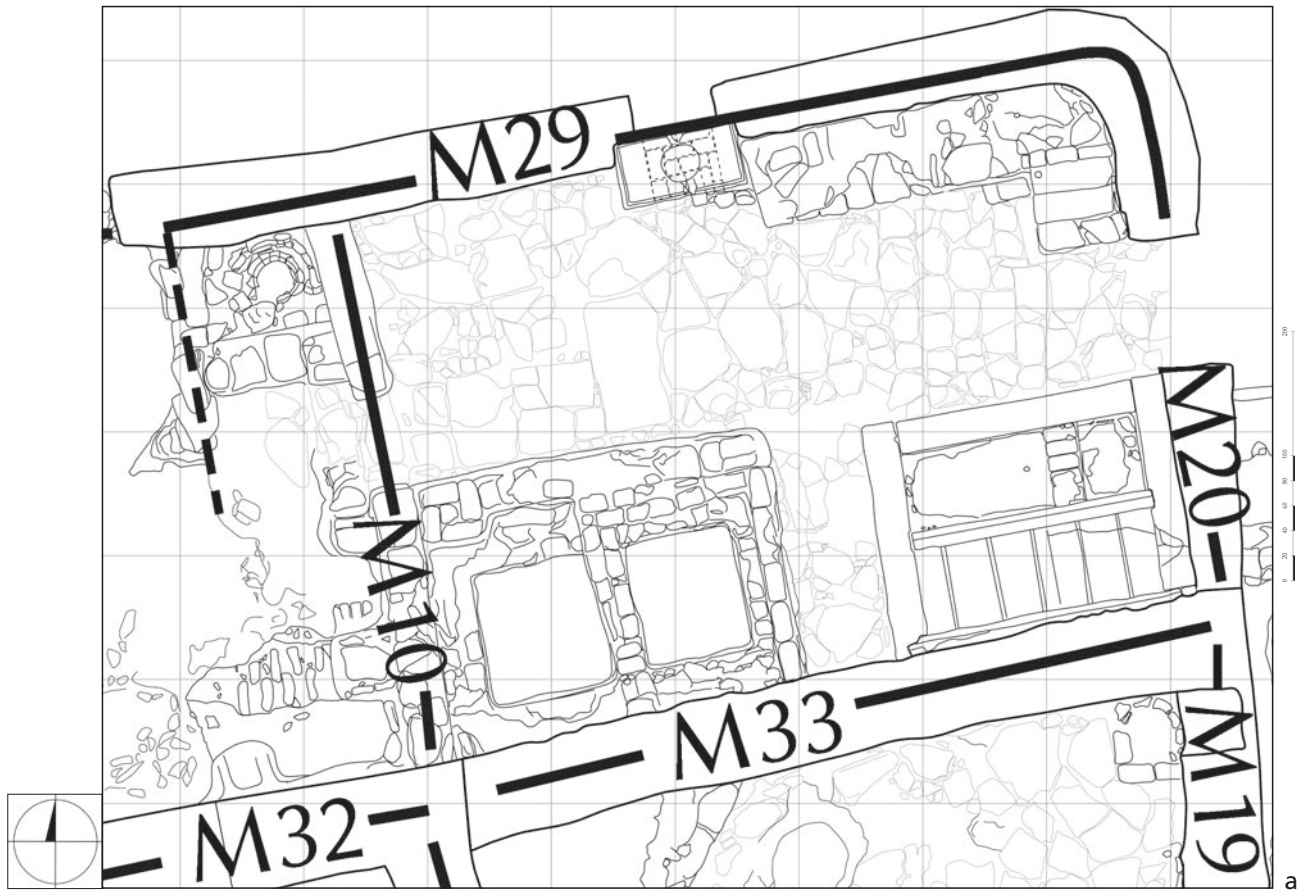

OT_87. a Grundrisszeichnung. – b Blick nach O. – (a Plan K. Czarnitzki/S. Olschok; b Foto R. Bodenstern).



a



b



c

OT_87. a Blick nach N. – b Blick von außen nach S. – c Blick nach W. – (a-b Fotos S. Olschok; c Foto R. Bodenstein).



a



b

OT_87. **a** Weinkelter. Blick nach S. – **b** Garumbecken. Blick nach SW. – (Fotos R. Bodenstern).



a

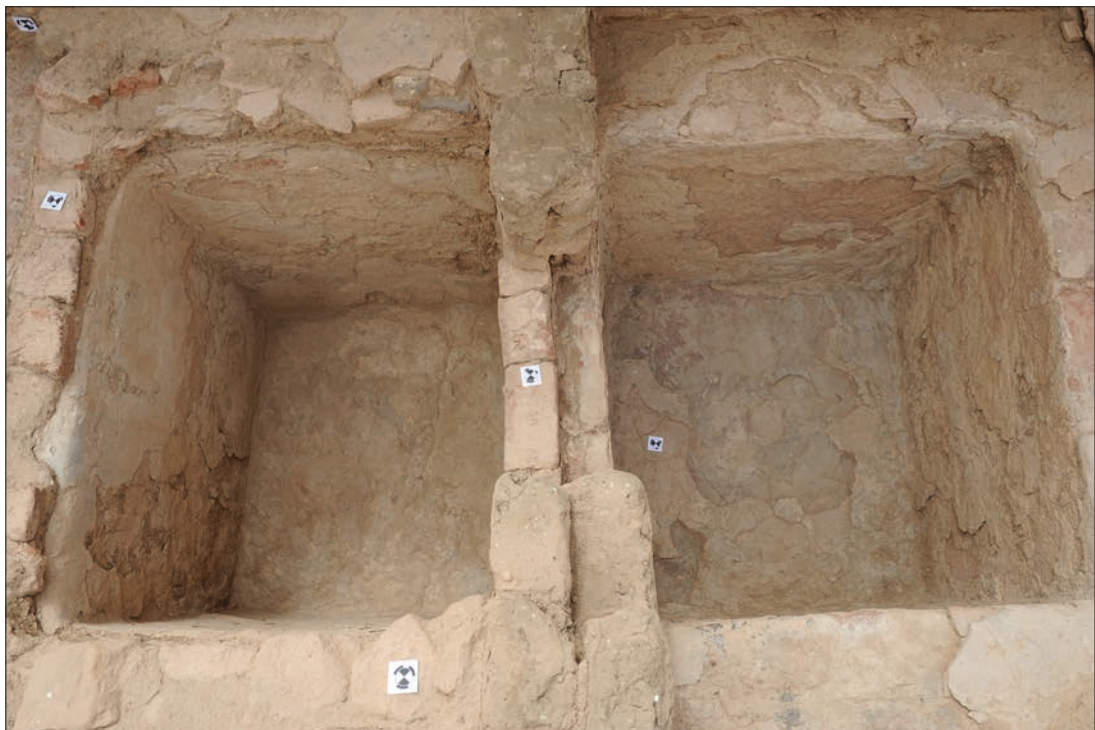

b

OT_87. Garumbecken. **a** Detailansicht der Trennmur und Bauphasen. Blick nach NO. – **b** Draufsicht. – (Fotos S. Olschok).

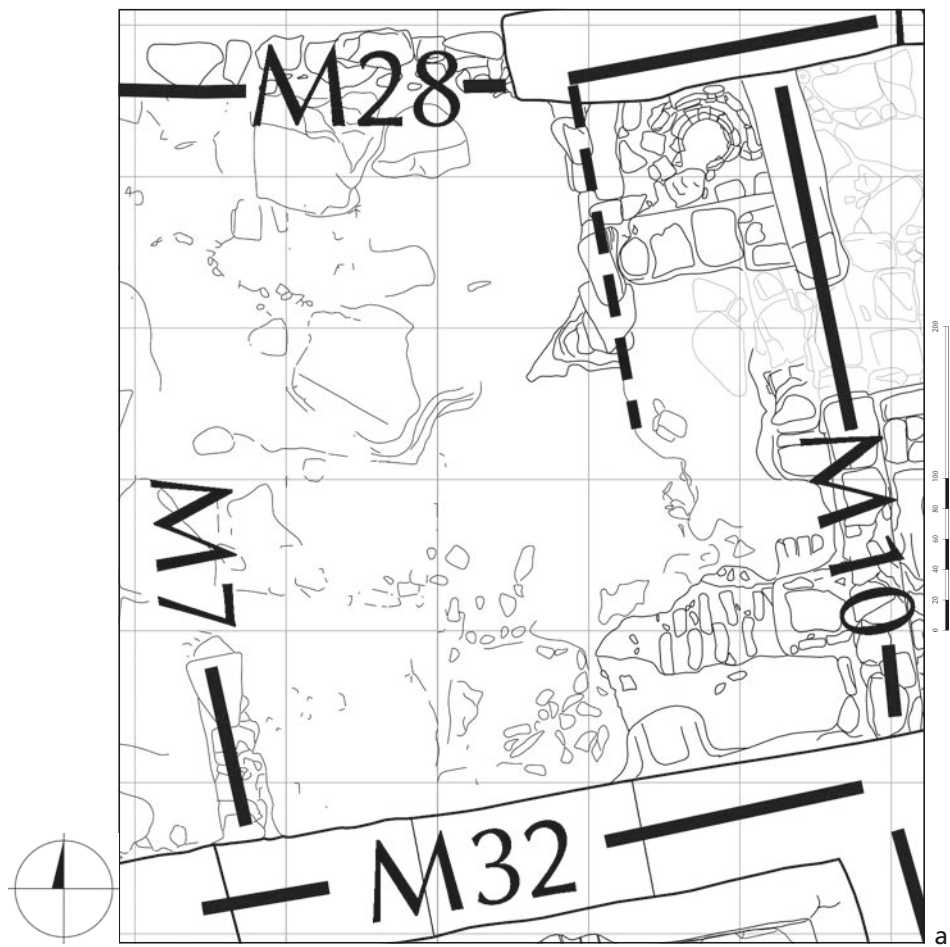

a OT_88. Grundrisszeichnung. – b Detailansicht des Podestes in OT_88. Blick nach NO. – c OT_88-90. Blick nach SO. –
(a Plan K. Czarnitzki/S. Olschok; b-c Fotos S. Olschok).

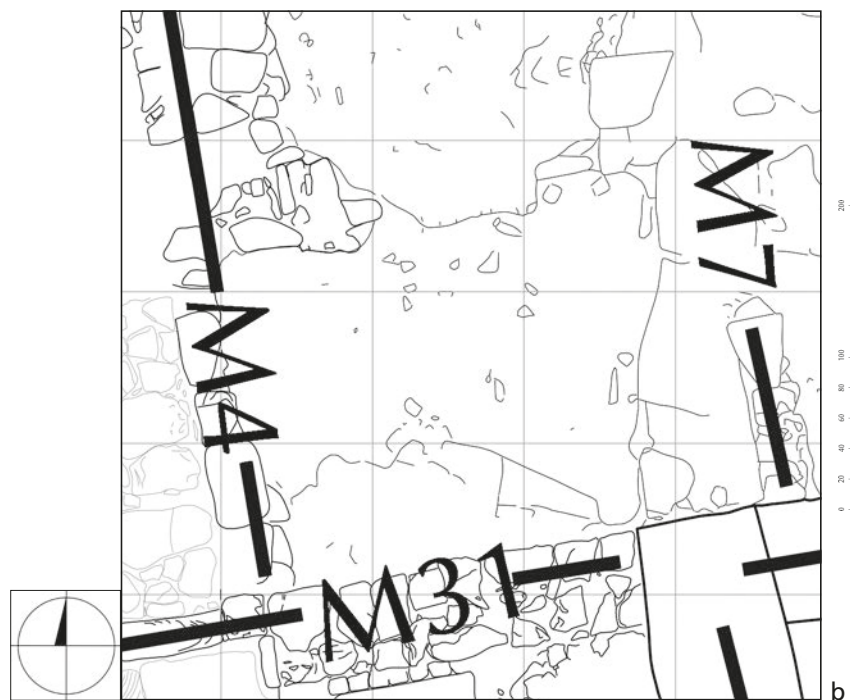
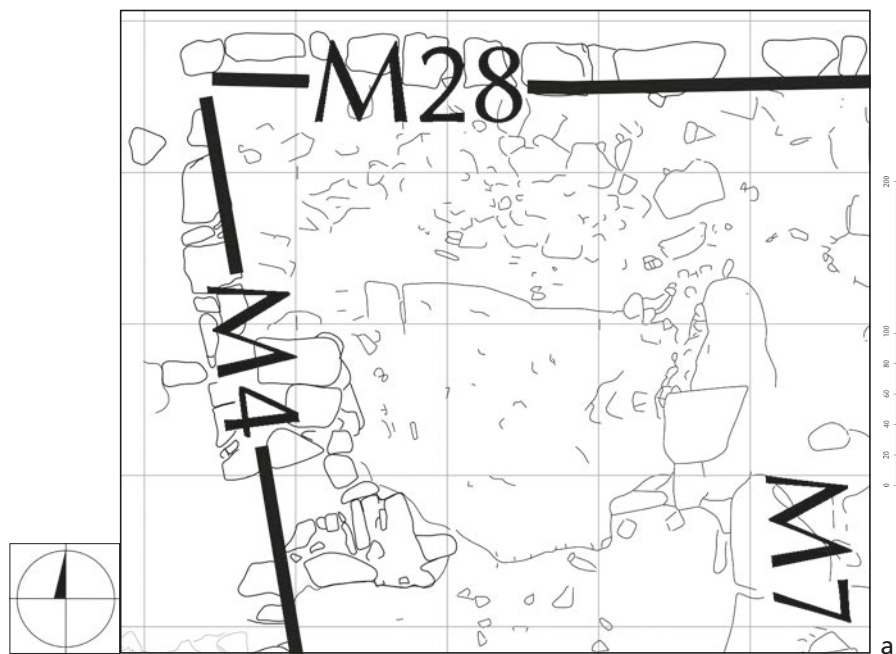

Grundrisszeichnung. a OT_89. – b OT_90. – (Pläne K. Czarnitzki/S. Olschok).

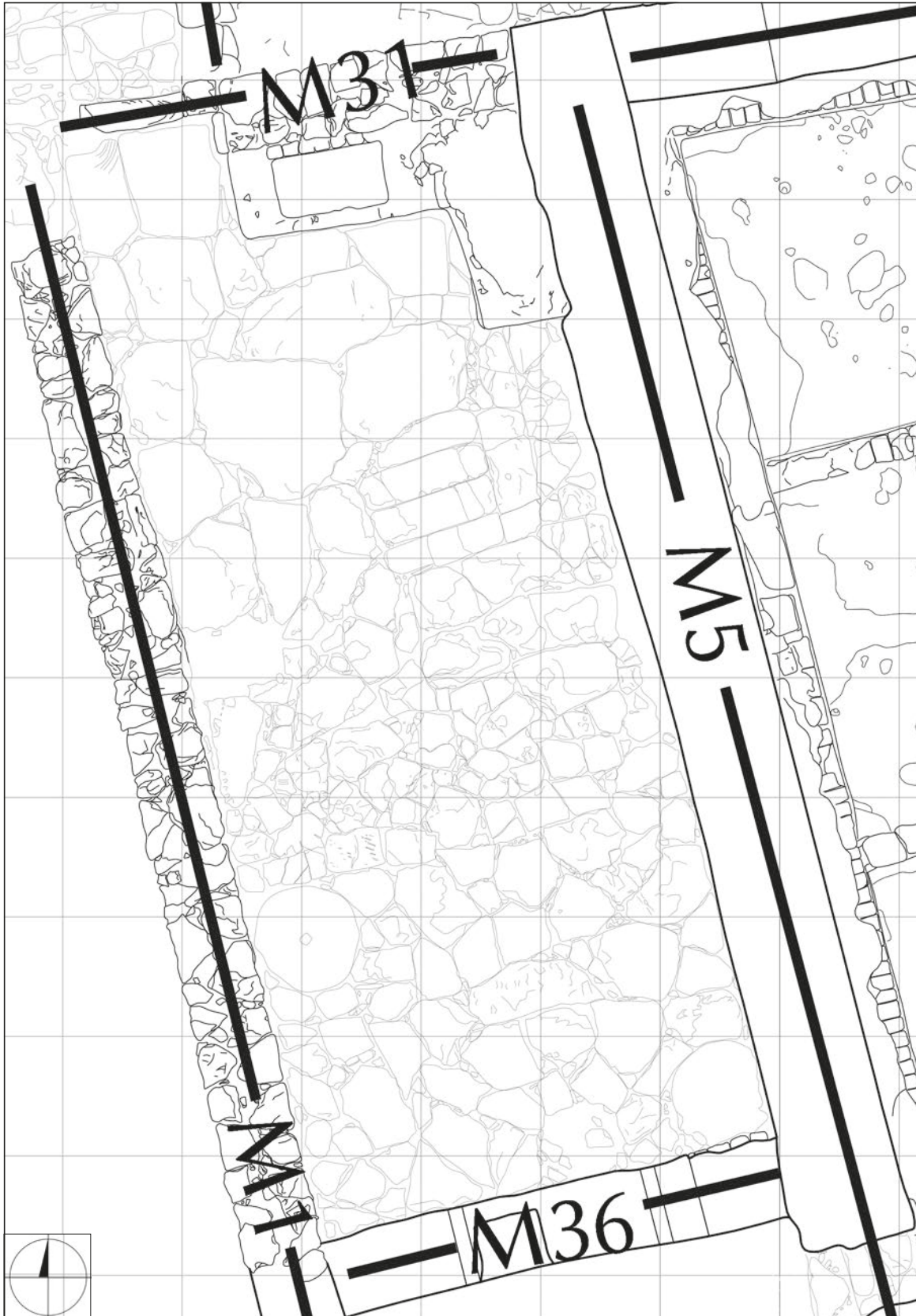



a



b



c

OT_91. a Übersicht. Blick nach SO. – b Detail der nördlichen Tür. – c Betteninstallation. Blick nach NO. – (Fotos S. Olschok).

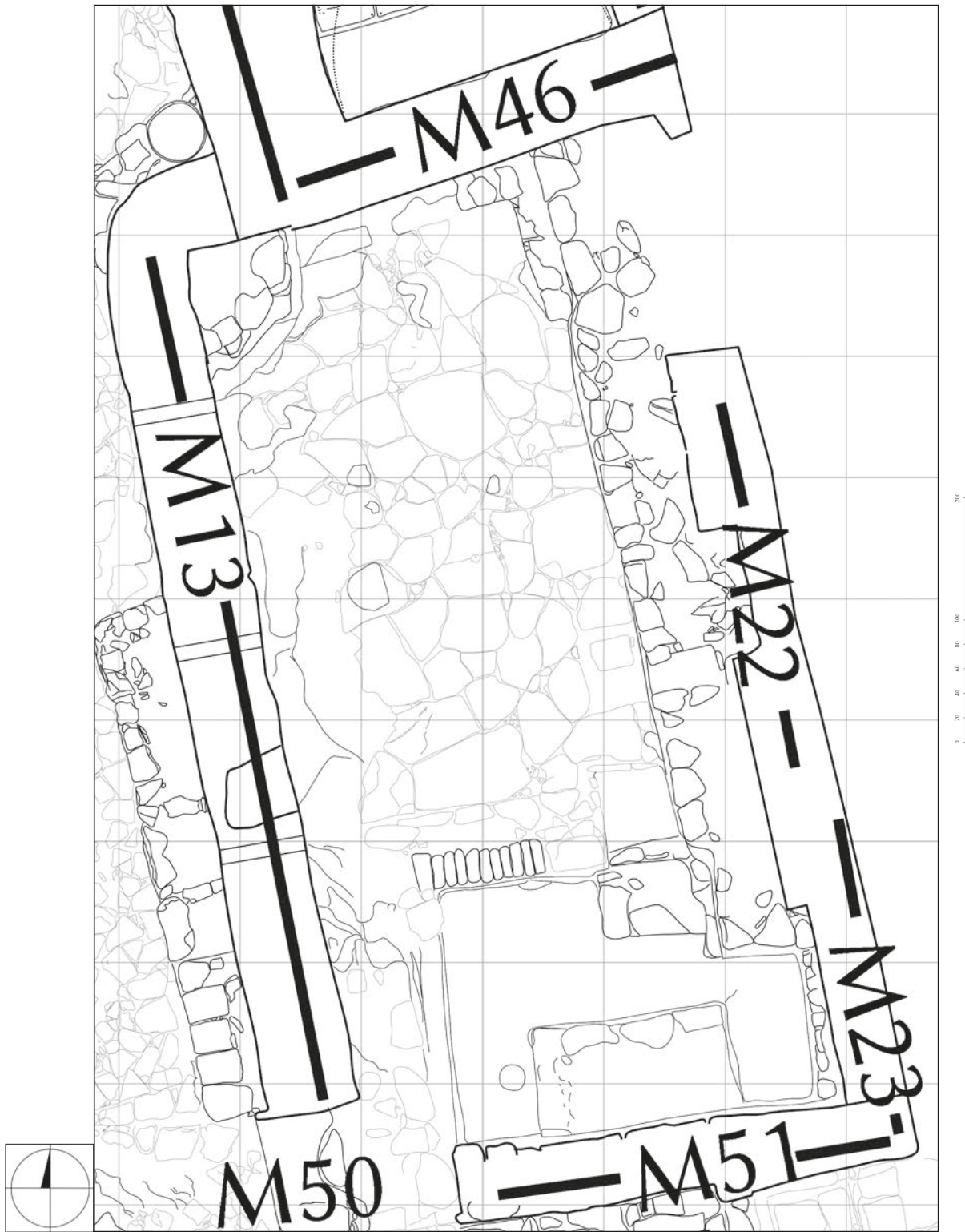



a



b

OT_92. **a** Blick nach S. – **b** Blick nach N. – (a Foto S. Lutz; b Foto R. Bodenstern).



a



b



d



c

OT_92. a Türschwelle im NO. – b Tür im S. Blick nach S. – c W-Wand. Blick nach W. – d Beckeninstallation. Blick nach O. – (Fotos S. Olschok).

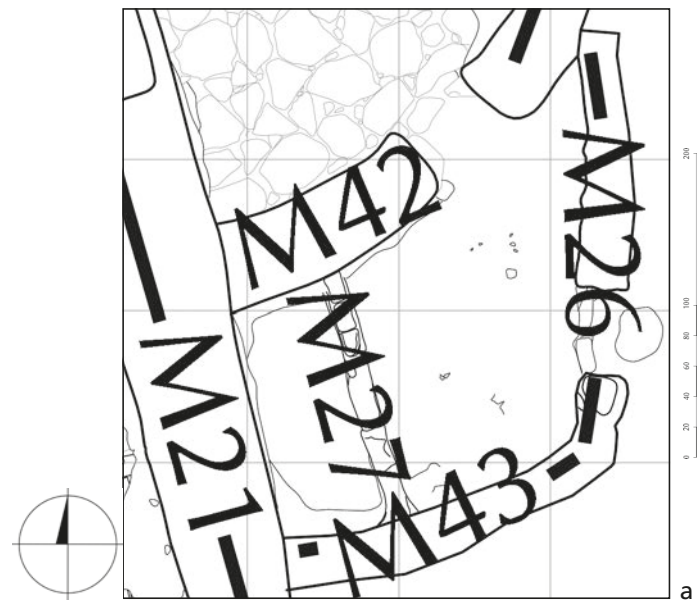

OT_149. a Grundrisszeichnung. – b Blick nach W. – (a Plan K. Czarnitzki/S. Olschok; b Foto S. Olschok).

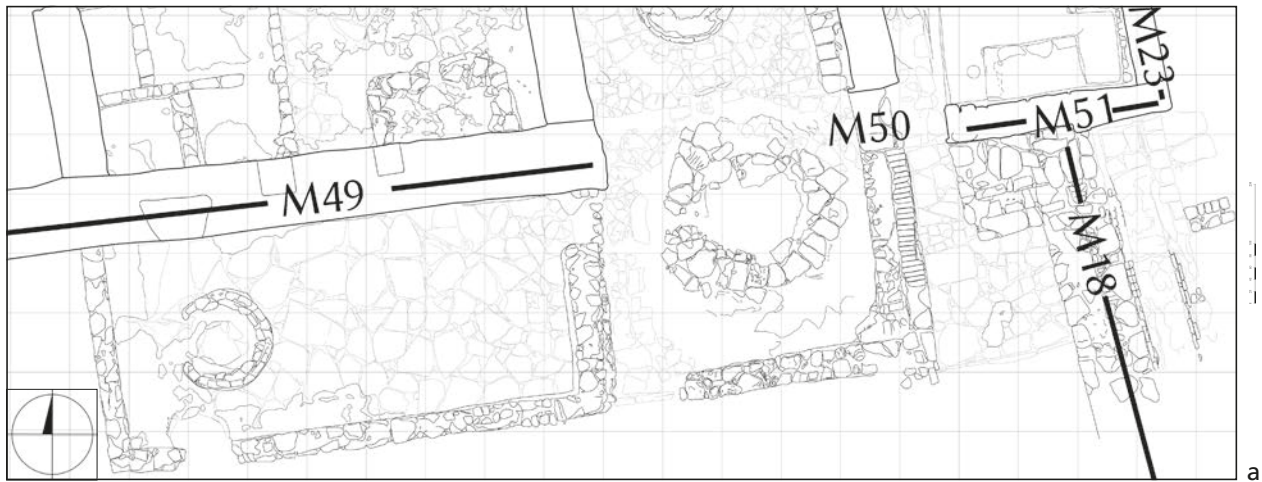

Klosterumfassungsmauer. **a** Grundrisszeichnung. – **b** Baufuge in der westlichen Umfassungsmauer. Blick nach O. – **c** Baufuge in der südlichen Umfassungsmauer. Blick nach SO. – **d** Baufuge in der südlichen Umfassungsmauer. Blick nach NW. – (a Plan K. Czarnitzki/S. Olschok; b-d Fotos S. Olschok).

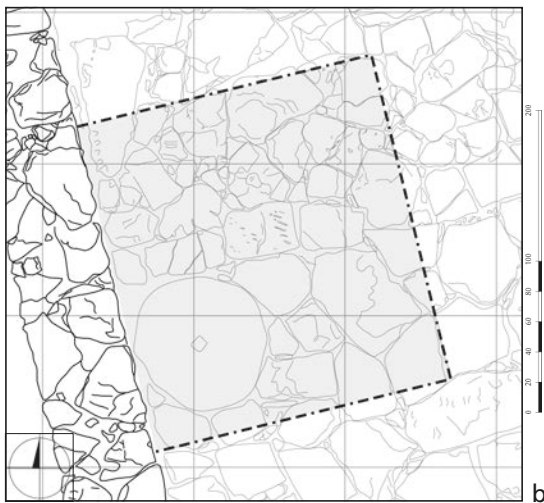
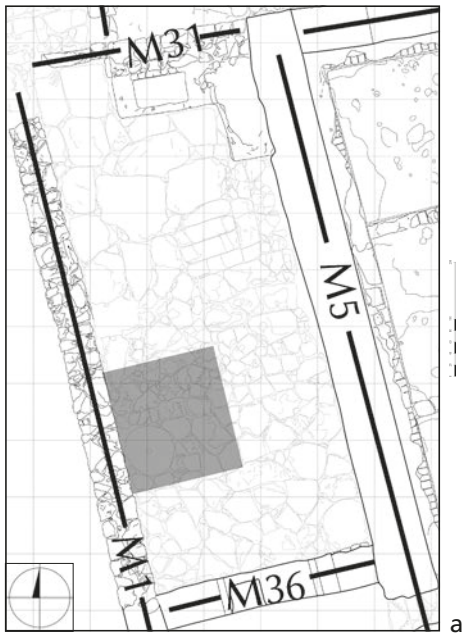

Schnitt 1. **a** Lokalisierung des Schnittes in OT_91. – **b** Zeichnung der Oberfläche. – **c** Oberfläche (Bef. 1-2). – **d** Lehmfußboden (Bef. 6. 10). – **e** anstehender Fels (Bef. 14). – (a-b Pläne K. Czarnitzki/S. Olschok; c-d Fotos H. Sonbol; e Foto S. Olschok).

▽132,50

▽132,00

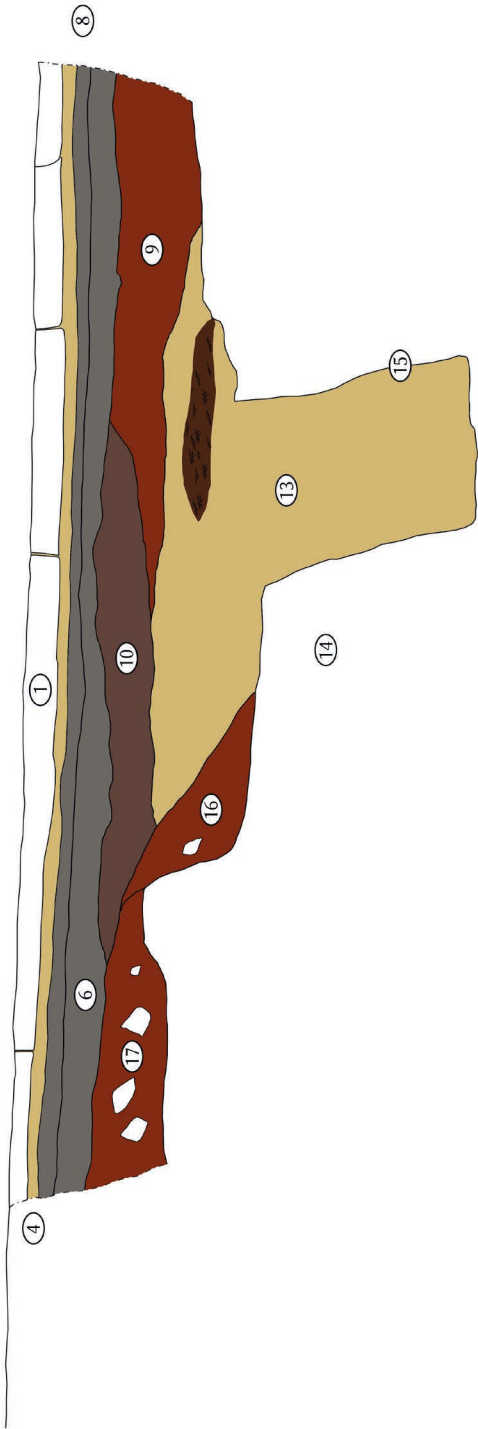

- Sand
- Lehm
- Lehm
- Schnittkante
- Stein
- Pflanzenreste
- Splitt/Schotter



a

b

Schnitt 1. Profil 1. Blick nach N. a Zeichnung. – b Foto. – (Zeichnung/Foto S. Olschok).

▽132,50

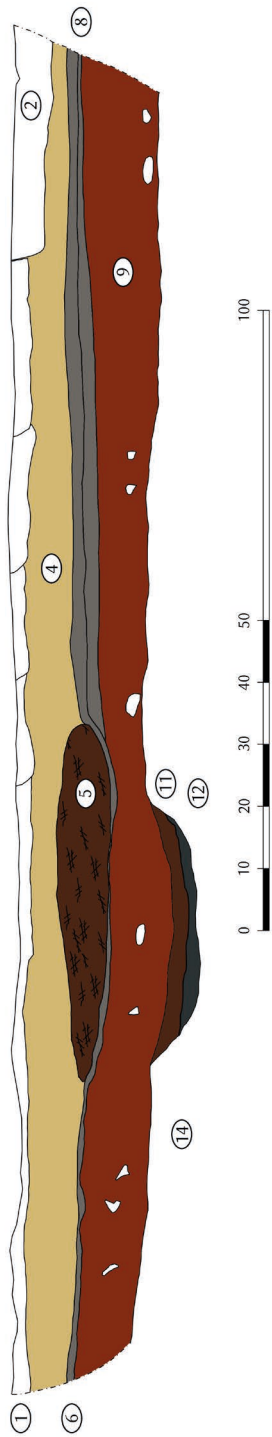

a

- Schnittkante
- Stein
- Pflanzenreste
- Splitt/Schotter
- Sand
- Lehm
- Asche



b

Schnitt 1. Profil 2. Blick nach O. a Zeichnung. – b Foto. – (Zeichnung/Foto S. Olschok).

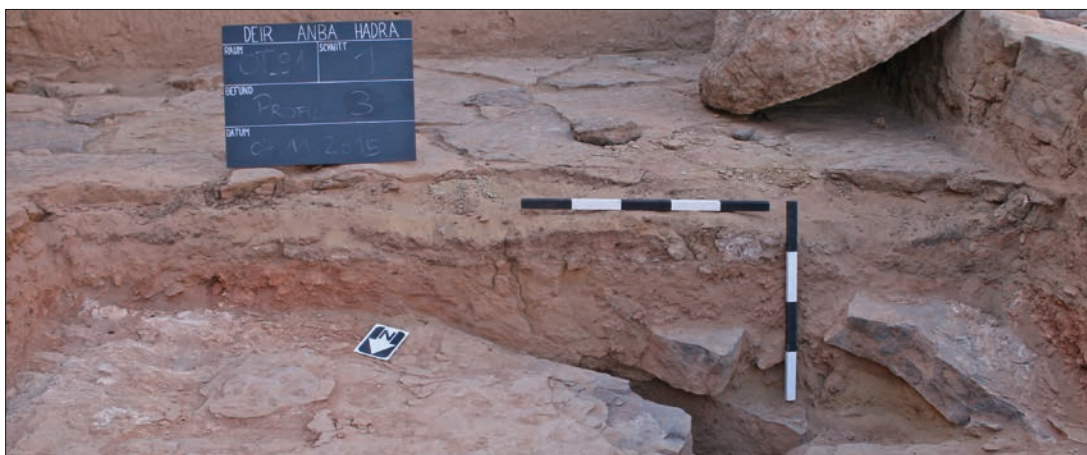
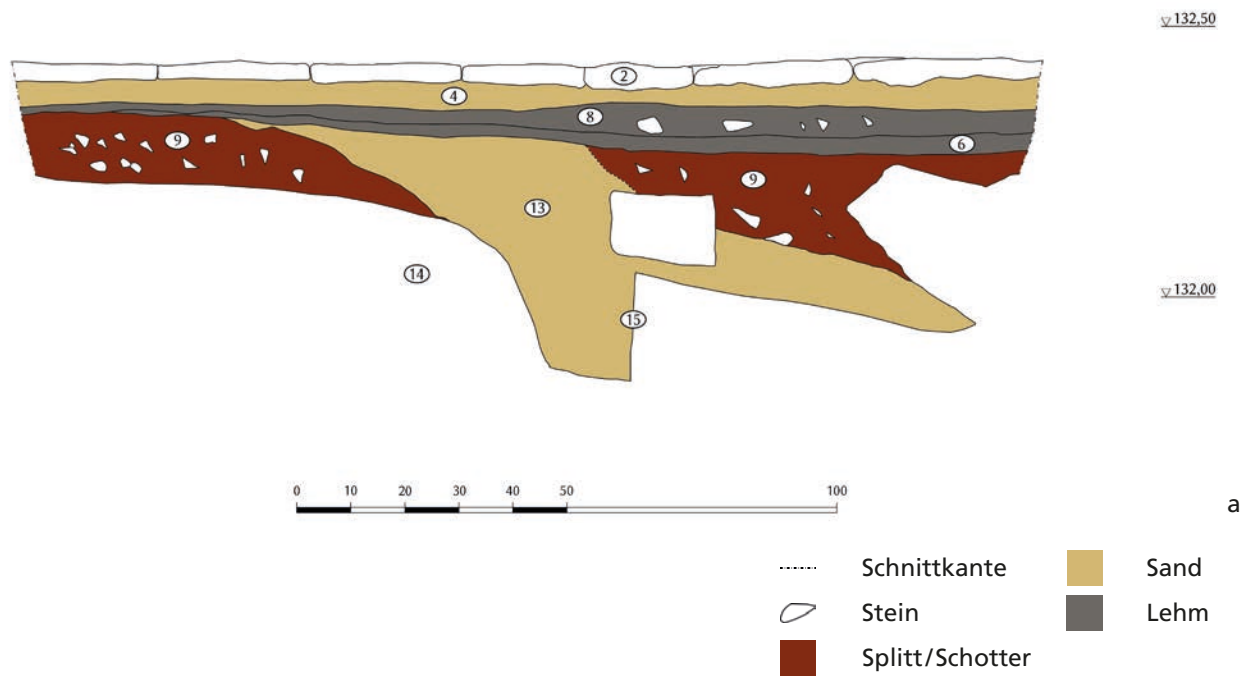

Schnitt 1. Profil 3. Blick nach S. **a** Zeichnung. – **b** Foto. – (Zeichnung/Foto S. Olschok).

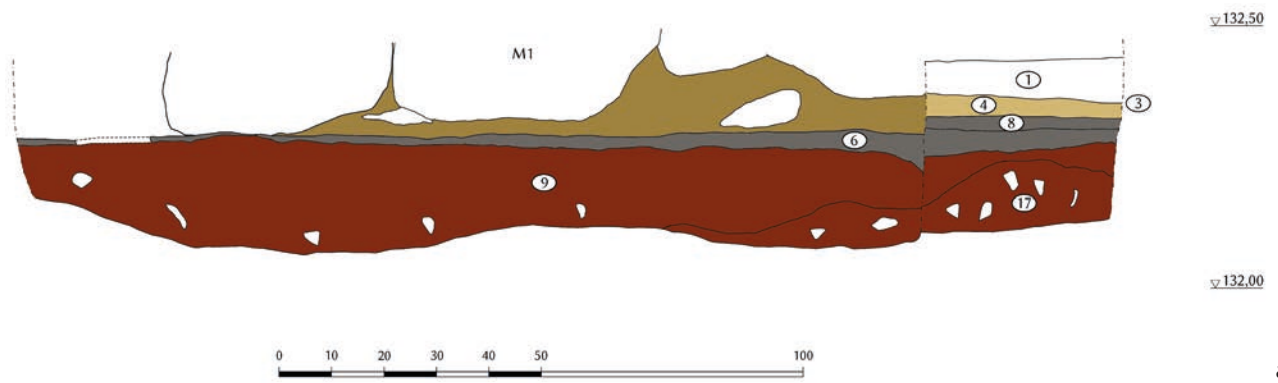

a

- | | | | |
|-------|-----------------|--|------|
| ----- | Schnittkante | | Sand |
| | Stein | | Lehm |
| | Splitt/Schotter | | Lehm |



b

Schnitt 1. Profil 4. Blick nach W. **a** Zeichnung. – **b** Foto. – (Zeichnung/Foto S. Olschok).

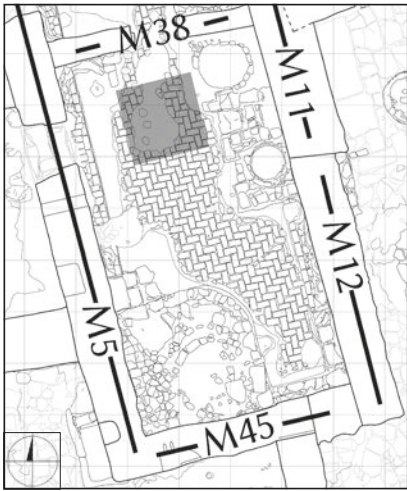

Schnitt 2. **a** Lokalisierung des Schnittes in OT_84. – **b** Zeichnung der Oberfläche. – **c** Fußboden mit darunter liegenden Schichten (Bef. 19-22). – **d** anstehender Fels (Bef. 36). – (a-b Pläne K. Czarnitzki/S. Olschok; c-d Fotos H. Sonbol).



a

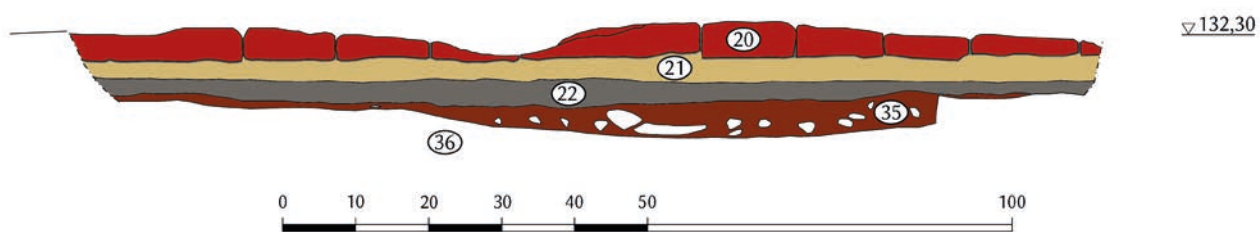

b

- | | | | |
|---|--------------|---|-----------------|
| | Schnittkante |  | Sand |
|  | Stein |  | Asche |
|  | Ziegel |  | Splitt/Schotter |

Schnitt 2. Profil 5. Blick nach S. **a** Zeichnung. – **b** Foto. – (Zeichnung/Foto S. Olschok).

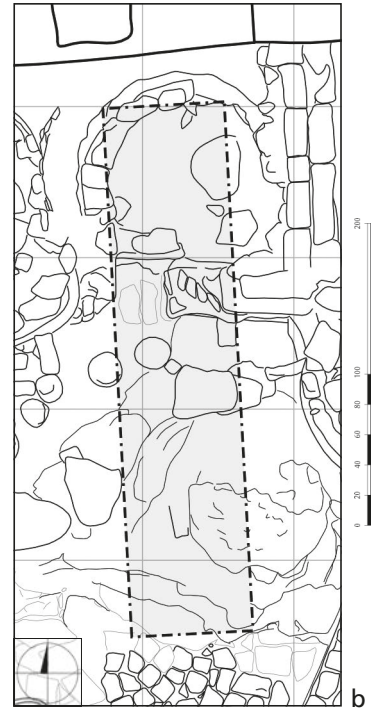

Schnitt 3. **a** Lokalisierung des Schnittes in OT_78. – **b** Zeichnung der Oberfläche. – **c** Oberfläche (Bef. 37-38. 81. 105-106. 122). – **d** Ofen-/Feuerstelle (Bef. 44). – **e** Negativbefund der Ofen-/Feuerstelle (Bef. 66). – (a-b Pläne K. Czarnitzki/S. Olschok; c-e Fotos H. Sonbol).



a



b

Schnitt 3. **a** Mattendetail (Bef. 61). – **b** Steinfußboden (Bef. 95). – (Fotos H. Sonbol).

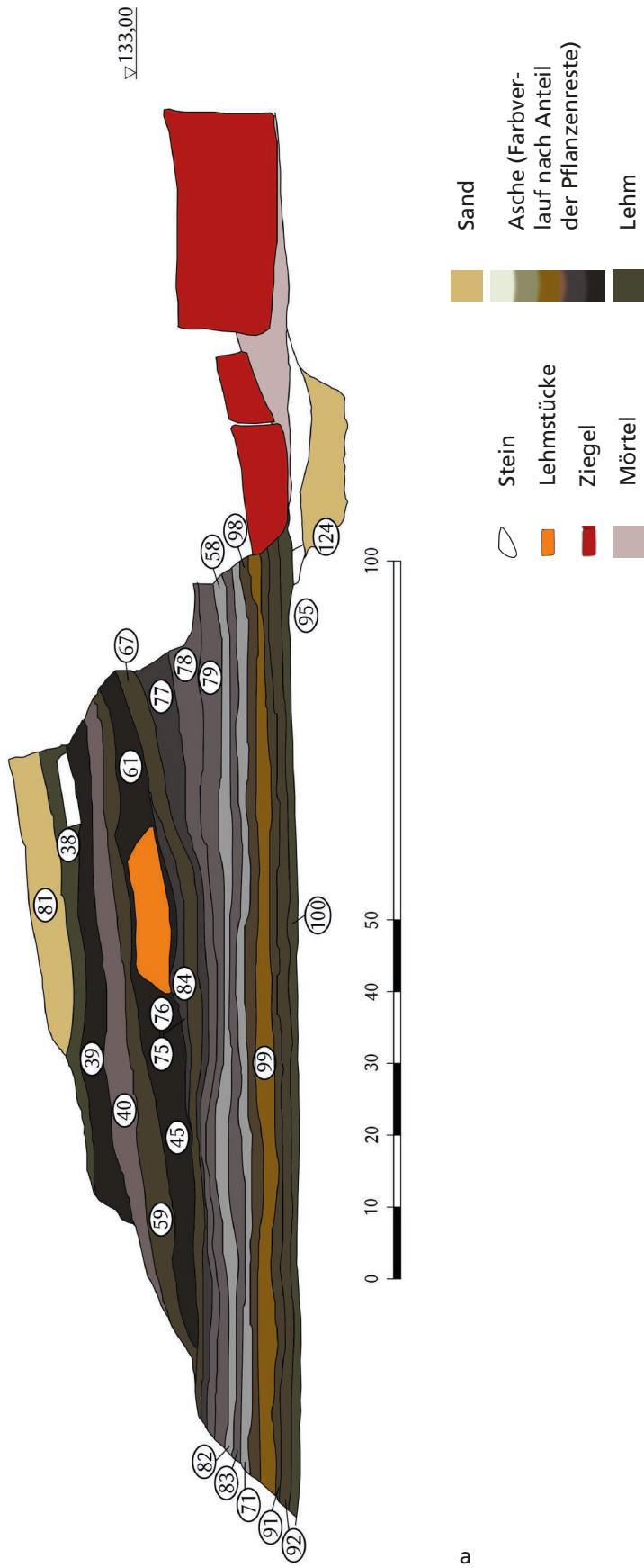

a



b

Schnitt 3. Profil 11. Blick nach S. **a** Zeichnung. – **b** Foto. – (a Zeichnung F. Allam; b Foto S. Olschok).

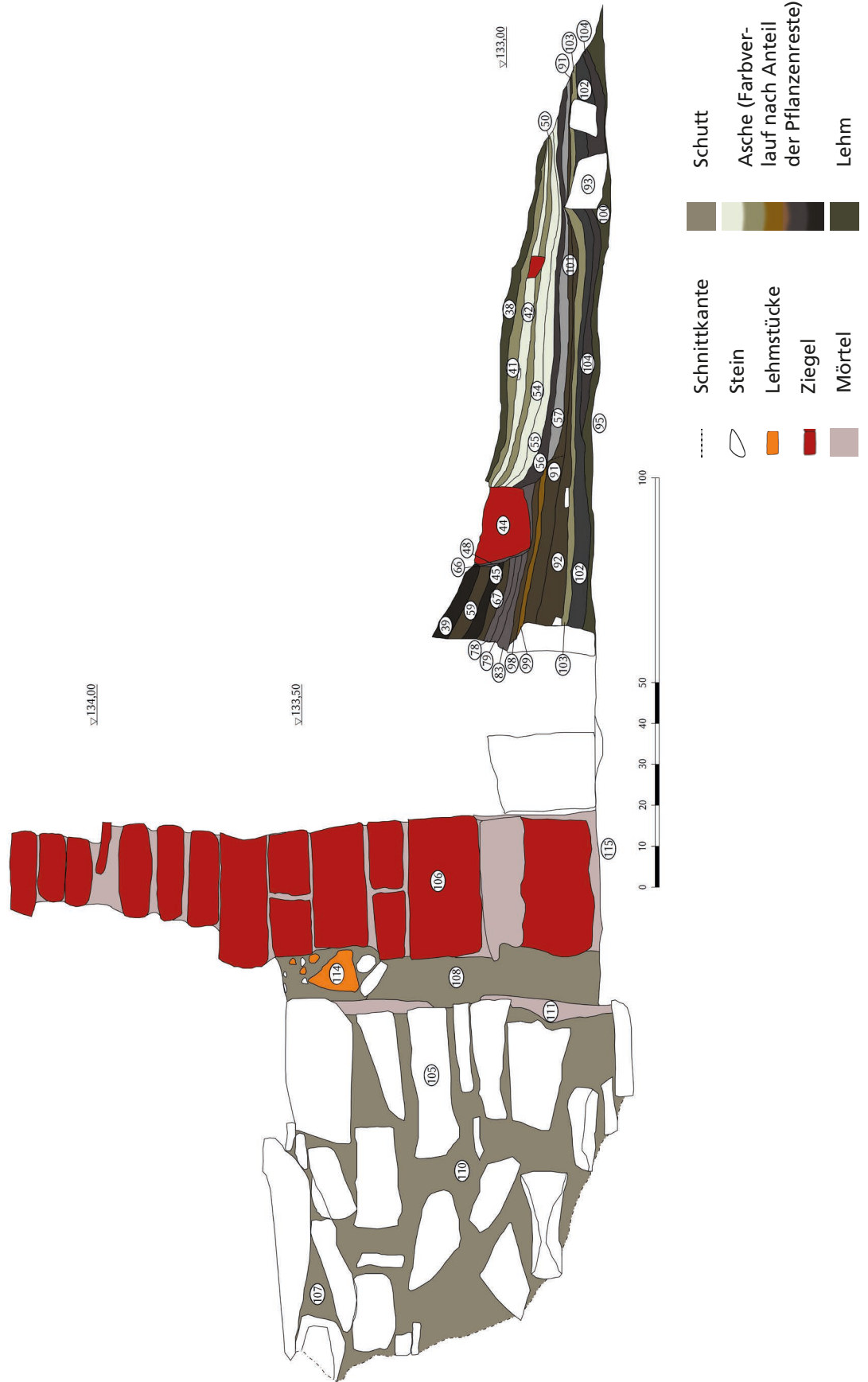

Schnitt 3. Profil 12. Blick nach N. Zeichnung. – (Zeichnung F. Allam).



Schnitt 3. Profil 12. Blick nach N. **a** Foto. W-Teil. – **b** Foto. Mittel-Teil. – **c** Foto. O-Teil. – (Fotos S. Olschok).

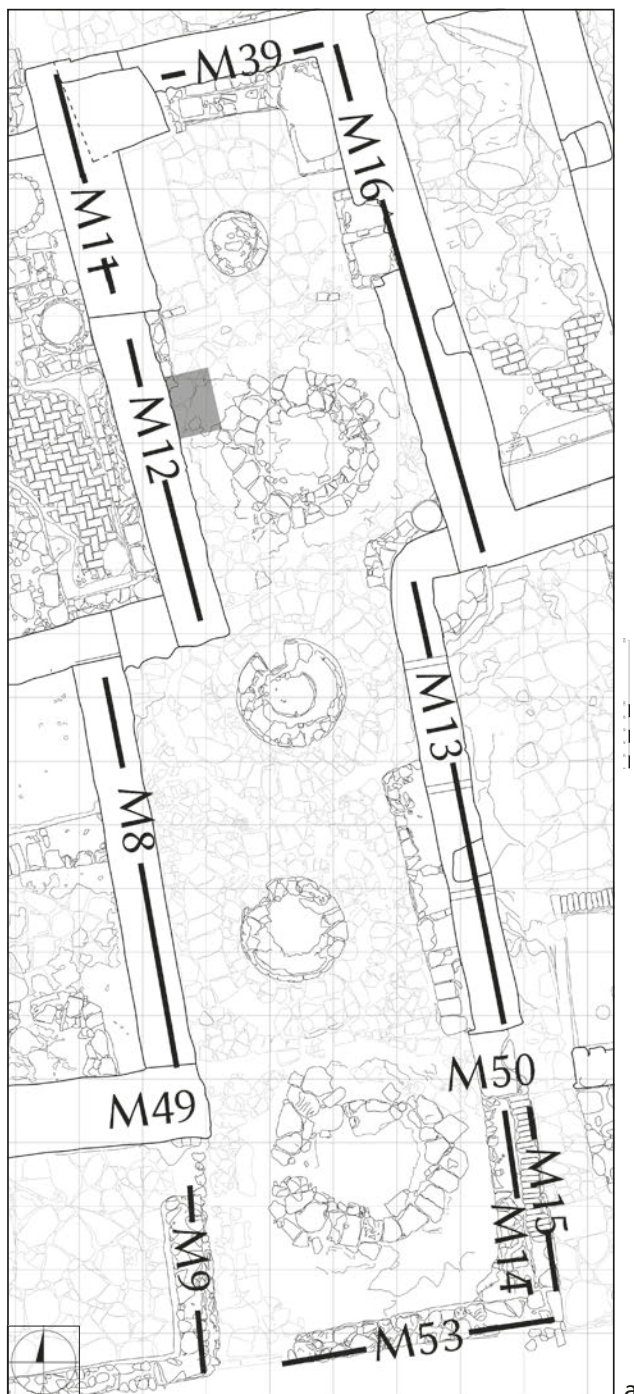

Schnitt 4. **a** Lokalisierung des Schnittes in OT_74. – **b** Zeichnung der Oberfläche. – **c** Oberfläche (Bef. 43. 46). – (a-b Pläne K. Czarnitzki/S. Olschok; c Foto S. Olschok).

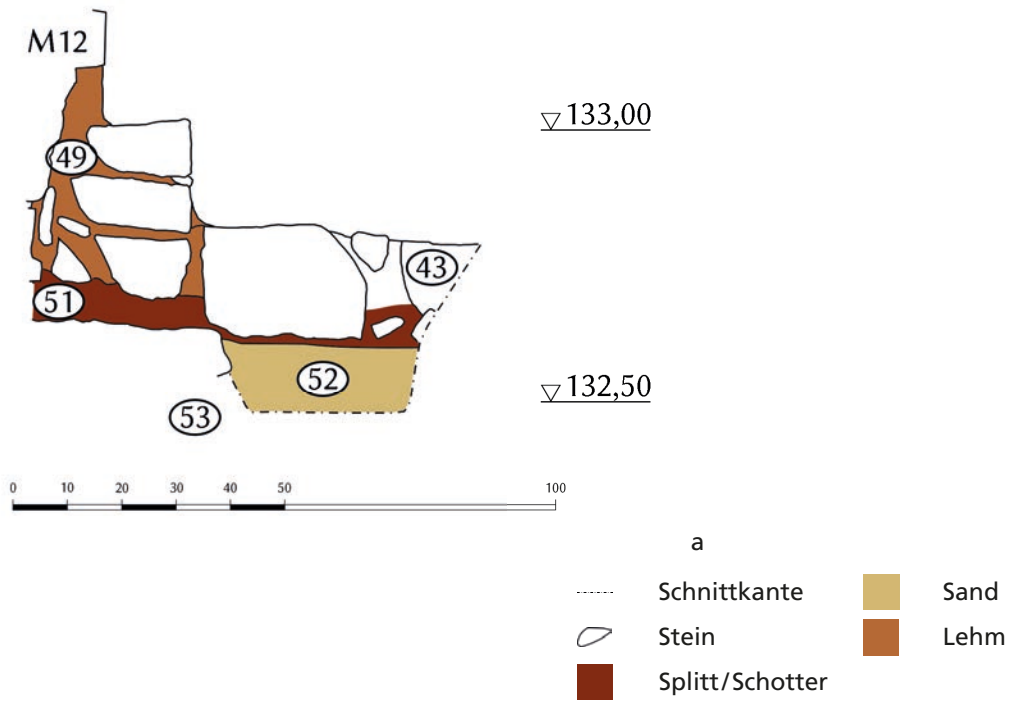

Schnitt 4. Profil 7. Blick nach N. a Zeichnung. – b Foto. – (Zeichnung/Foto S. Olschok).

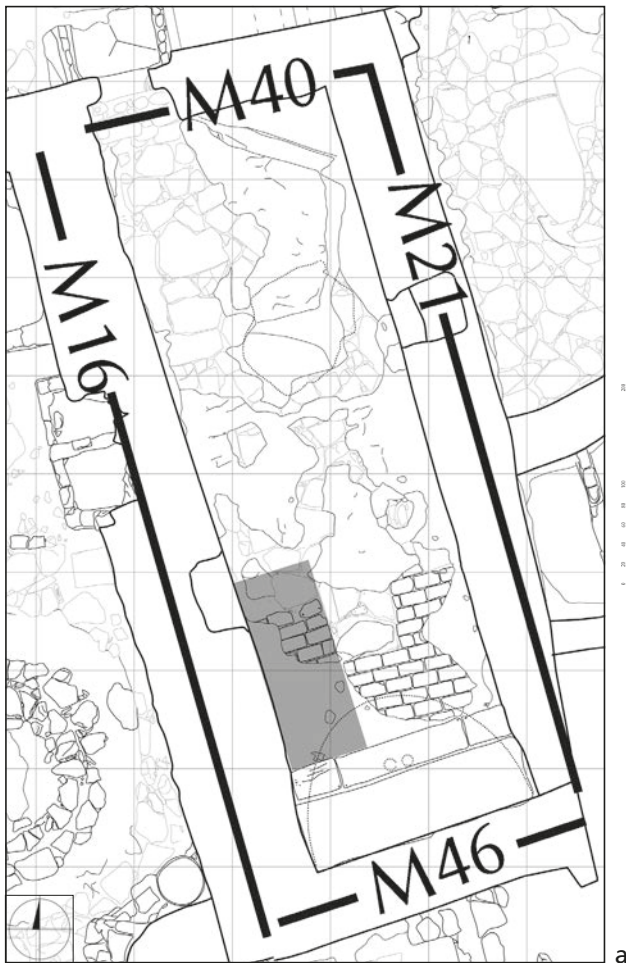

a

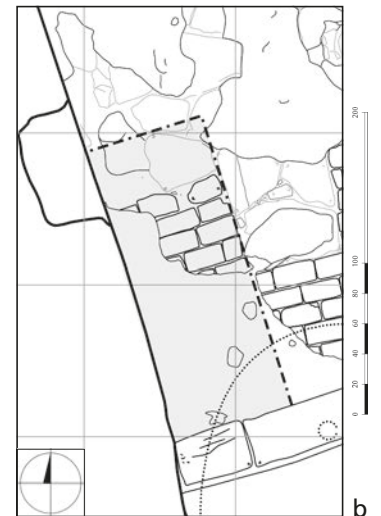

b



e



c



d



f

Schnitt 5. **a** Lokalisierung des Schnittes in OT_80. – **b** Zeichnung der Oberfläche. – **c** Oberfläche (Bef. 62-64). – **d** rechteckige Ausparung unter der Steinschwelle (Bef. 68-69). – **e** Detail der NW-Ecke. – **f** anstehender Fels (Bef. 80). – (a-b Pläne K. Czarnitzki/S. Olschok; c-f Fotos S. Olschok).

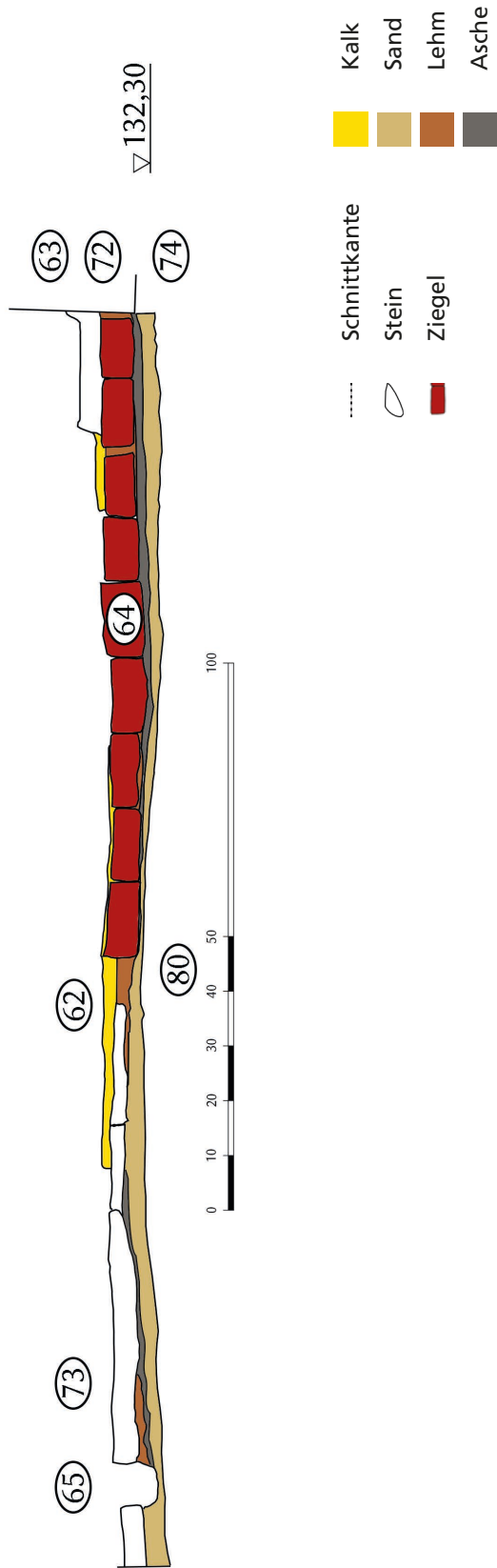

Schnitt 5. Profil 6. Zeichnung. Blick nach O. – (Zeichnung S. Olschok).



a



b

Schnitt 5. Profil 6. Blick nach O. **a** Foto. S-Teil. – **b** Foto. N-Teil. – (Fotos S. Olschok).



Schnitte 6 und 8. **a** Lokalisierung der Schnitte in OT_81. – **b** Zeichnung der Oberfläche. – **c** Oberfläche (Bef. 86-88. 125). Blick nach W. – **d** freigelegter Schnitt 6 (links), Oberfläche Schnitt 8 (Bef. 125; rechts). Blick nach S. – **e** vollständig freigelegte Installation (Bef. 87) und Ausbruchgrube (Bef. 97). Blick nach S. – (a-b Pläne K. Czarnitzki/S. Olschok; c-e Fotos S. Olschok).

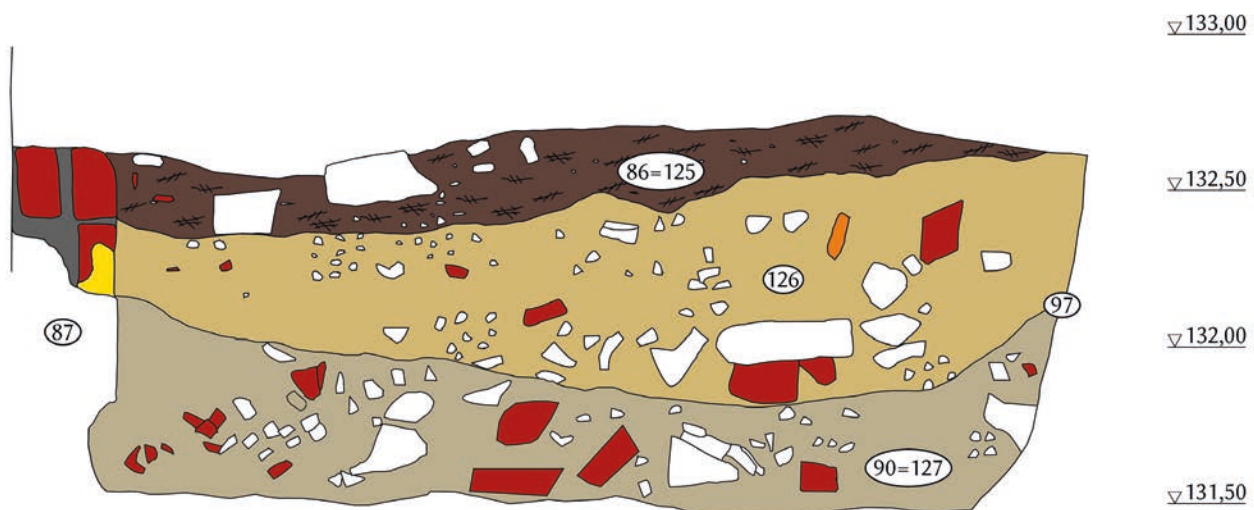

a

- | | | | |
|-------|---------------|---|--------|
| | Schnittkante | | Putz |
| | Stein | | Mörtel |
| | Lehmstücke | | Schutt |
| | Ziegel | | Schutt |
| | Pflanzenreste | | Schutt |



b

Schnitt 6. Profil 8. Blick nach W. a Zeichnung. – b Foto. – (Zeichnung/Foto S. Olschok).

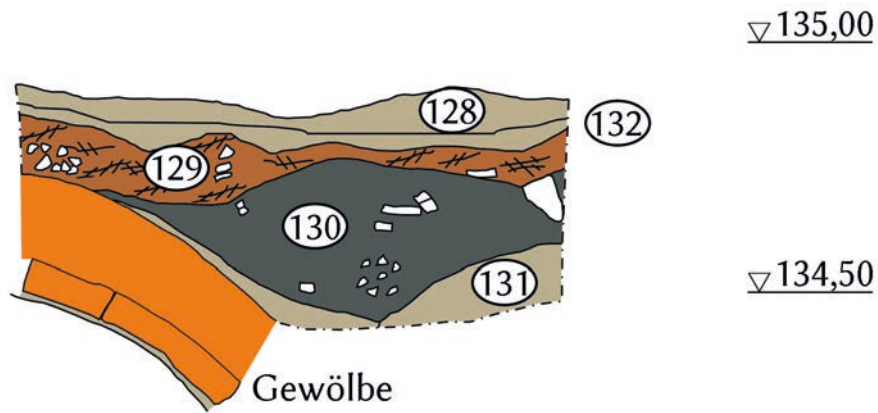
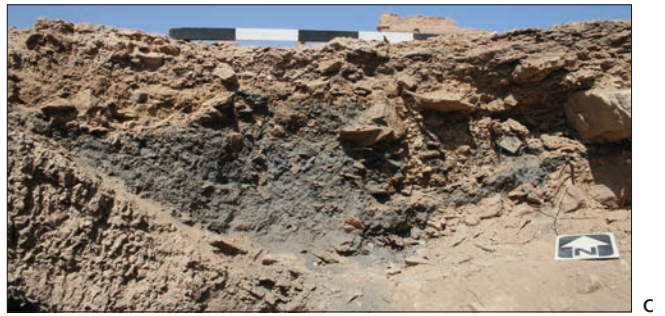
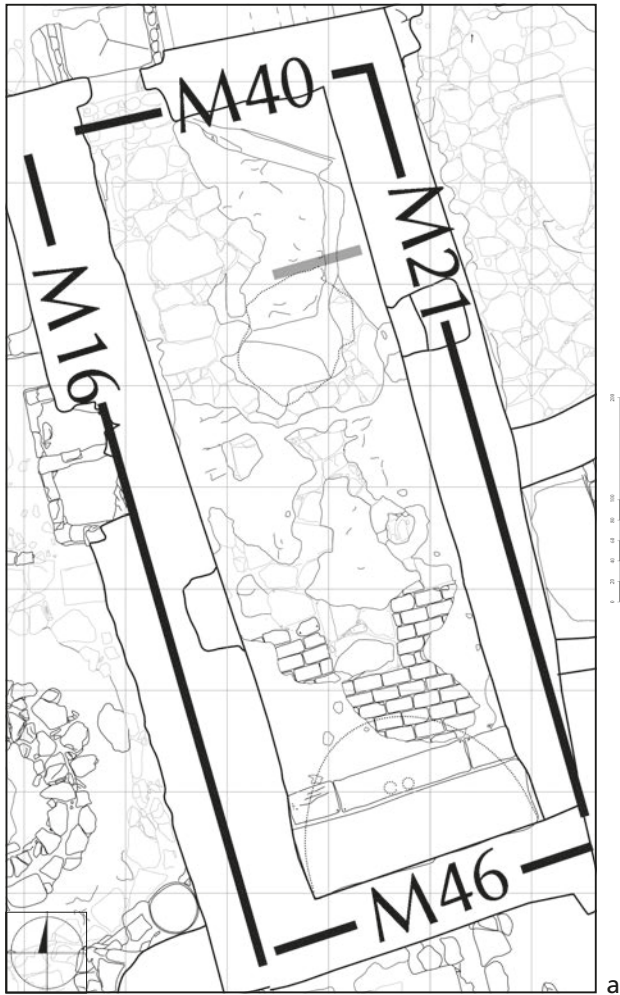

- d
- Schnittkante
 - Stein
 - Lehmziegel
 - Lehm
 - Pflanzenreste
 - Schutt

Schnitt 9. a Lokalisierung des Schnittes in OT_80. – b Zeichnung der Oberfläche. – c Profil 10. Zeichnung. – d Profil 10. Foto. – (a-b Pläne K. Czarnitzki/S. Olschok; c-d Zeichnung/Foto S. Olschok).

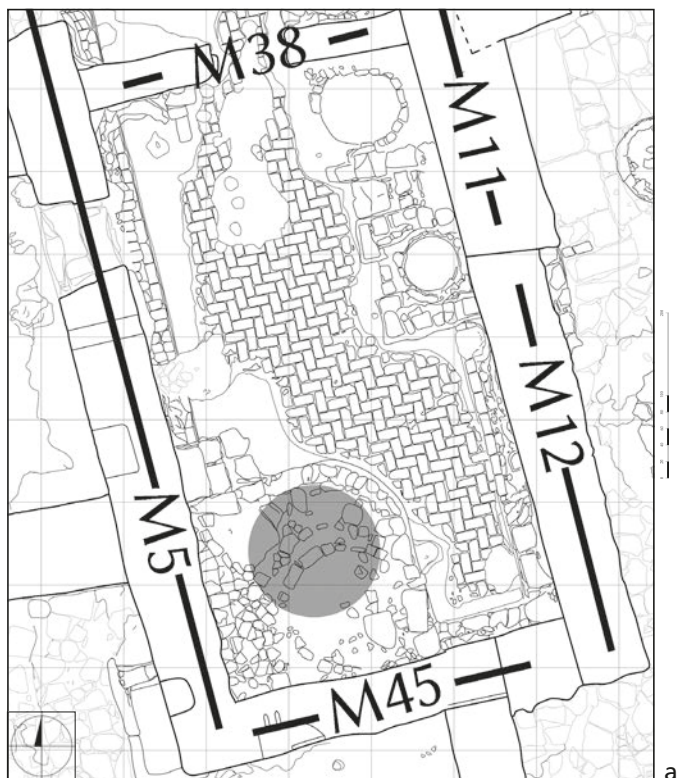

Schnitt 7. **a** Lokalisierung des Schnittes in OT_84. – **b** Zeichnung der Oberfläche. – **c** Ofeninnenraum mit Aschefüllung (Bef. 112. 119). Blick nach S. – **d** freigelegter Ofeninnenraum. Blick nach S. – (a-b Pläne K. Czarnitzki/S. Olschok; c-d Fotos S. Olschok).

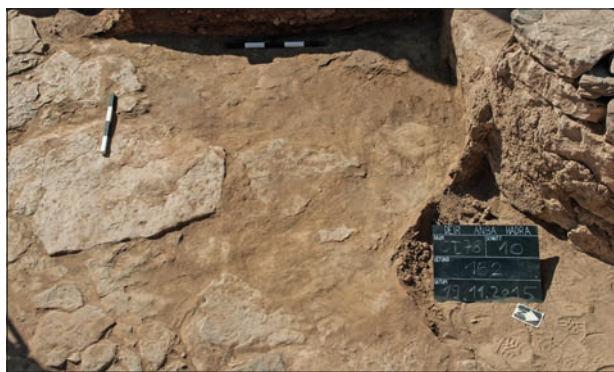
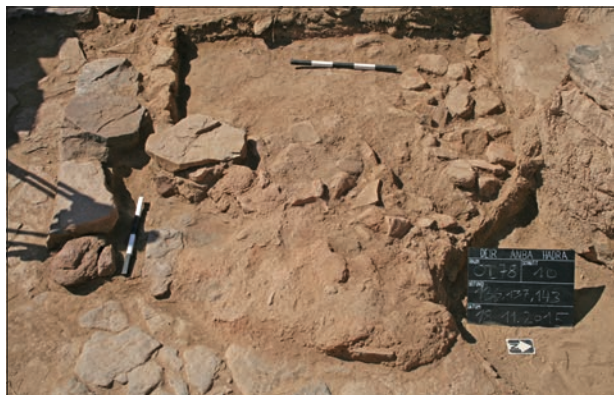

Schnitt 10. **a** Lokalisierung des Schnittes in OT_78. – **b** Zeichnung der Oberfläche. – **c** Oberfläche (Bef. 134-137. 140). – **d** Lehm-
 schicht über Versturzlage (Bef. 143). – **e** Versturz (Bef. 145). – **f** Fußboden (Bef. 152). – (a-b Pläne K. Czarnitzki/S. Olschok; c-f Fotos S. Olschok).

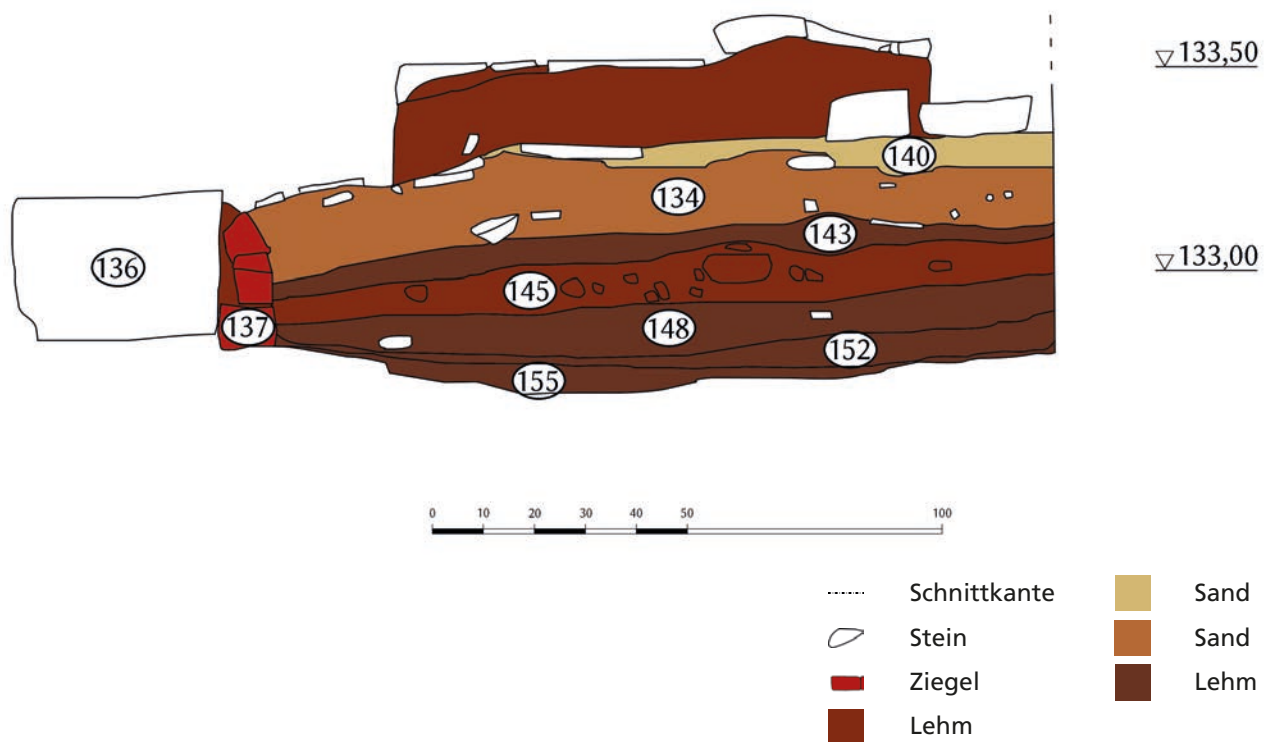

a



b

Schnitt 10. Profil 13. Blick nach W. **a** Zeichnung. – **b** Foto. – (Zeichnung/Foto S. Olschok).

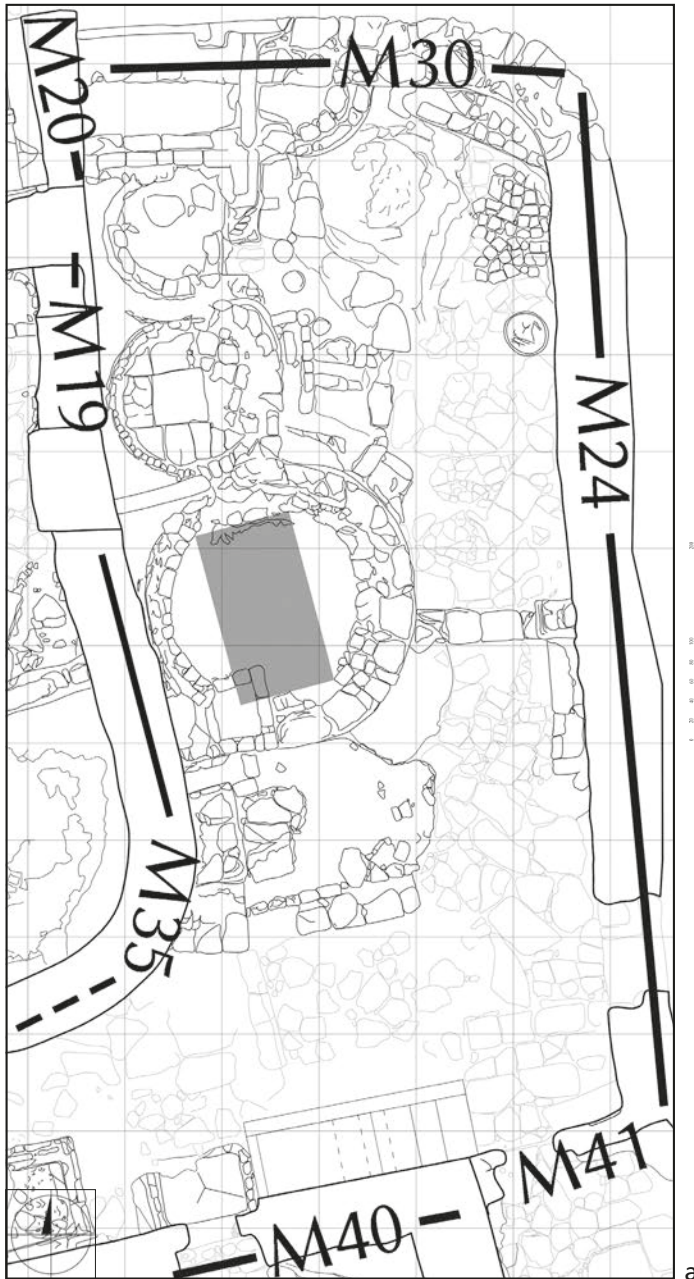

Schnitt 11. **a** Lokalisierung des Schnittes in OT_78. – **b** Zeichnung der Oberfläche. – **c** Oberfläche (Bef. 138-139). Blick nach W. – **d** Strukturen unter der Füllung (Bef. 153). Blick nach S. – (a-b Pläne K. Czarnitzki/S. Olschok; c-d Fotos S. Olschok).

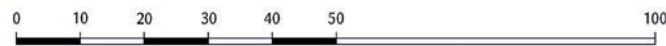
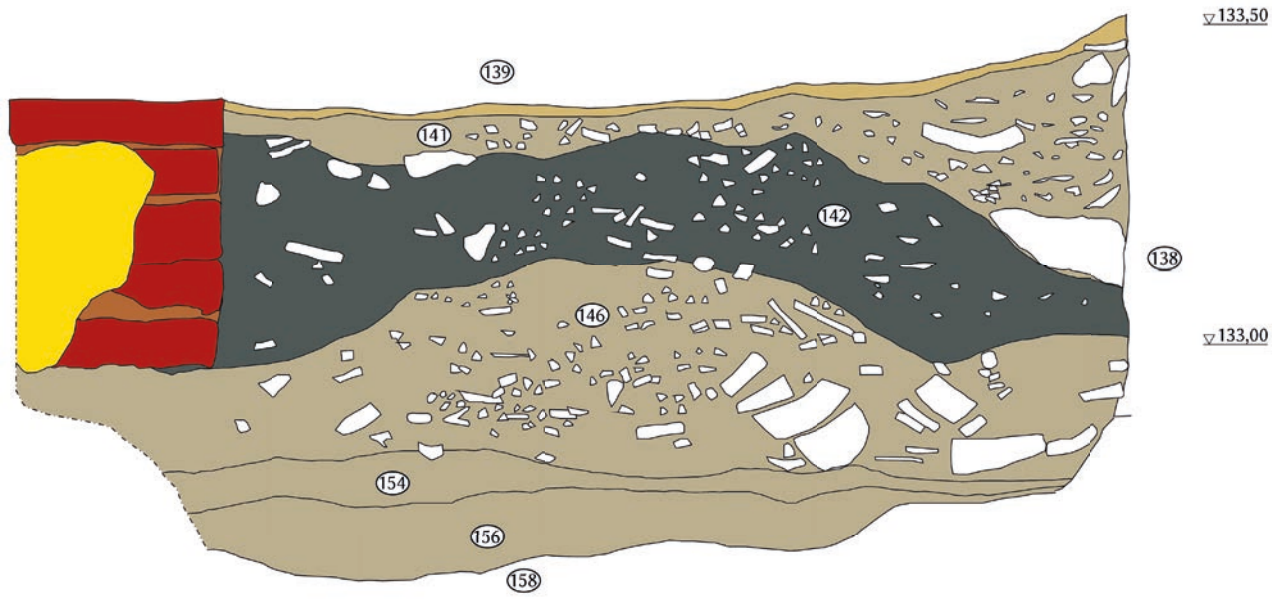

a

- | | | | |
|---|--------------|---|--------|
| ----- | Schnittkante | | Putz |
| | Stein | | Sand |
| | Ziegel | | Schutt |
| | Mörtel | | Schutt |



b

Schnitt 11. Profil 14. Blick nach W. **a** Zeichnung. – **b** Foto. – (Zeichnung/Foto S. Olschok).



a



b



c



d

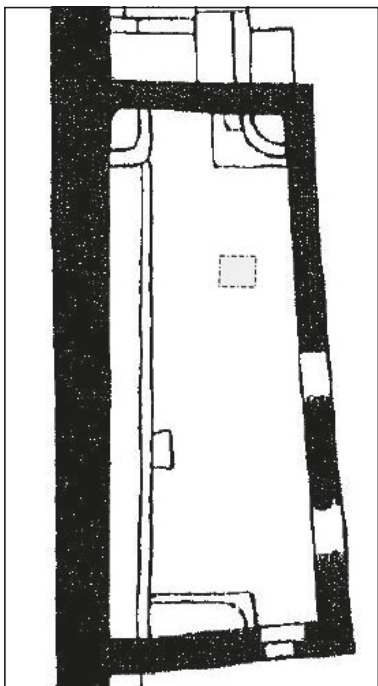

e



f

a Schnitt 12. Zeichnung der Oberfläche. – b Schnitt 12. Foto. Blick nach NW. – c Schnitt 13. Zeichnung der Oberfläche. – d Schnitt 13. Foto. Blick nach S. – e Schnitt 15. Entnahmestelle. – f Schnitt 15. Foto. Blick nach N. – (a, c Pläne K. Czarnitzki/S. Olschok; b, d Fotos S. Olschok; e nach Monneret de Villard, Monastero Abb. 90; f Foto M.-A. El-Dorry).

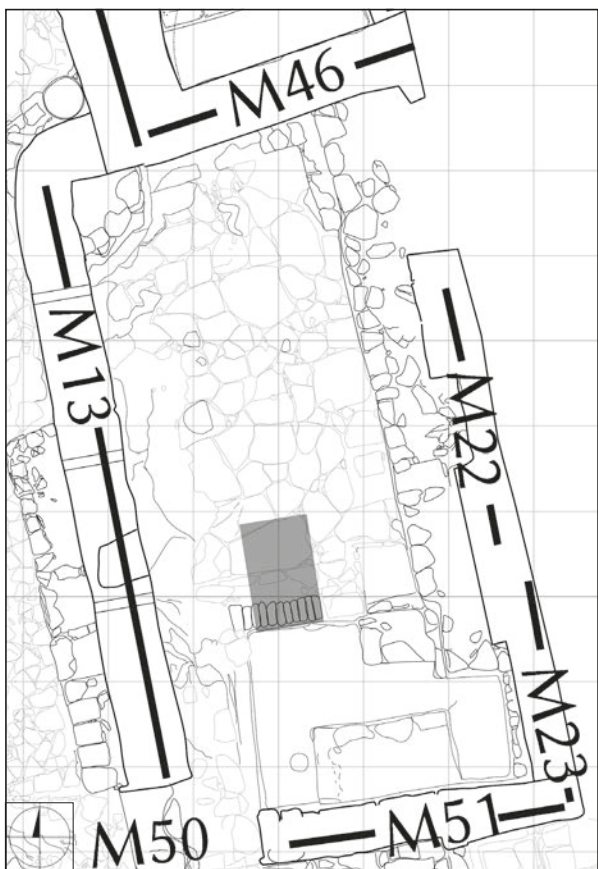

Schnitt 15. **a** Lokalisierung des Schnittes in OT_92. – **b** Zeichnung der Oberfläche. – **c** Oberfläche (Bef. 160-163). Blick nach S. – **d** Lehmestrich (Bef. 166) unter dem Fußboden. Blick nach S. – **e** mit Schutt (Bef. 178) hinterfüllte Steinwand (Bef. 170). Blick nach S. – **f** anstehender Fels. Blick nach S. – (a-b Pläne K. Czarnitzki/S. Olschok; c-f Fotos S. Olschok).

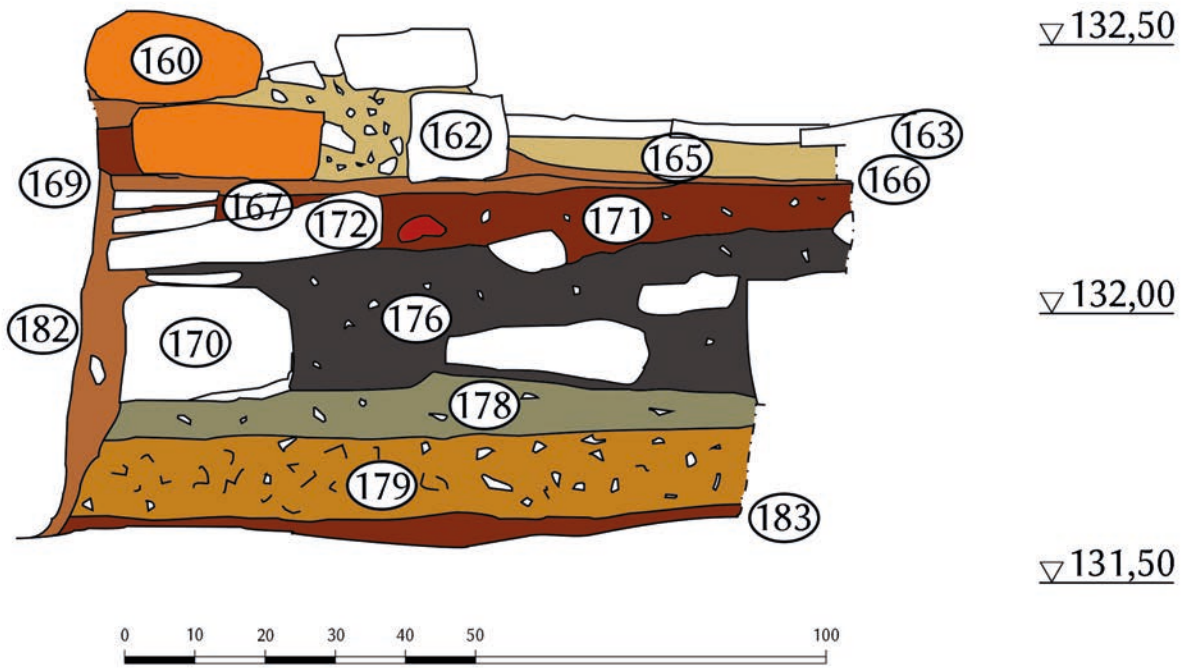

a

- | | | | |
|-------|--------------|---|--------|
| | Schnittkante | ■ | Sand |
| ◊ | Stein | ■ | Schutt |
| ■ | Lehmziegel | ■ | Schutt |
| ■ | Keramik | ■ | Schutt |
| ■ | Lehm | ■ | Schutt |



b

Schnitt 15. Profil 15. Blick nach W. a Zeichnung. – b Foto. – (Zeichnung/Foto S. Olschok).

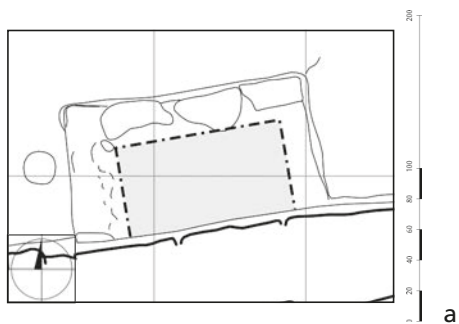

a

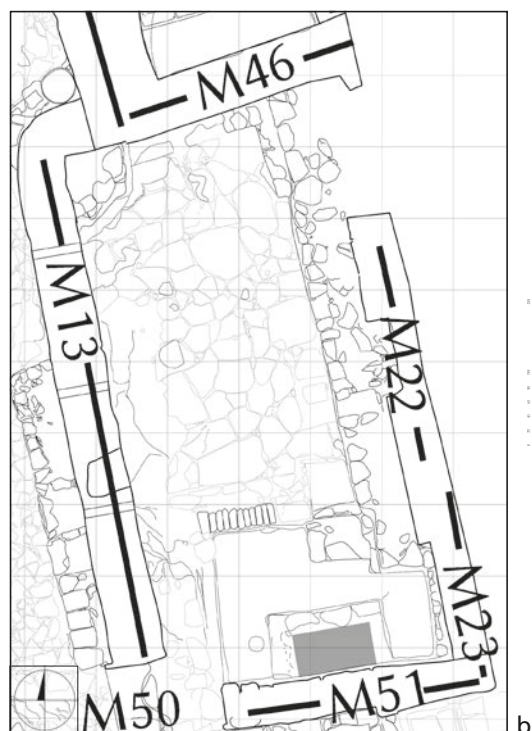

b



c

Schnitt 16. **a** Zeichnung der Oberkante. – **b** Lokalisierung des Schnittes in OT_92. – **c** Umrandung (Bef. 163) und Schuttfüllung (Bef. 164). Blick nach O. – (a-b Pläne K. Czarnitzki/S. Olschok; c Foto S. Olschok).

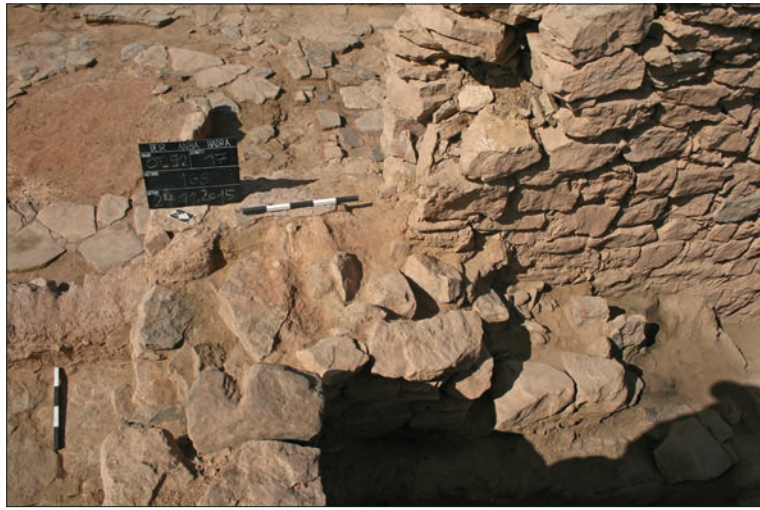
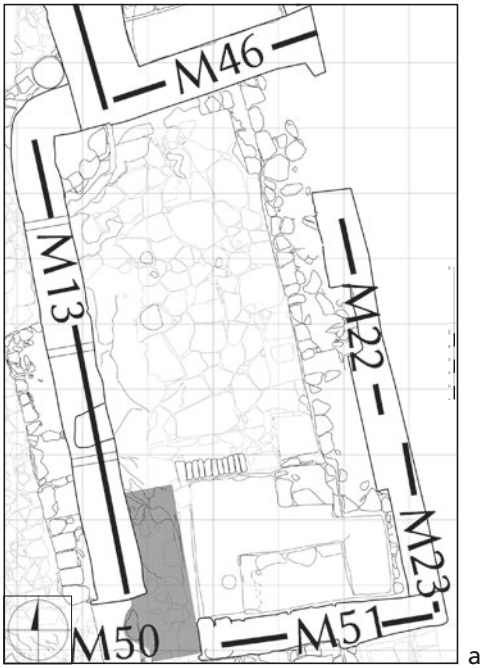

Schnitt 17. **a** Lokalisierung des Schnittes in OT_92. – **b** Zeichnung der Oberfläche. – **c** Oberfläche (Bef. 168). Blick nach W. – **d** Trog (Bef. 173) mit Verfüllung (Bef. 174). Blick nach W. – **e** Lehmauskleidung (Bef. 175) des Trogs. Blick nach W. – (a-b Pläne K. Czarnitzki/S. Olschok; c-e Fotos S. Olschok).



a



b



c



d

Schnitt 17. Blick nach S. **a** Lehmfußboden (Bef. 184). – **b** Schuttschicht (Bef. 185). – **c** Holz- und Bastreste (Bef. 188) im Schutt (Bef. 185). – **d** Fußboden (Bef. 187=161). – (Fotos S. Olschok).

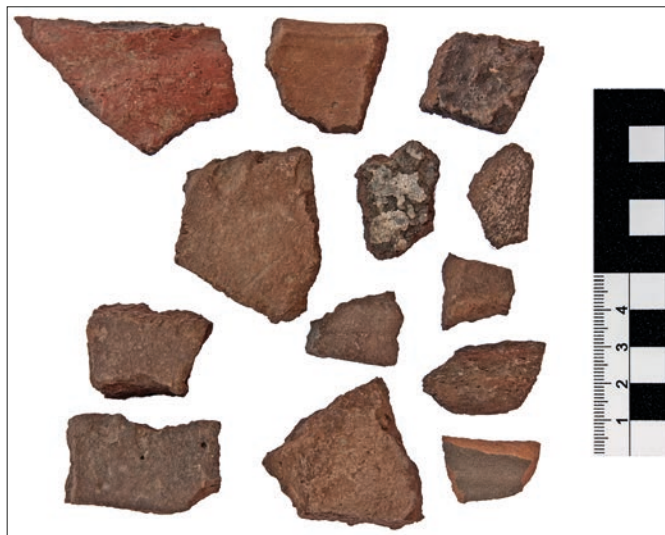
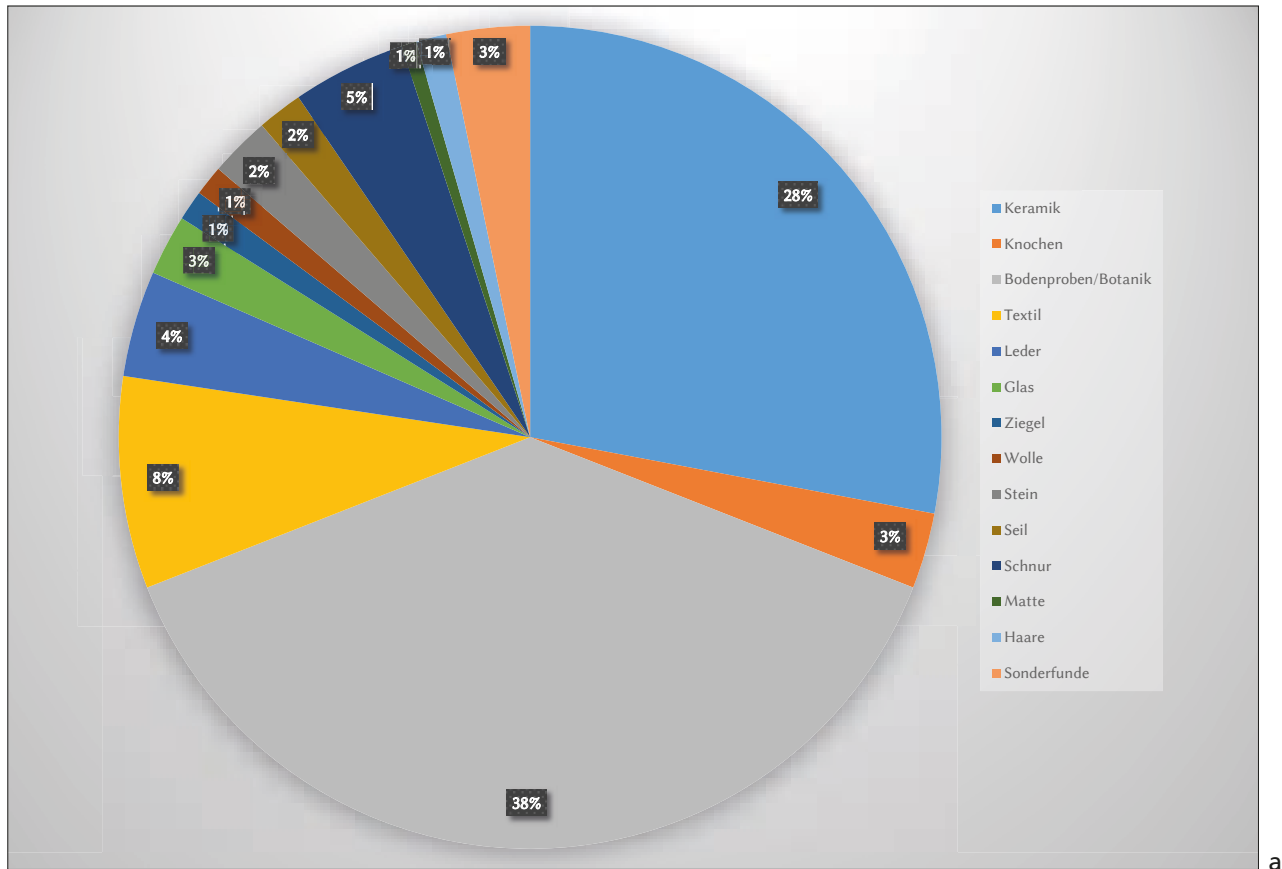

a Fundverteilung. – b Keramikdepot aus OT_74. – c »Pinke Aswan Ware« (Fd. 19). – d grobe Haushaltware (Fd. 54). – (a Diagramm S. Olschok; b Foto L. Krastel; c-d Fotos E. Koch).



a



b



c



d

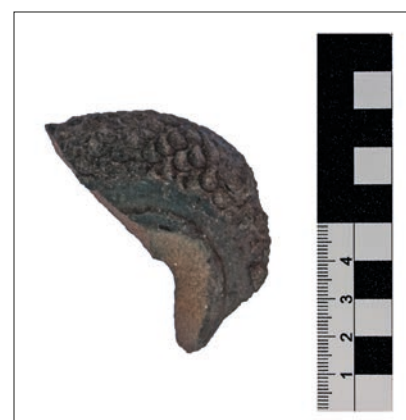

e

Keramikfunde. **a** dünnwandige rote Ware (Fd. 170). – **b** dünnwandige cremefarbige Ware (Fd. 119). – **c** reduziert gebrannte Ware (Fd. 81). – **d** bemalte Scherbe (Fd. 194). – **e** traubenförmige Ornamente (Fd. 126). – (Fotos S. Lutz).



a



b



c



d

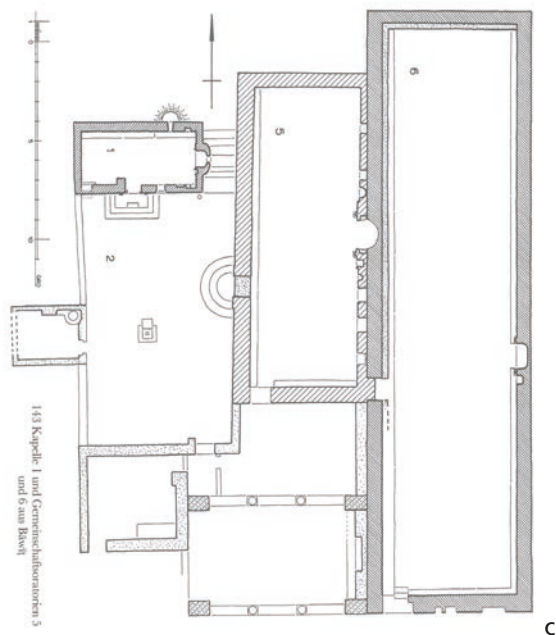
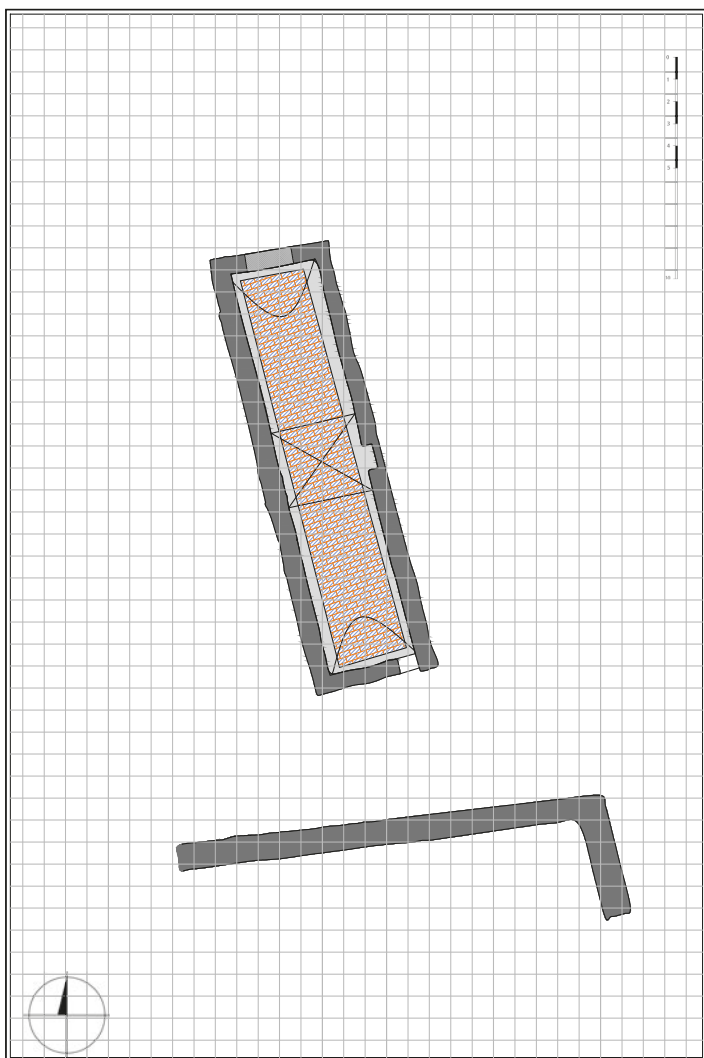

- Mauer
- Kalkestrich auf gebrannten Ziegeln

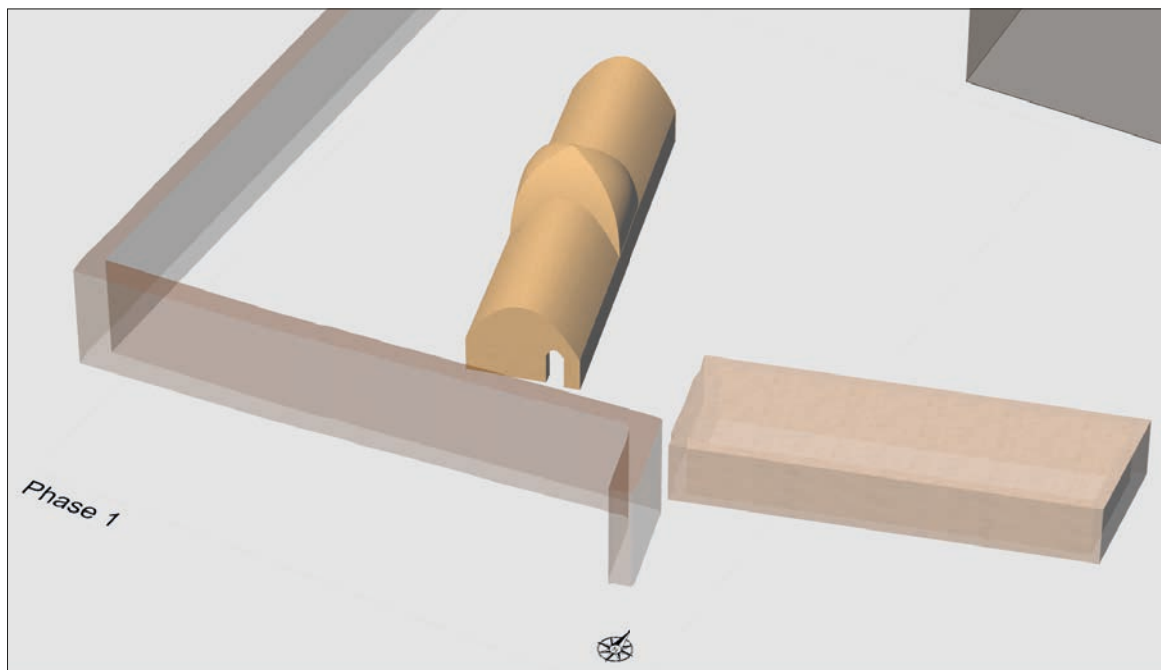

Phase 1 – Rekonstruktionsvorschlag. **a** Grundriss. – **b** 3D-Modell. – **c** Oratorien in Bawit. – (a-b Plan/Modell K. Czarnitzki/S. Olschok; c nach Grossmann, Christliche Architektur Abb. 143).

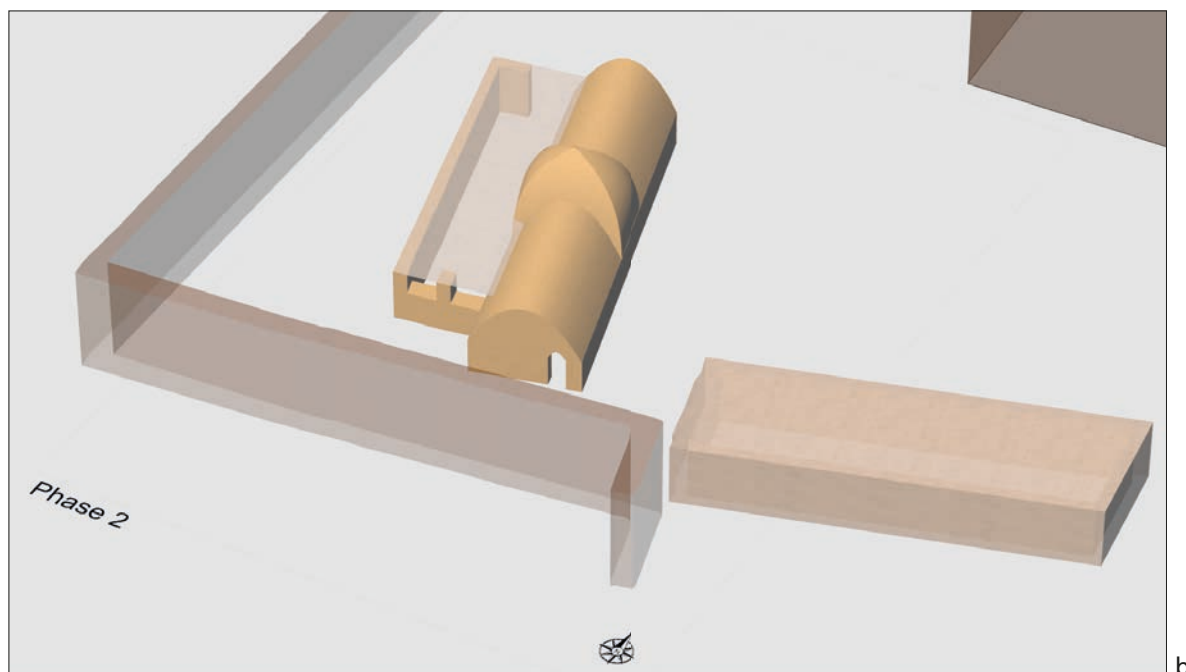
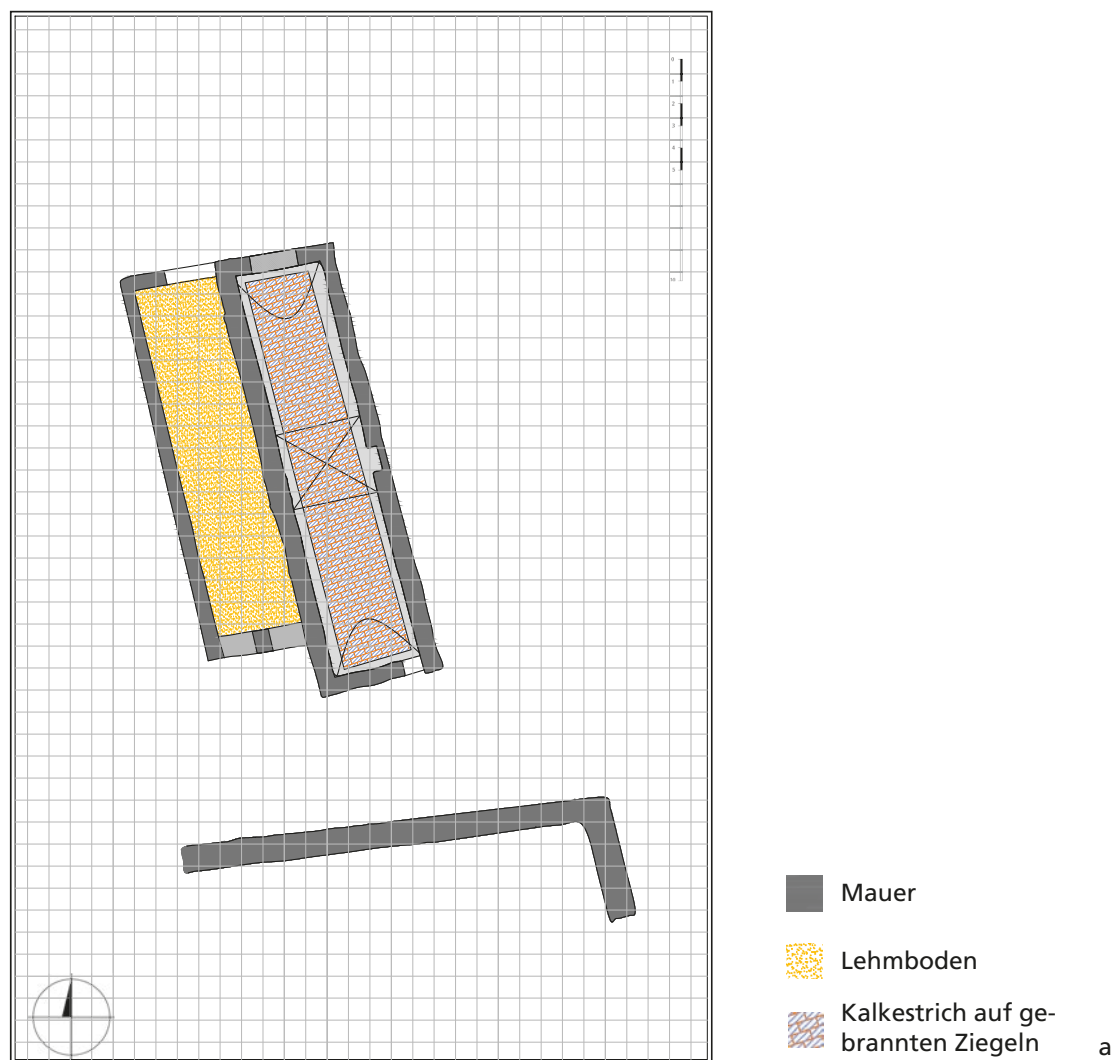

Phase 2 – Rekonstruktionsvorschlag. **a** Grundriss. – **b** 3D-Modell. – (Plan/Modell K. Czarnitzki/S. Olschok).

▽ 132,50

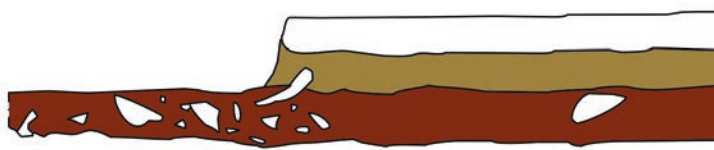

a

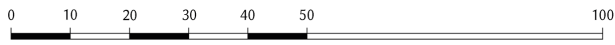

- Schnittkante
- ◊ Stein
- Lehm
- Splitt/Schotter



b

Profil 9. Blick nach O. **a** Zeichnung. – **b** Foto. – (Zeichnung/Foto S. Olschok).

▽ 132,50

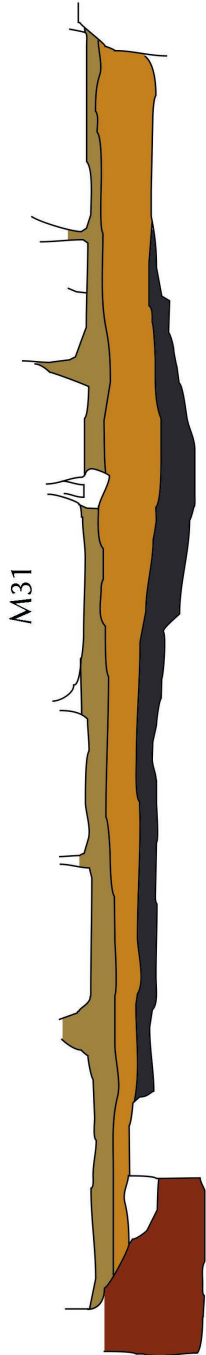

- Schnittkante
- Stein
- Lehm
- Splitt/Schotter
- Sand
- Splitt/Schotter

a



b

Profil 40. Blick nach S. a Zeichnung. – b Foto. – (Zeichnung/Foto S. Olschok).

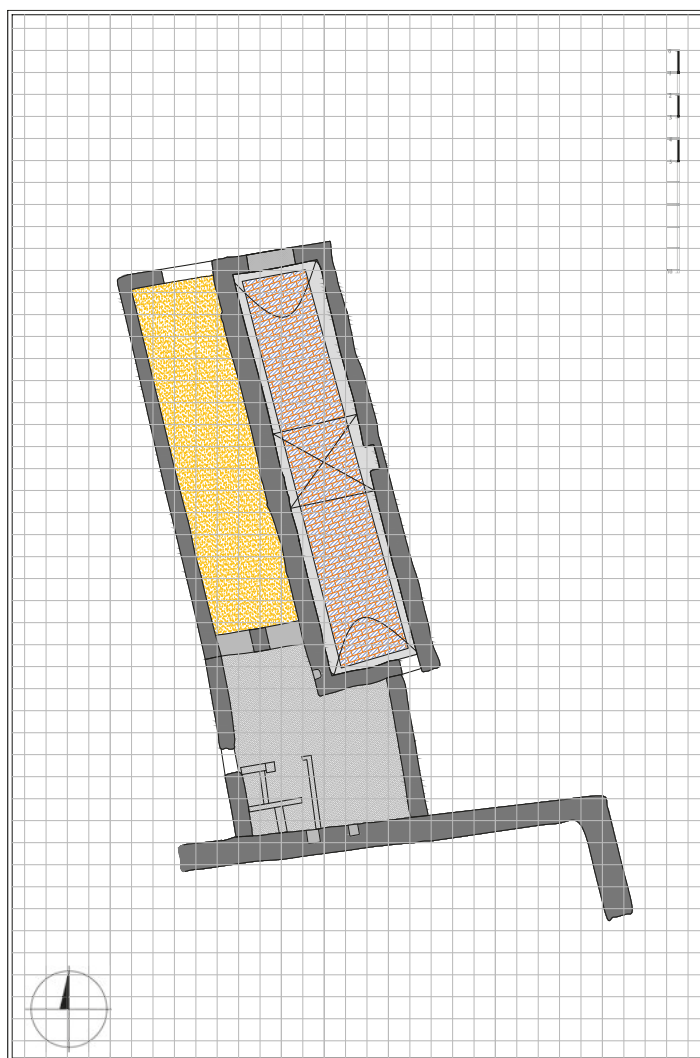

-  Mauer
-  Steinplatten
-  Lehmbooden
-  Kalkestrich auf gebrannten Ziegeln

a

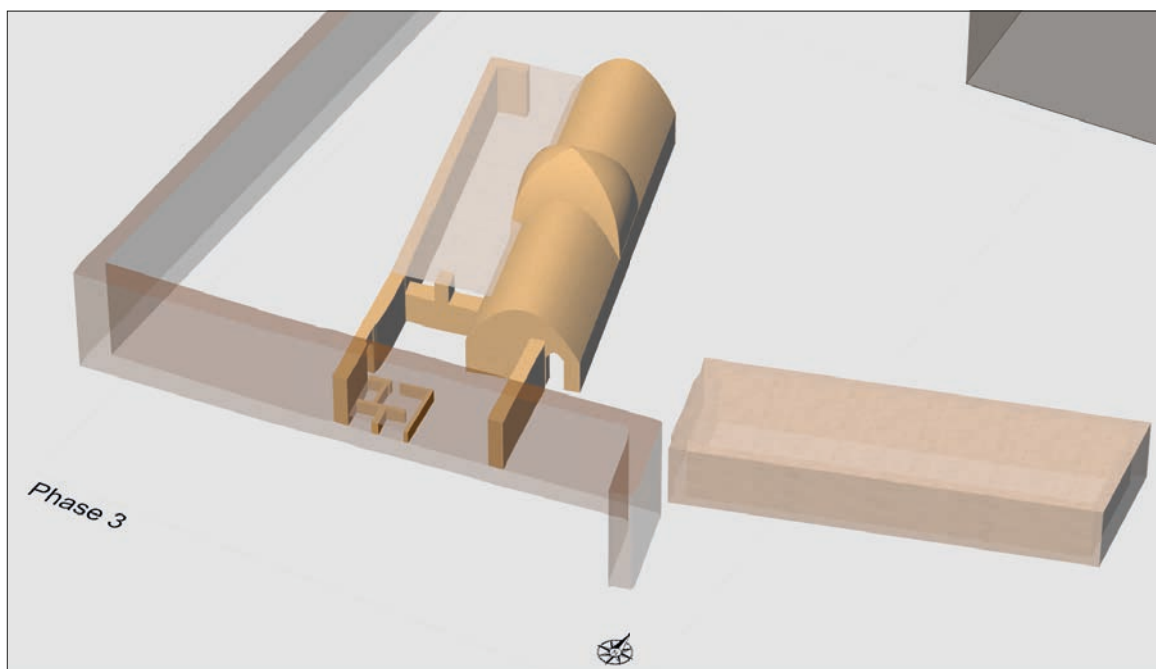

b

Phase 3 – Rekonstruktionsvorschlag. **a** Grundriss. – **b** 3D-Modell. – (Plan/Modell K. Czarnitzki/S. Olschok).

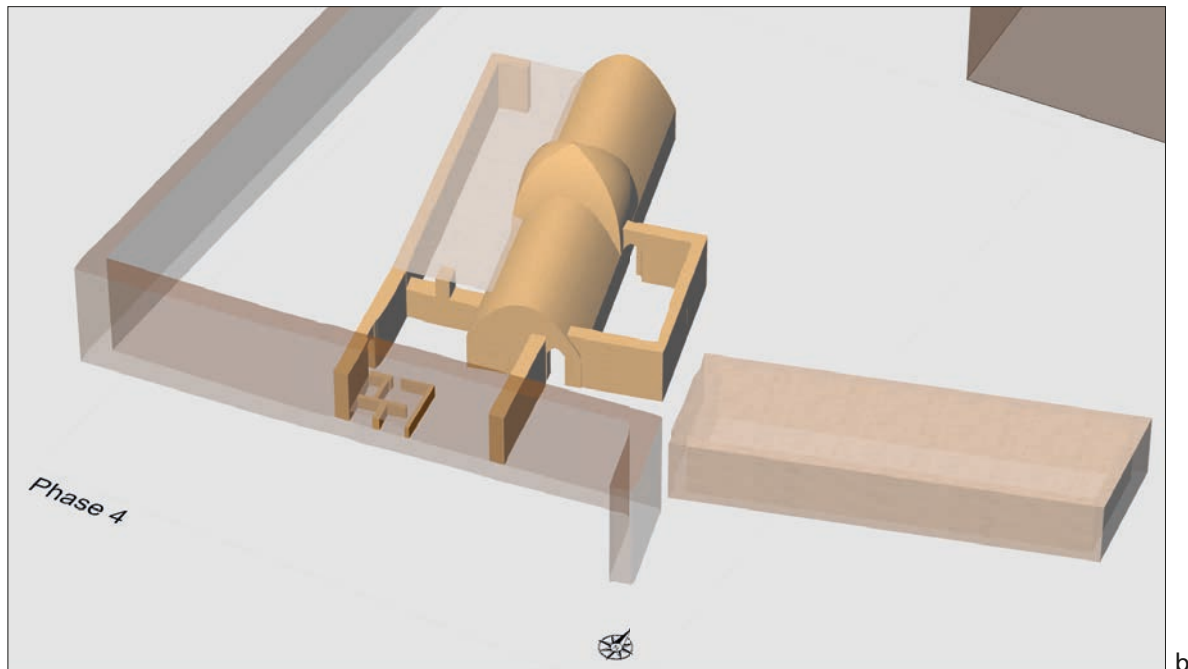
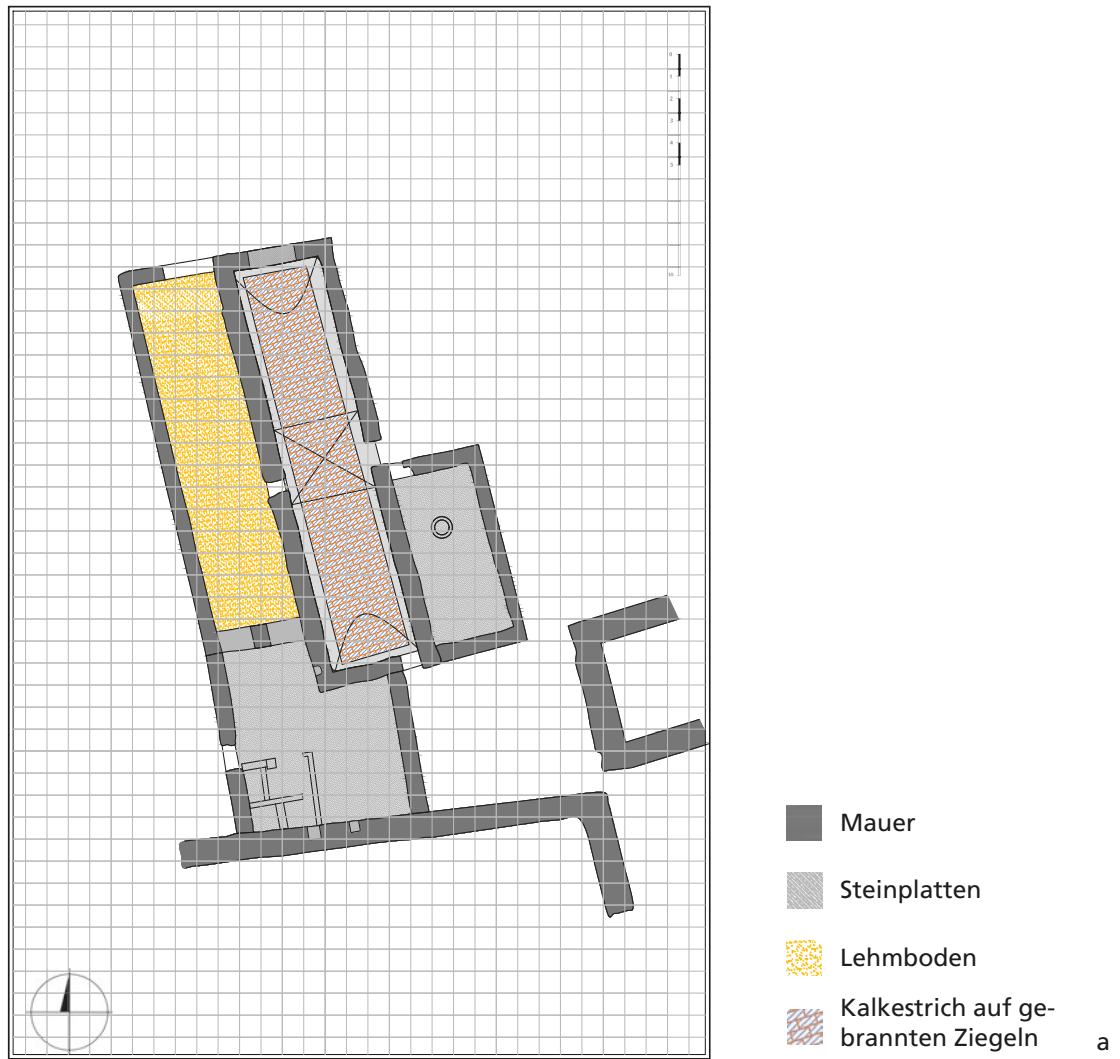

Phase 4 – Rekonstruktionsvorschlag. **a** Grundriss. – **b** 3D-Modell. – (Plan/Modell K. Czarnitzki/S. Olschok).



a



b



c

a Baufuge zwischen M16 u. M46. Blick nach N. – b Baukörper (OT_71/72). Blick nach N. – c Baufuge zwischen M22 & M23 auf Fundamentsockel (Blick nach O). –
(a Foto S. Lutz; b-c Fotos S. Olschok).

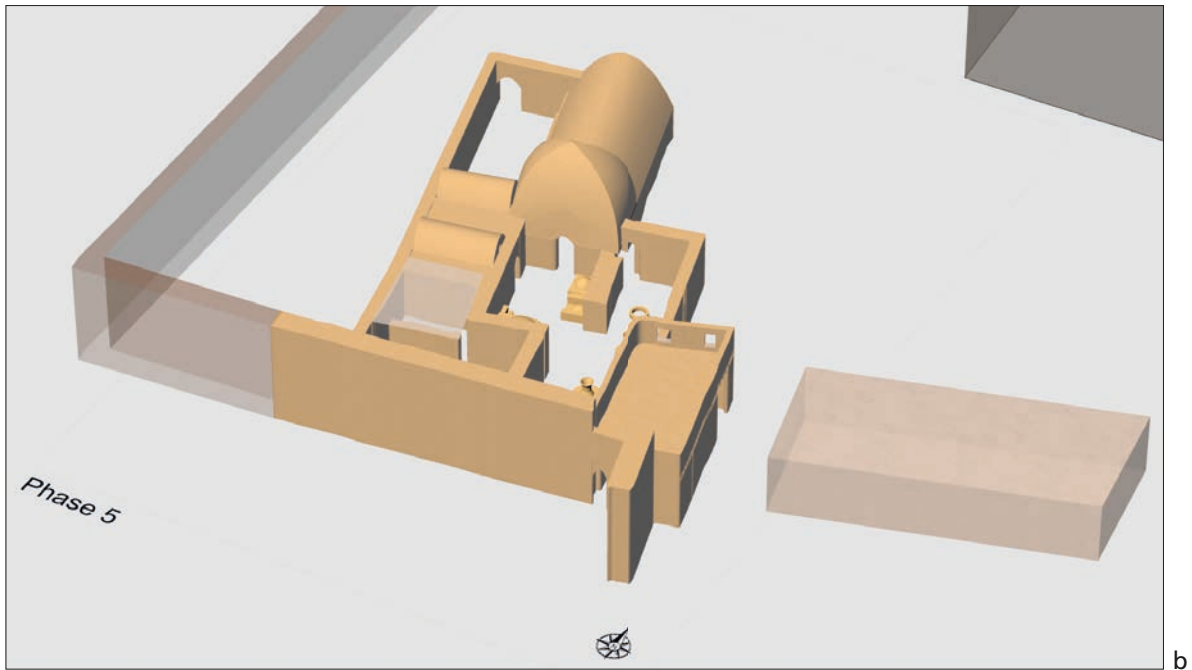
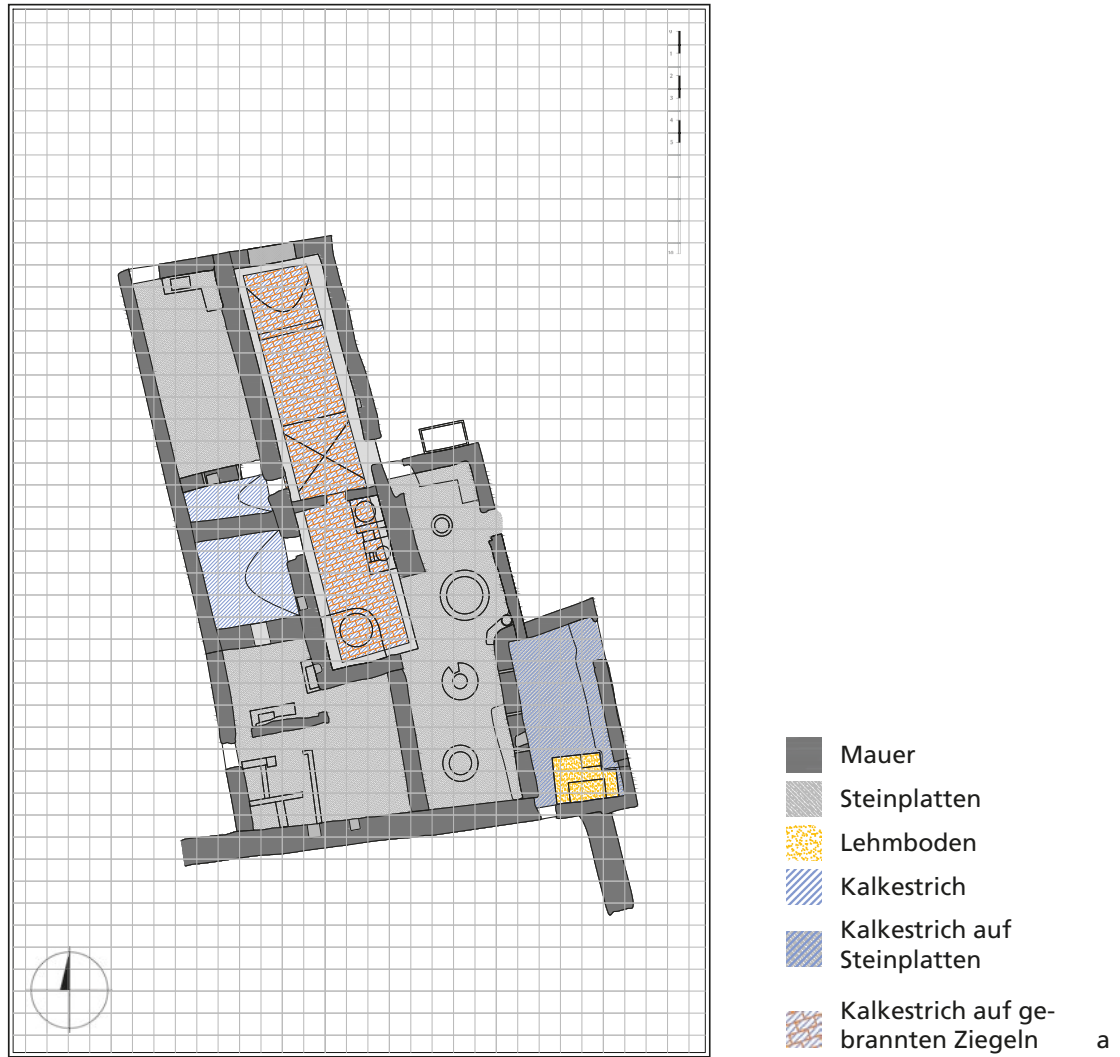

Phase 5 – Rekonstruktionsvorschlag a Grundriss. – b 3D-Modell. – (Plan/Modell K. Czarnitzki/S. Olschok).

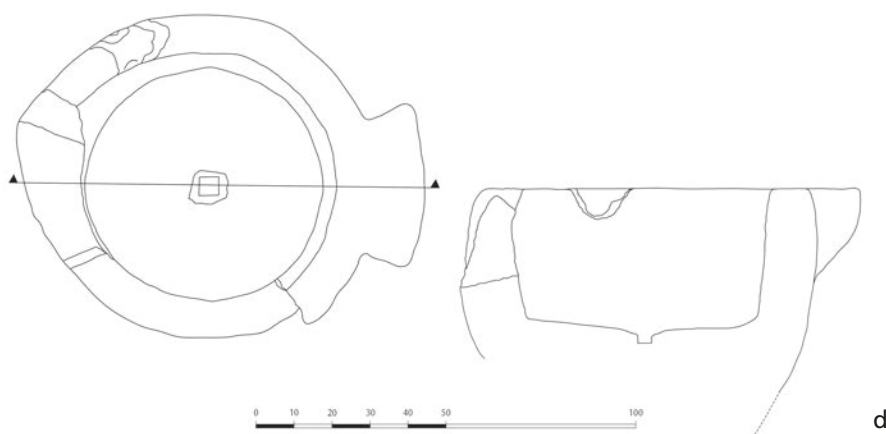
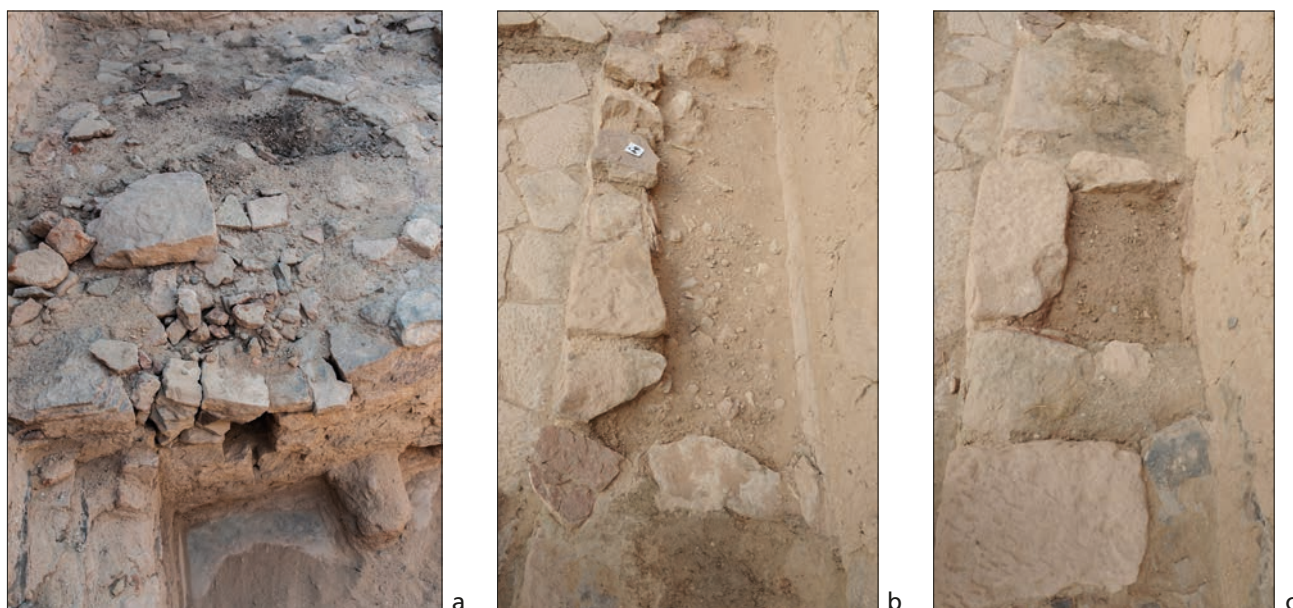

a Detail Ofenplattform. Blick nach W. – **b** Bankett. N-Abschnitt. Blick nach N. – **c** Bankett. S-Abschnitt. Blick nach N. – **d** Steingefäß aus Granit. Zeichnung. – **e** Steingefäß aus Granit. Foto. – (Fotos/Zeichnung S. Olschok).

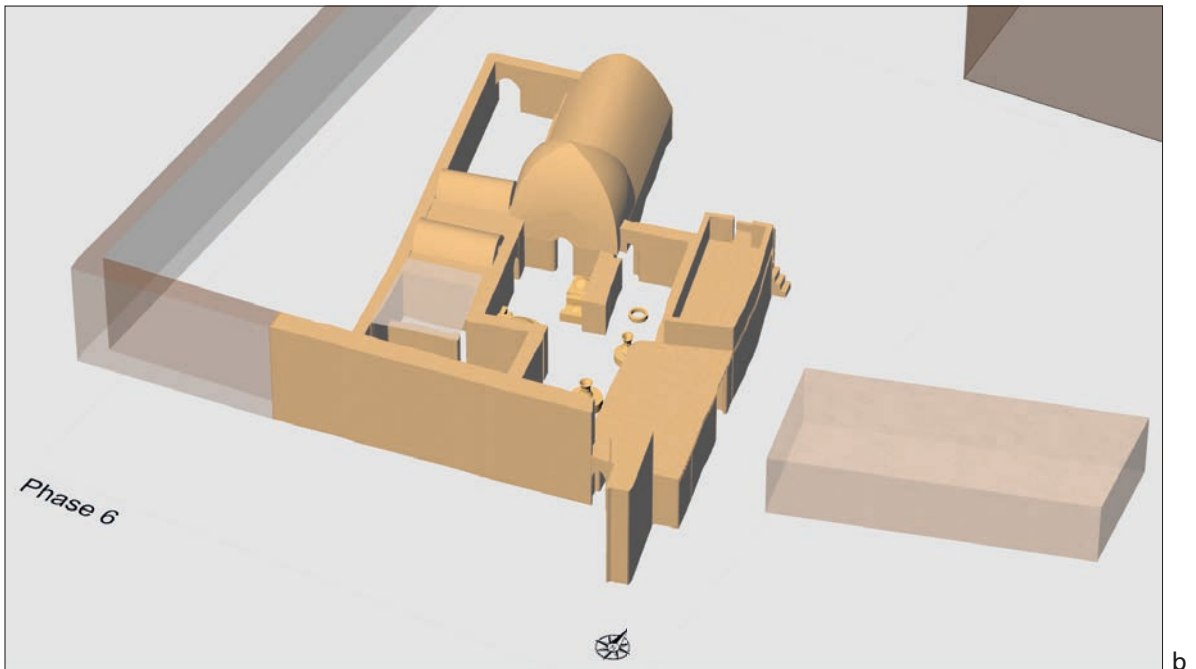
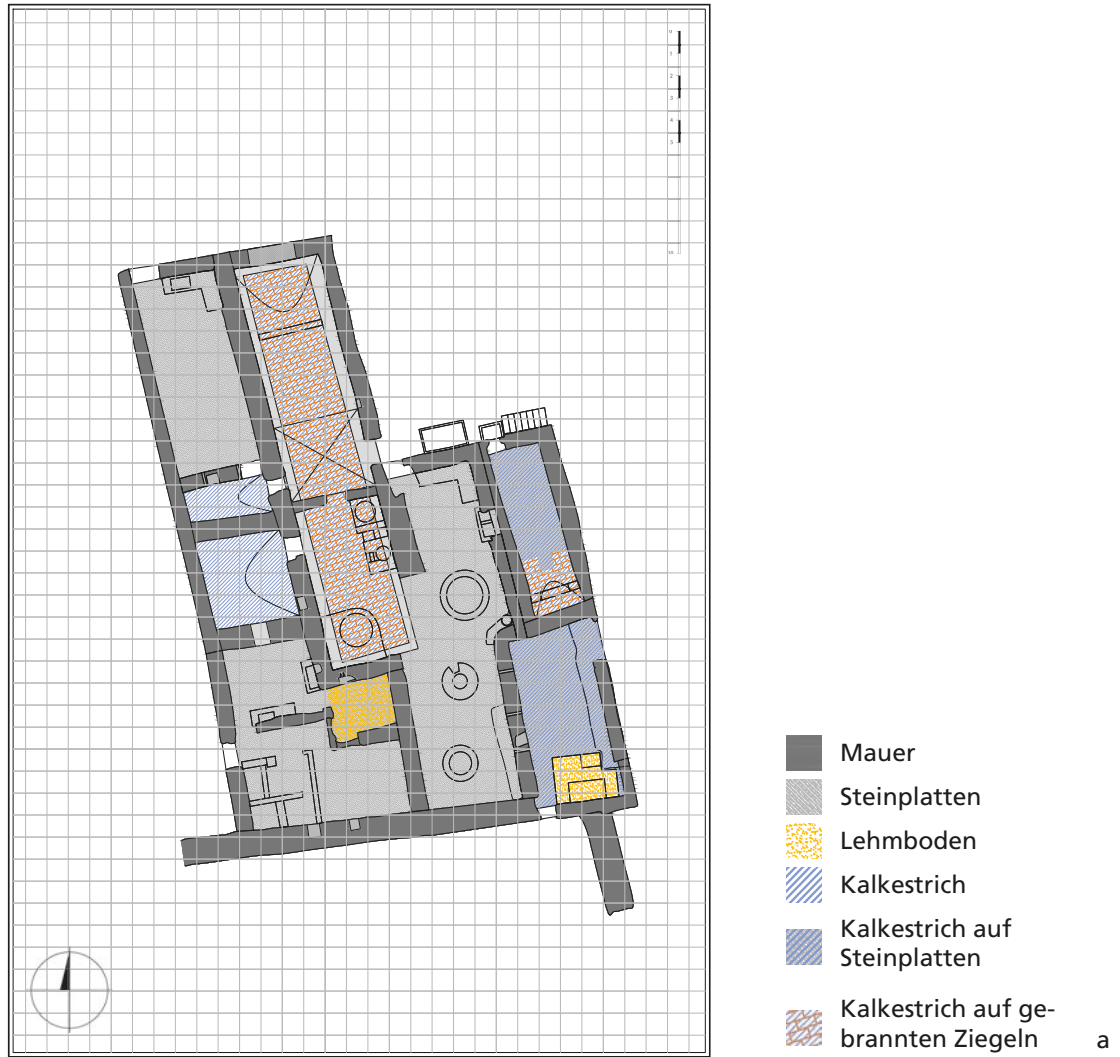

Phase 6 – Rekonstruktionsvorschlag a Grundriss. – b 3D-Modell. – (Plan/Modell K. Czarnitzki/S. Olschok).

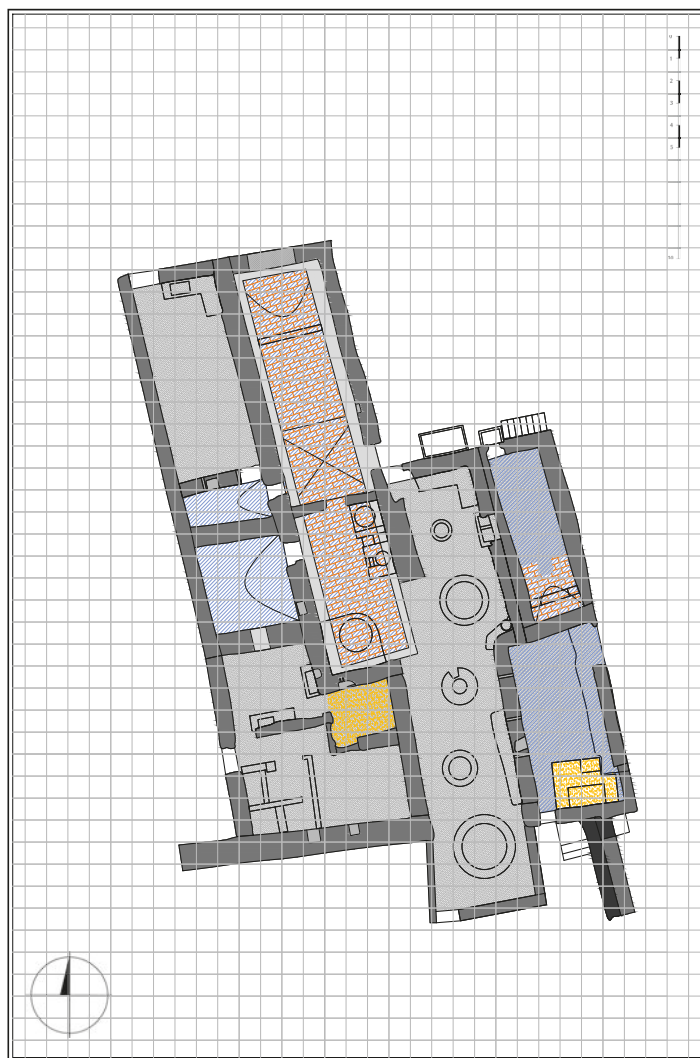

- Mauer
- Steinplatten
- Lehmbo-
- Kalkestrich
- Kalkestrich auf Steinplatten
- Kalkestrich auf gebrannten Ziegeln

a

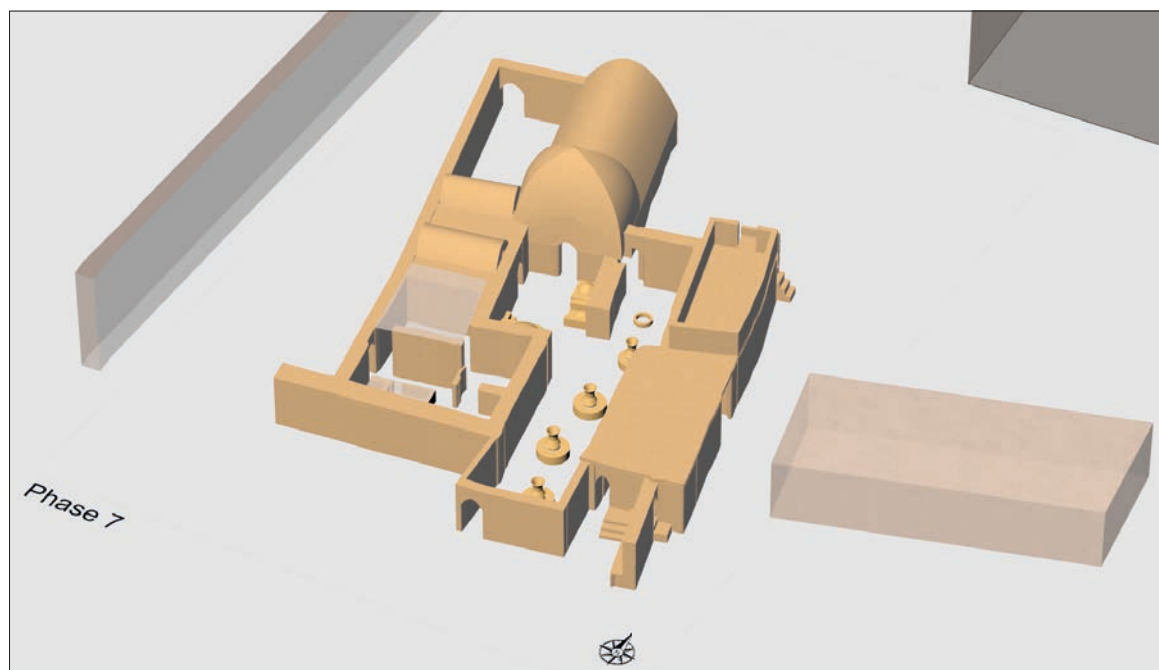

b

Phase 7 – Rekonstruktionsvorschlag **a** Grundriss. – **b** 3D-Modell. – (Plan/Modell K. Czarnitzki/S. Olschok).



a



c



b

a M18. Blick nach NO. – b M18 N-Teil. Orthofoto – c Türzarge in M51. Blick nach NW. – (Fotos S. Olschok).

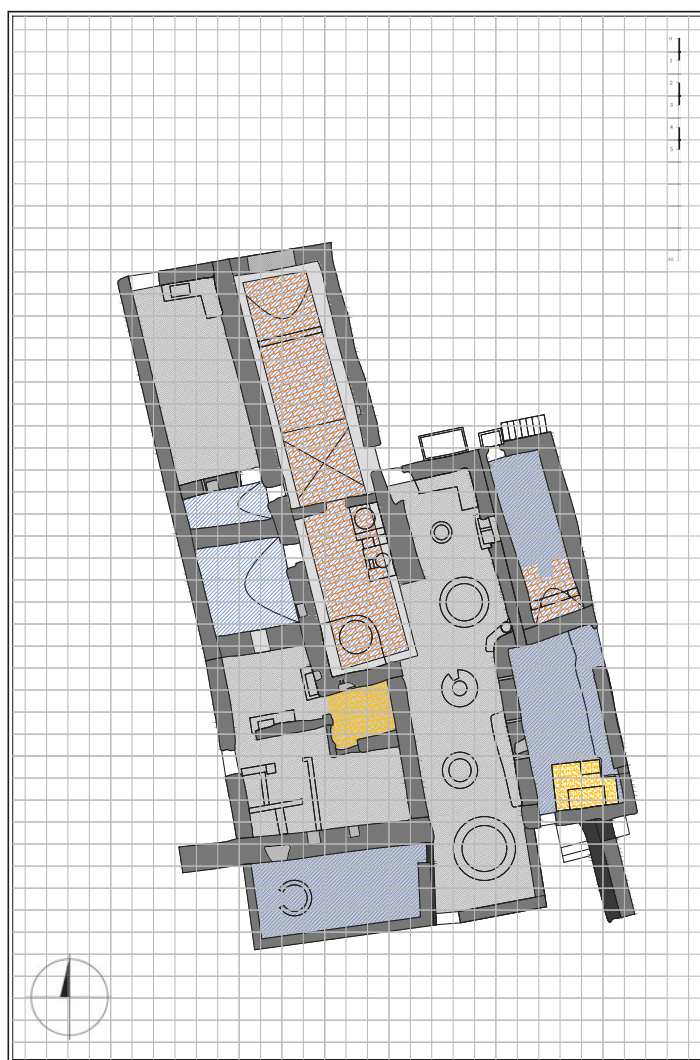

- Mauer
- Steinplatten
- Lehm Boden
- Kalkstrich
- Kalkstrich auf Steinplatten
- Kalkstrich auf gebrannten Ziegeln

a

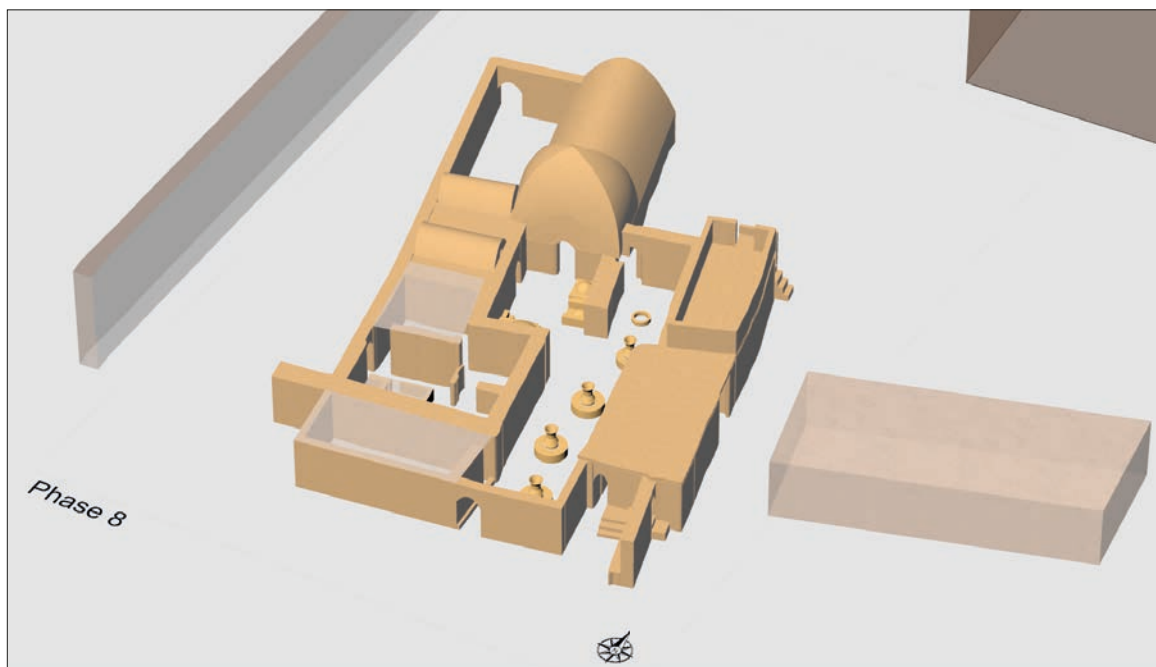

b

Phase 8 – Rekonstruktionsvorschlag **a** Grundriss. – **b** 3D-Modell. – (Plan/Modell K. Czarnitzki/S. Olschok).

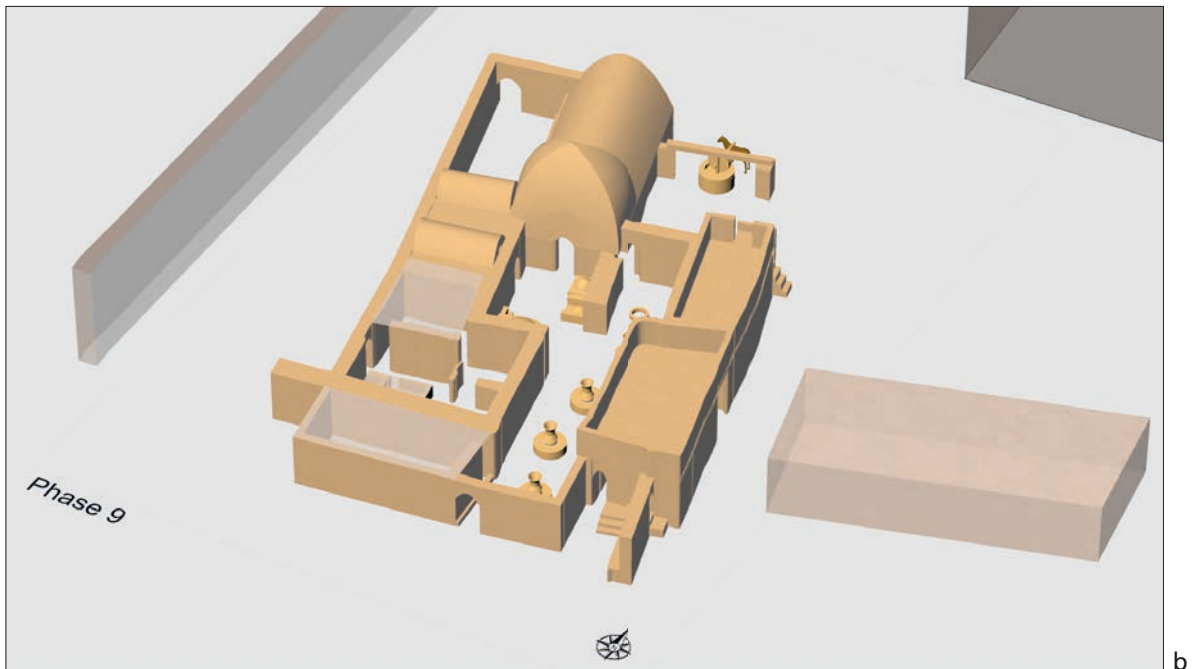
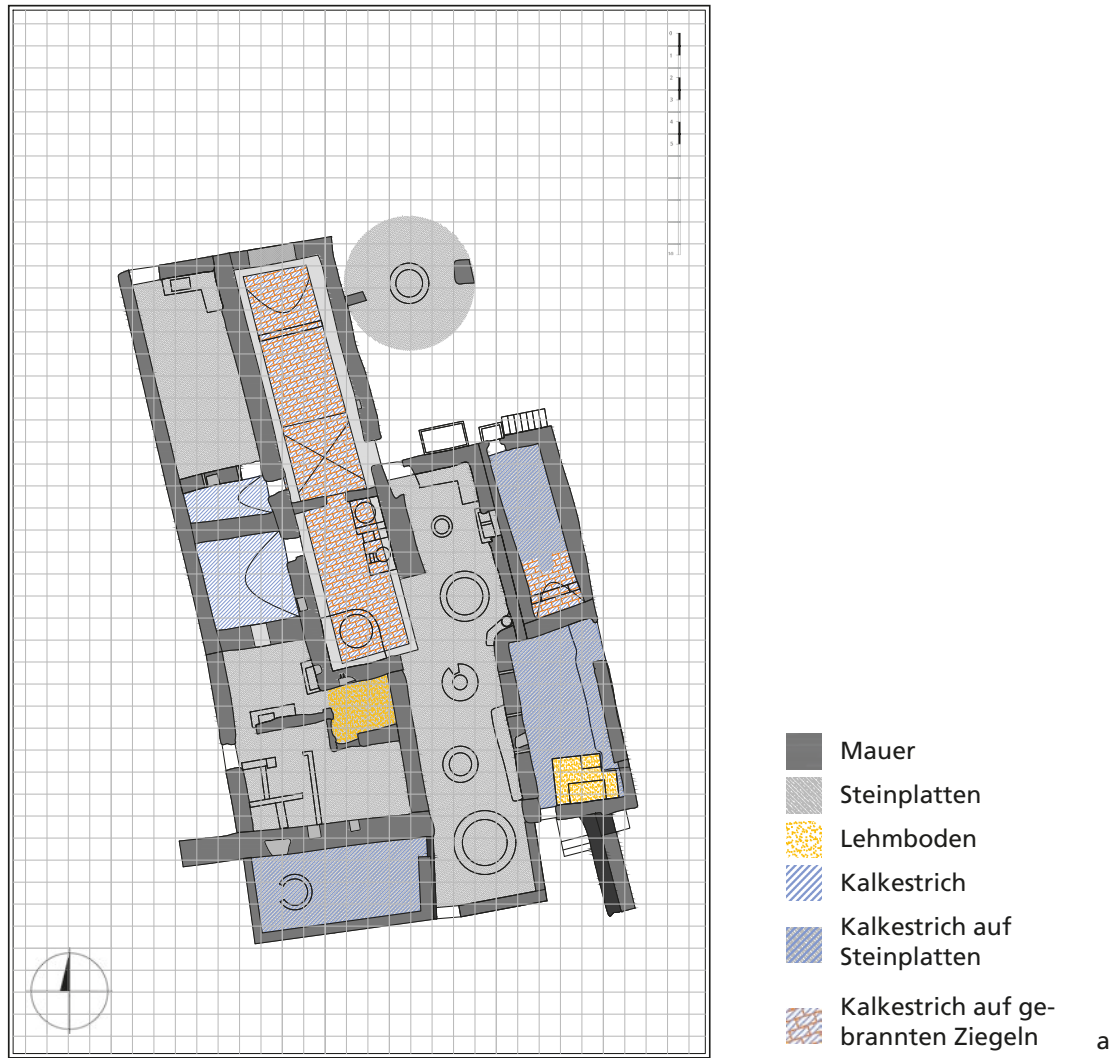

Phase 9 – Rekonstruktionsvorschlag a Grundriss. – b 3D-Modell. – (Plan/Modell K. Czarnitzki/S. Olschok).

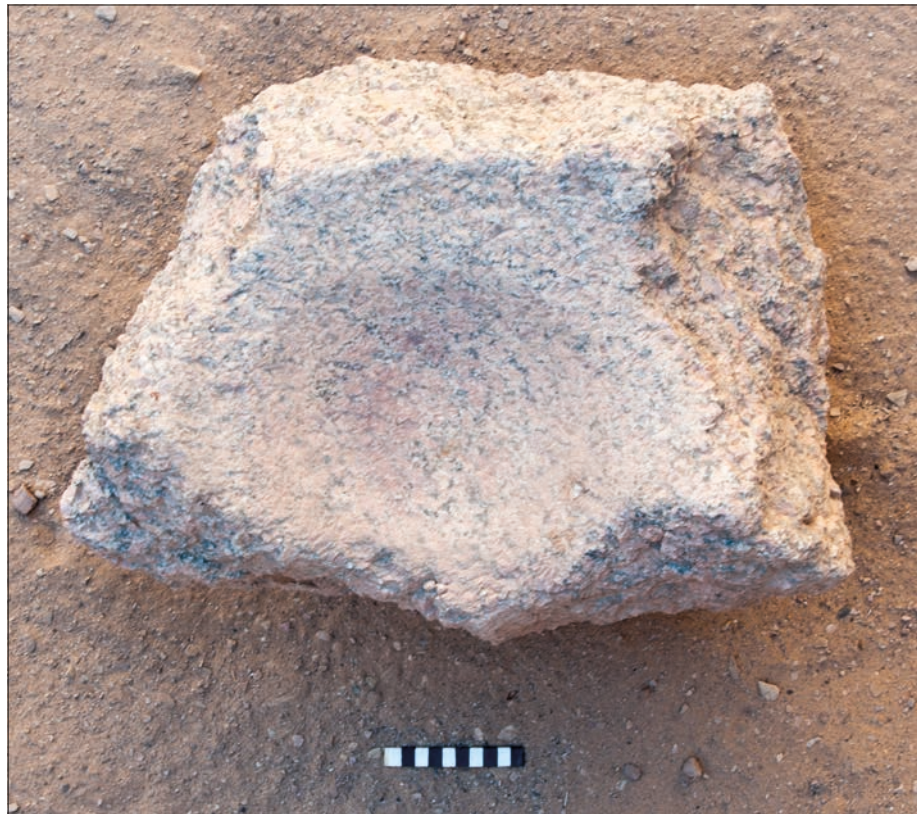

a



b

a Steingefäßfragment. Lese fund. – b Rekonstruktion einer Kollermühle im Antoniuskloster (Ägypten). – (Fotos S. Olschok).

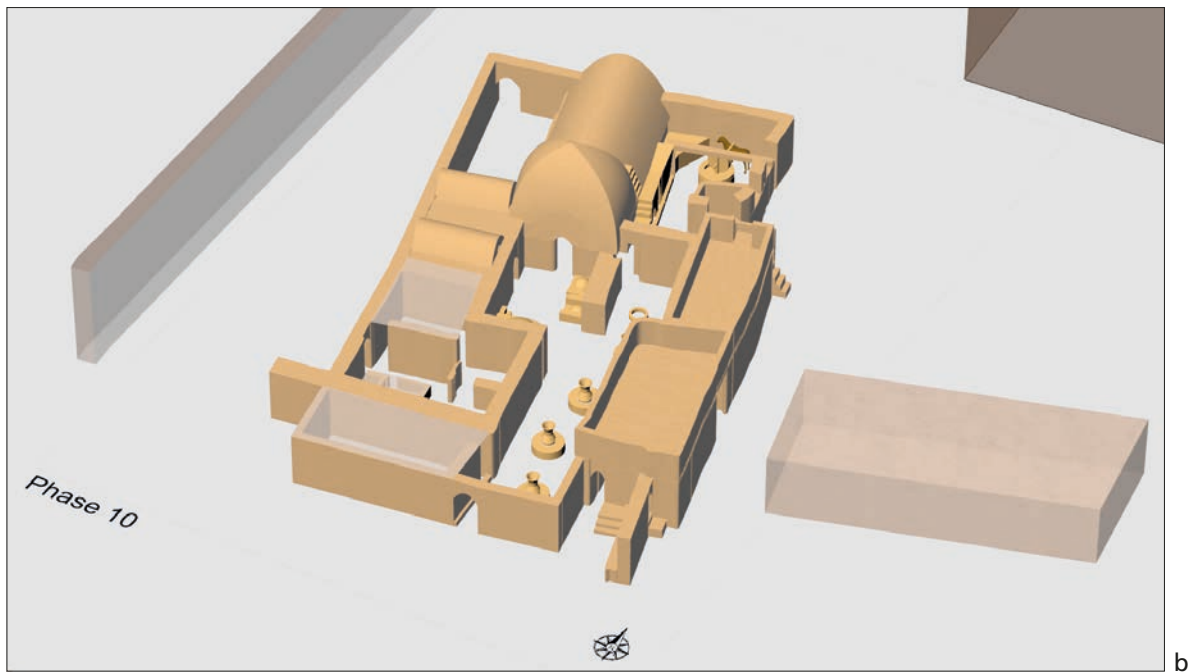

Phase 10 – Rekonstruktionsvorschlag **a** Grundriss. – **b** 3D-Modell. – (Plan/Modell K. Czarnitzki/S. Olschok).



a



b



c



d

a Steinpfeiler auf M35. Blick nach SO. – b Nische in M35. Blick nach S. – c nördlicher Lagerraum. Blick nach W. – d Lagerraum unter Treppe. Blick nach W. – (Fotos S. Olschok).

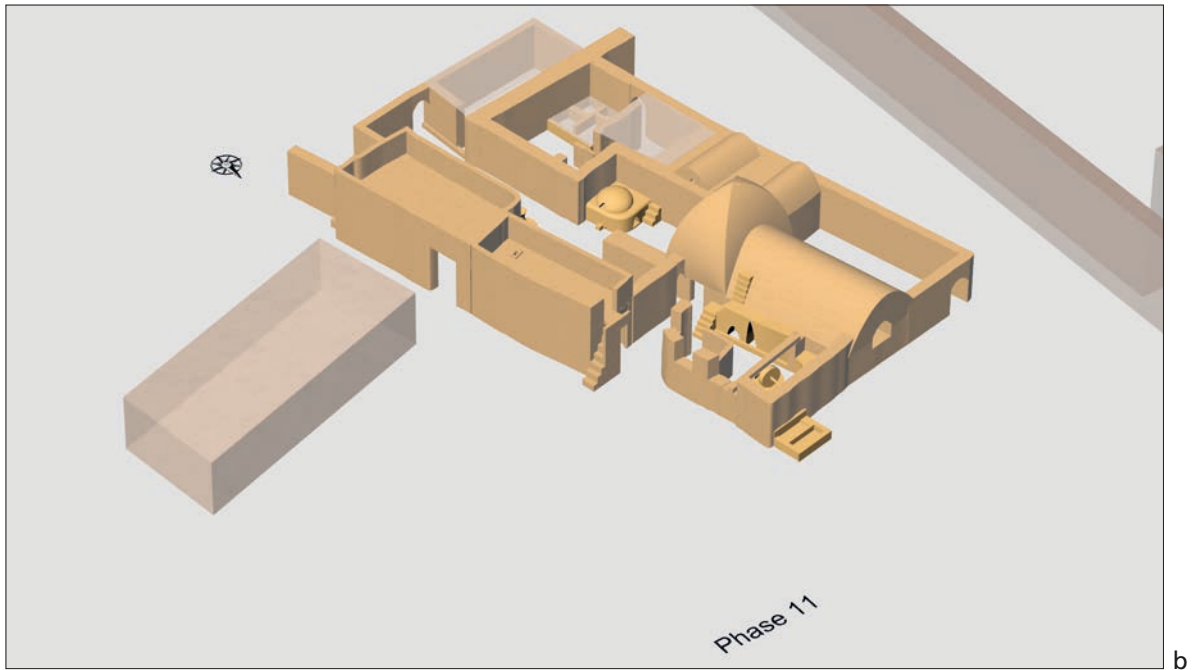
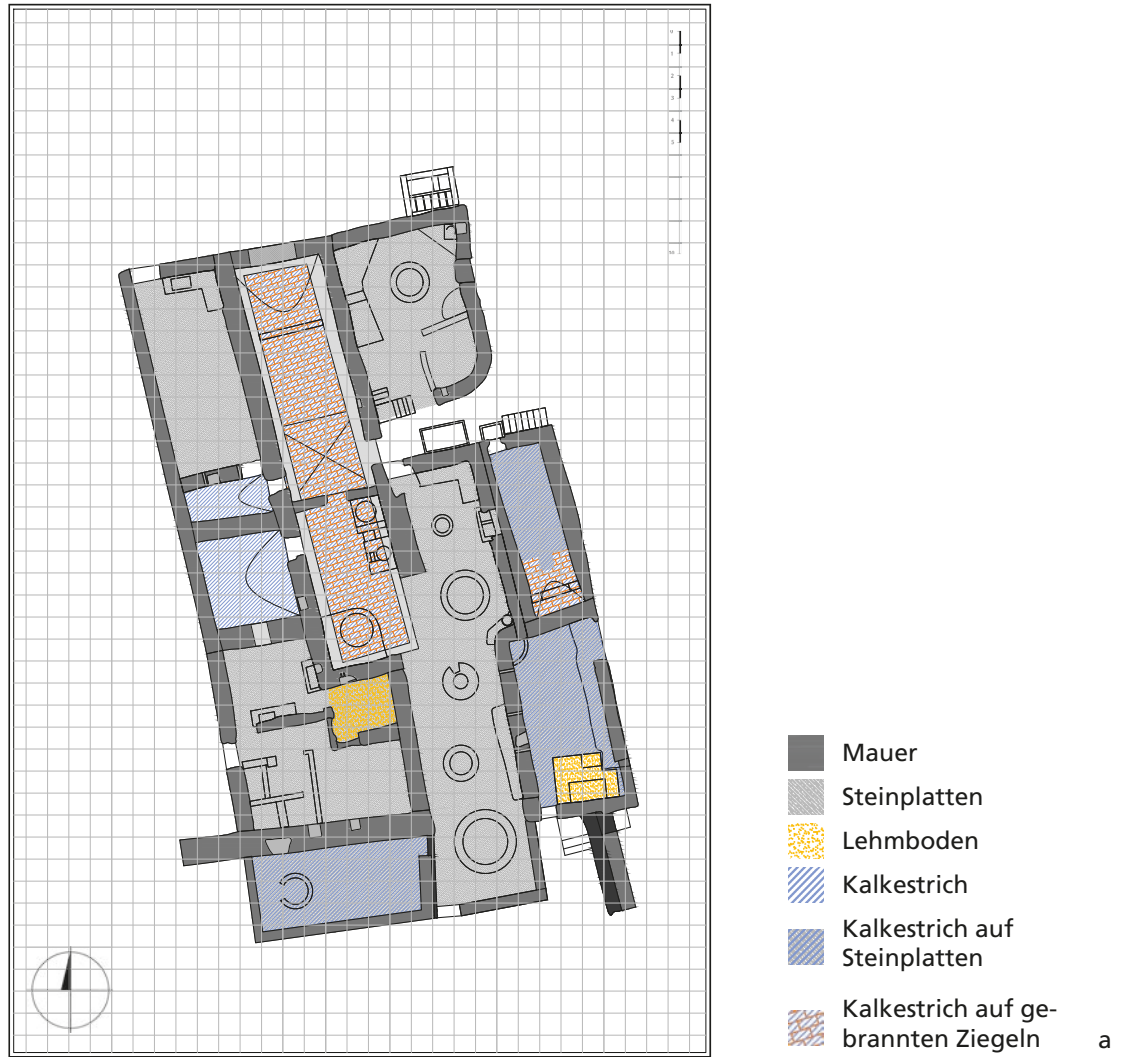

Phase 11 – Rekonstruktionsvorschlag a Grundriss. – b 3D-Modell. – (Plan/Modell K. Czarnitzki/S. Olschok).

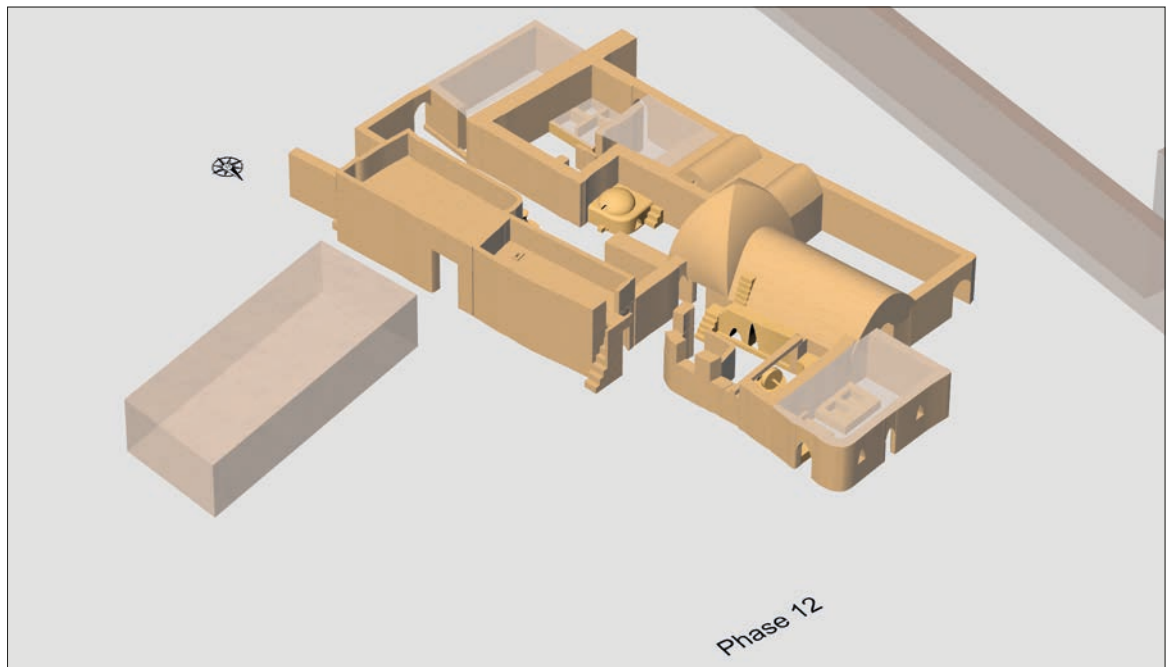
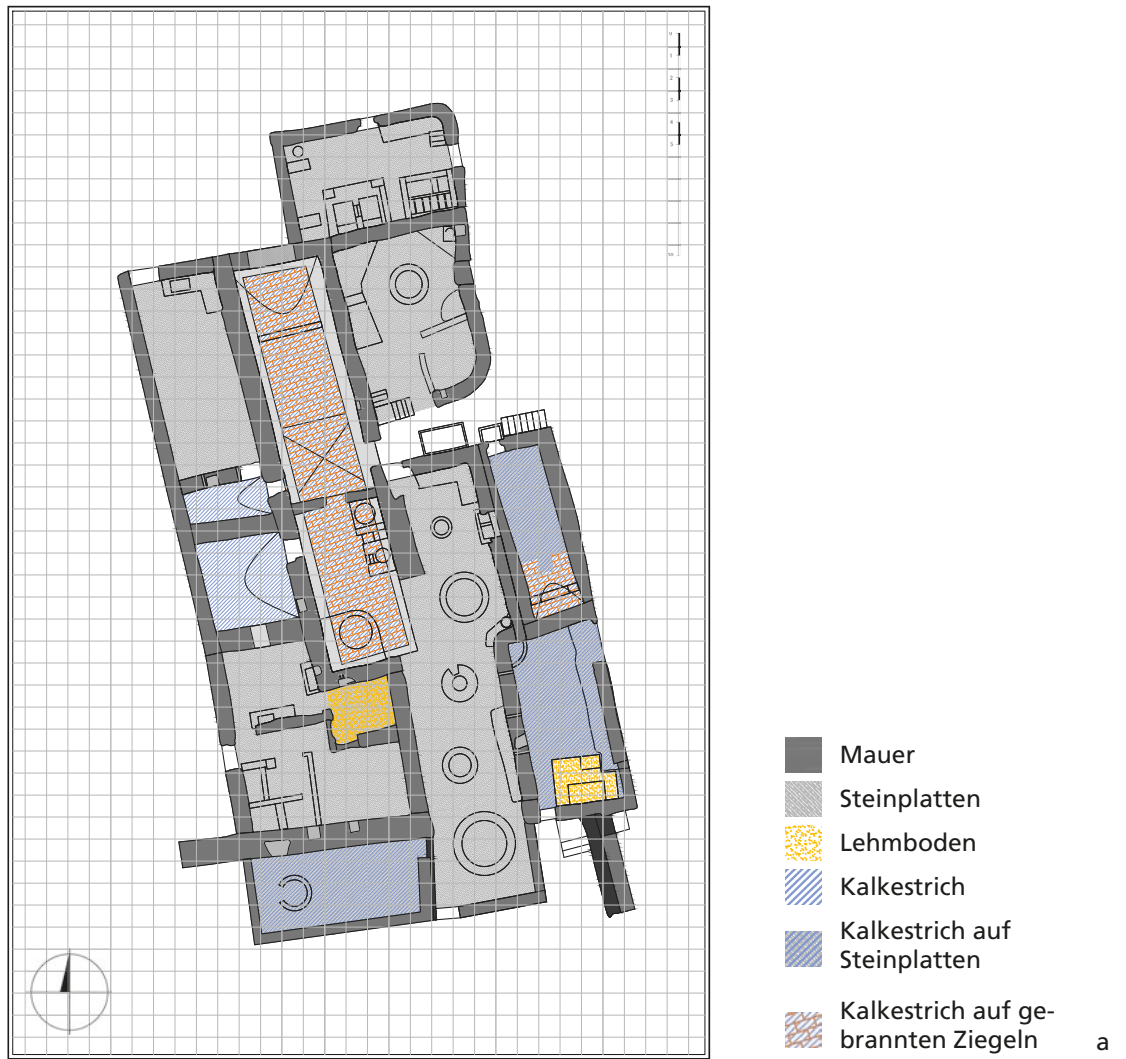

Phase 12 – Rekonstruktionsvorschlag **a** Grundriss. – **b** 3D-Modell. – (Plan/Modell K. Czarnitzki/S. Olschok).



a



b



c

Beckendetails OT_87/88. **a** Putzkante zwischen M10 und M32. Blick nach SO. – **b** Stufe an M10 und Fundament aus gebrannten Ziegeln. Blick nach S. – **c** Matte zwischen Beckenoberkante und Lehmziegelaufbau. Blick nach S. – (Fotos S. Olschok).

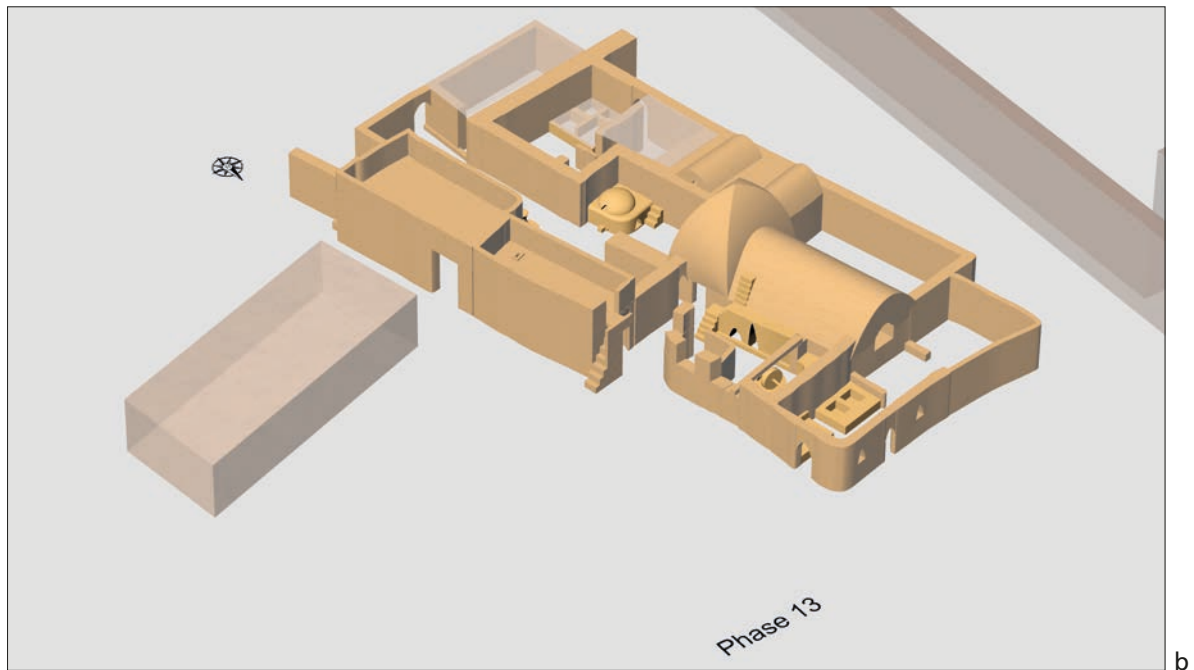

Phase 13 – Rekonstruktionsvorschlag a Grundriss. – b 3D-Modell. – (Plan/Modell K. Czarnitzki/S. Olschok).

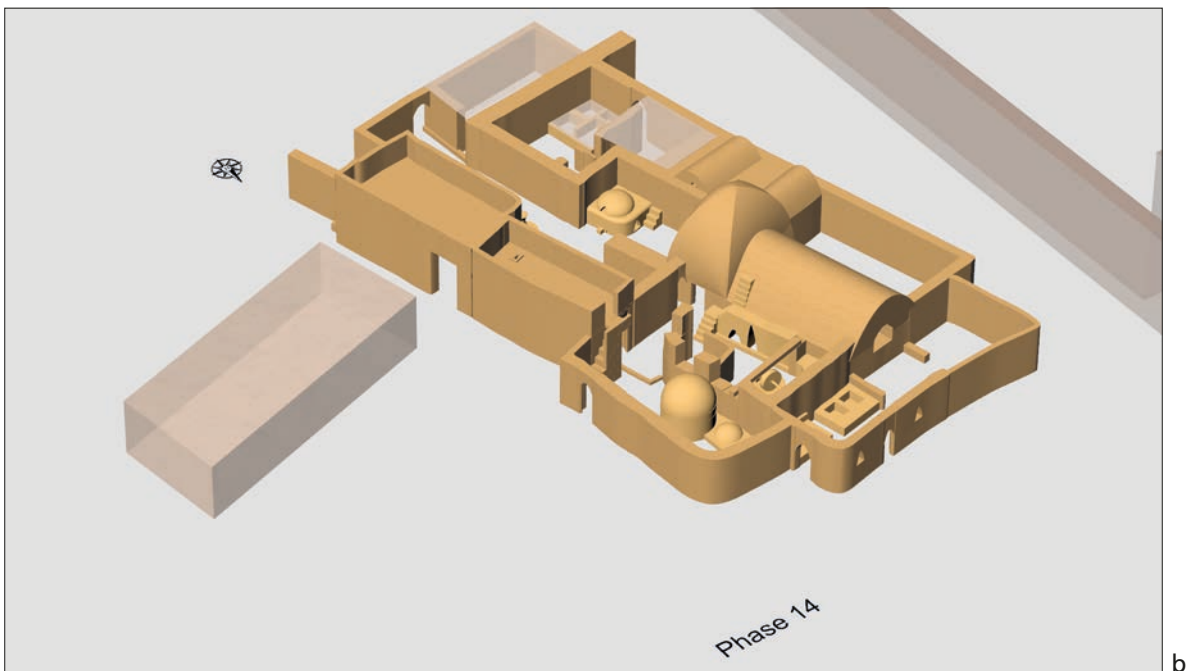

Phase 14 – Rekonstruktionsvorschlag a Grundriss. – b 3D-Modell. – (Plan/Modell K. Czarnitzki/S. Olschok).

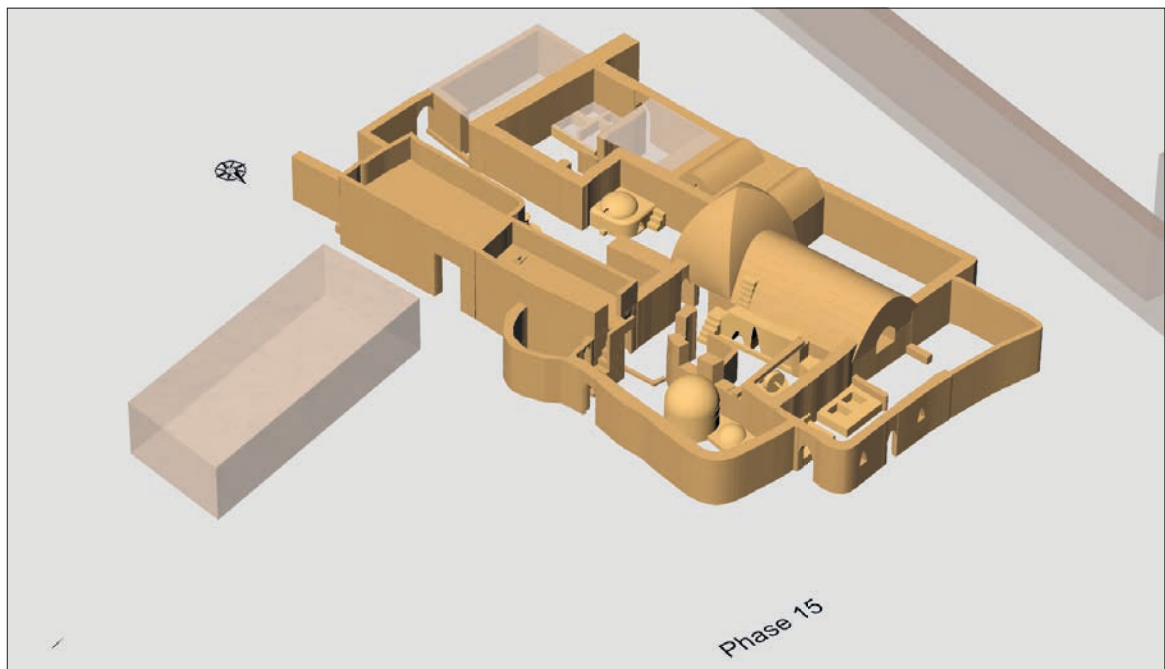

Phase 15 – Rekonstruktionsvorschlag **a** Grundriss. – **b** 3D-Modell. – (Plan/Modell K. Czarnitzki/S. Olschok).



a

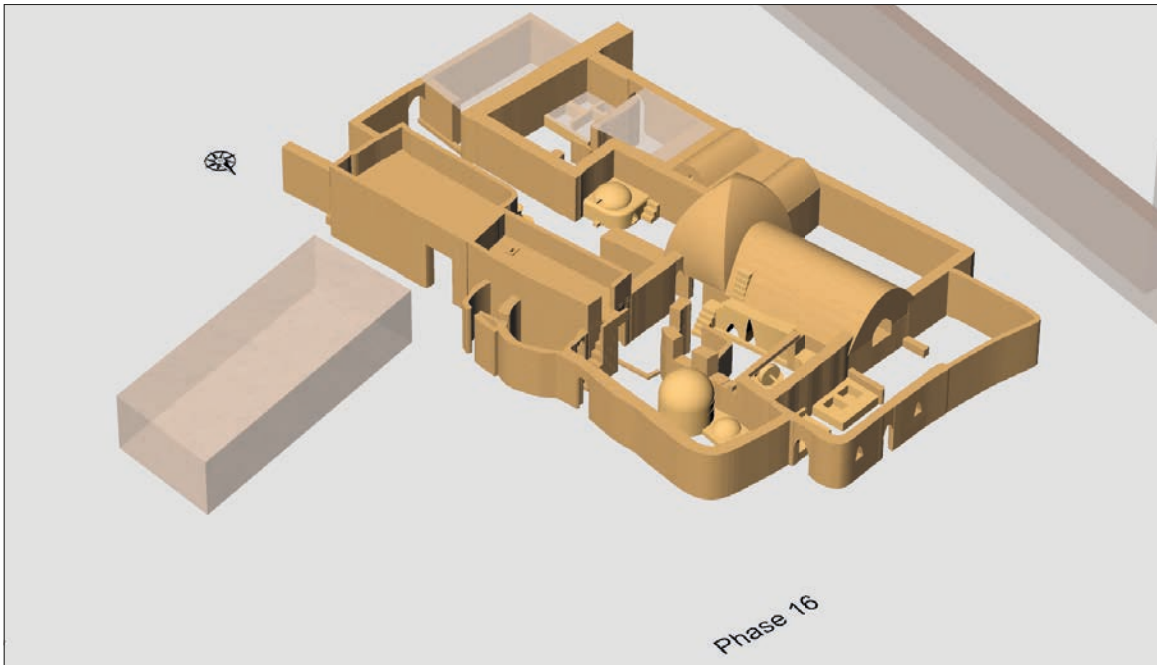

b

Phase 16 – Rekonstruktionsvorschlag **a** Grundriss. – **b** 3D-Modell. – (Plan/Modell K. Czarnitzki/S. Olschok).

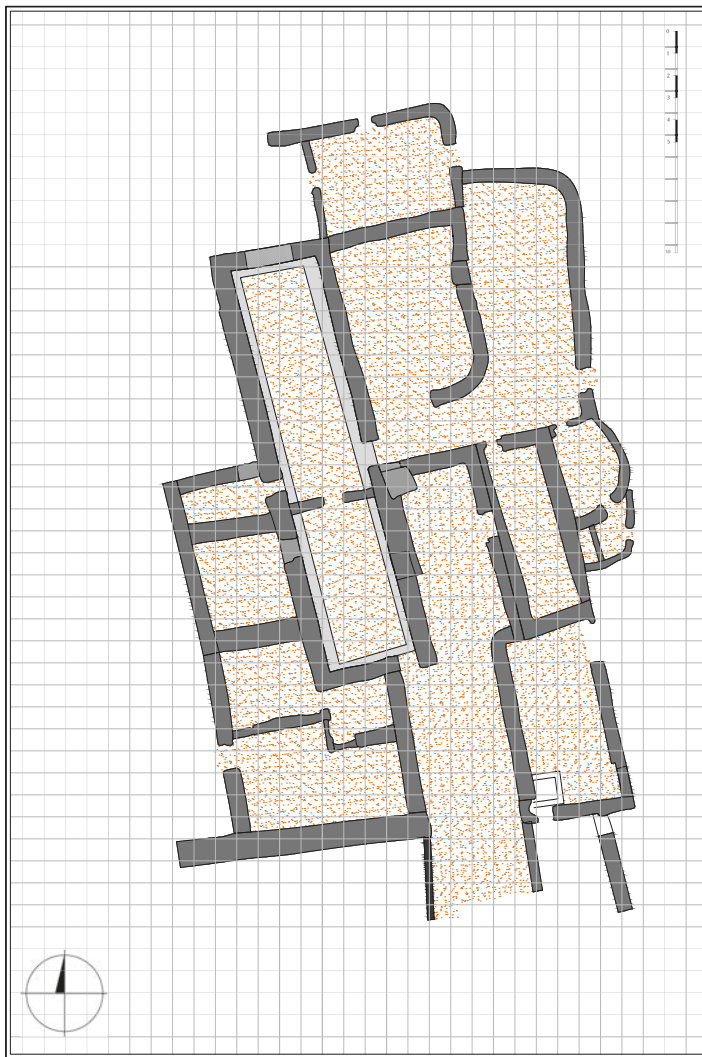

Mauer
 Lehm-/Schutt-
 schichten



Nachnutzungsphasen. **a** Grundriss. – **b** Feuer-/Ofenstelle in OT_83. Blick nach S. – **c** Feuer-/Ofenstelle in OT_84. Blick nach W. – **d** Trog in OT_75. Blick nach O. – **e** Tür zwischen OT_84 und OT_85 mit Spuren einer Lehmziegelmauer. Blick nach S. – (a Plan K. Czarnitzki/S. Olschok; b-e Fotos S. Olschok).