

# Tafeln

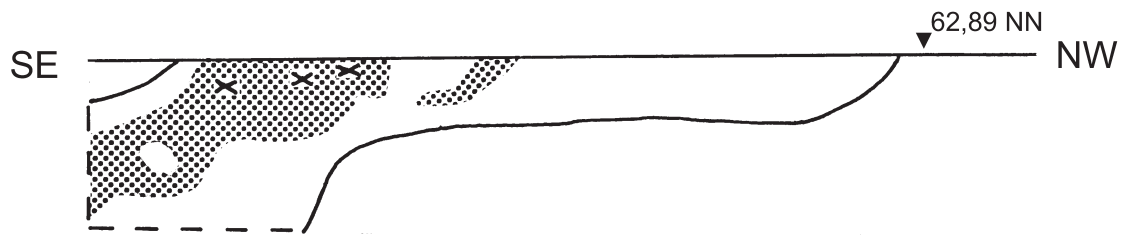





F 116

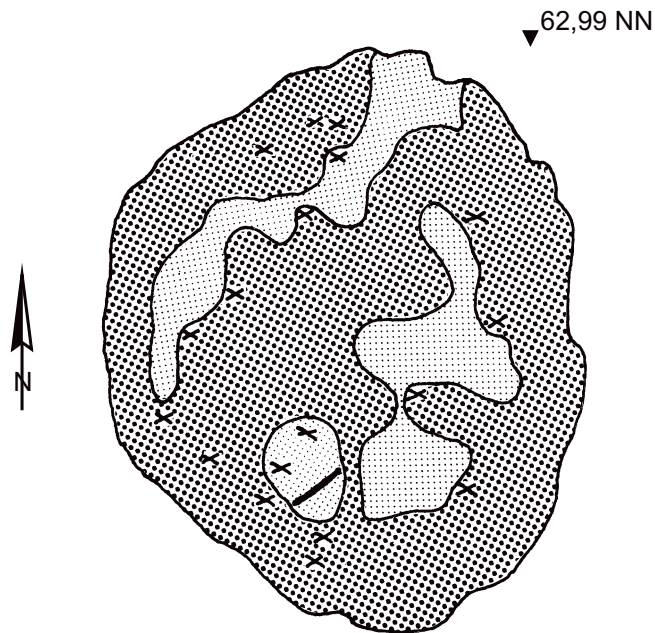
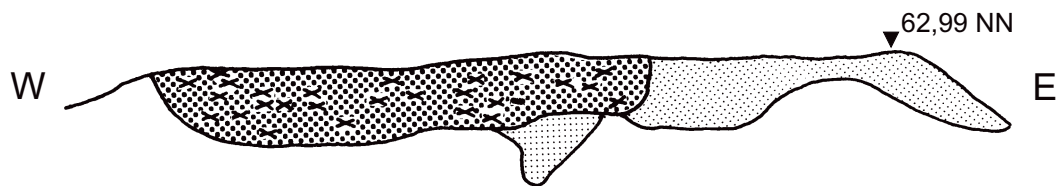

F 119

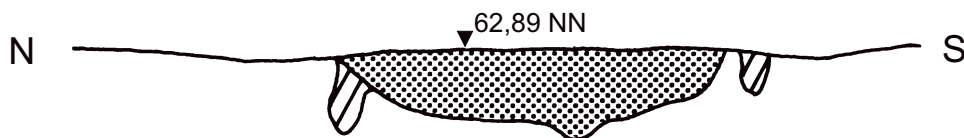

F 154

Tafel 2

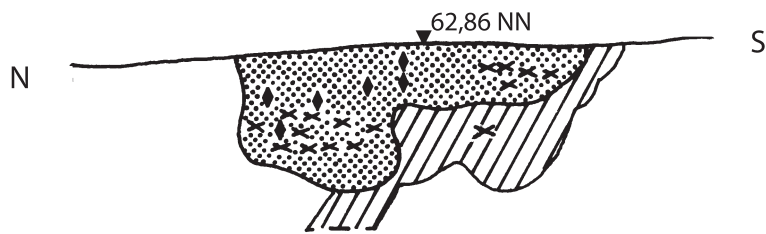

F 155



F 165

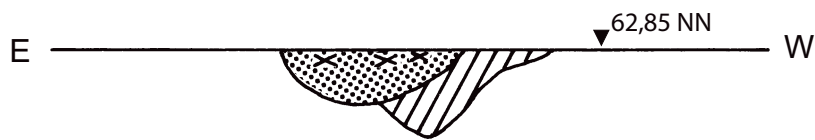

F 171

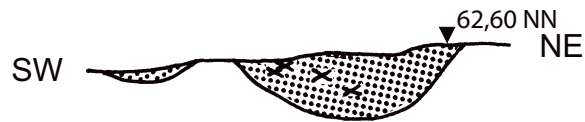

F 175

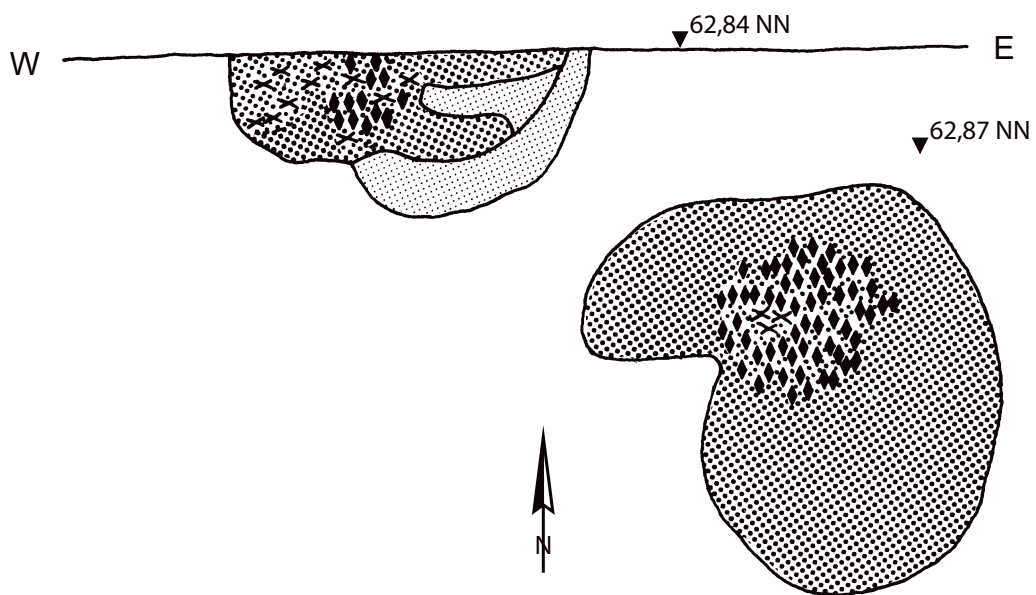

F 235

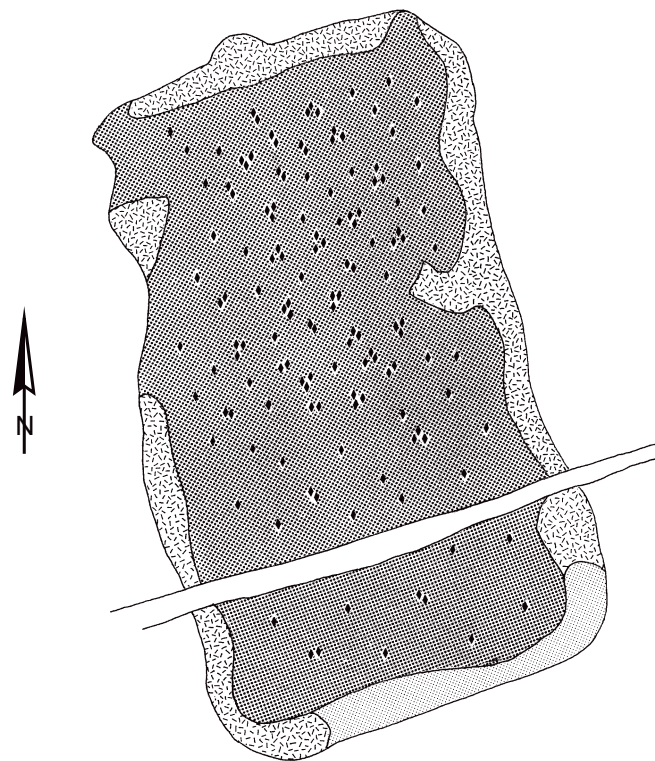

F 232

Tafel 4

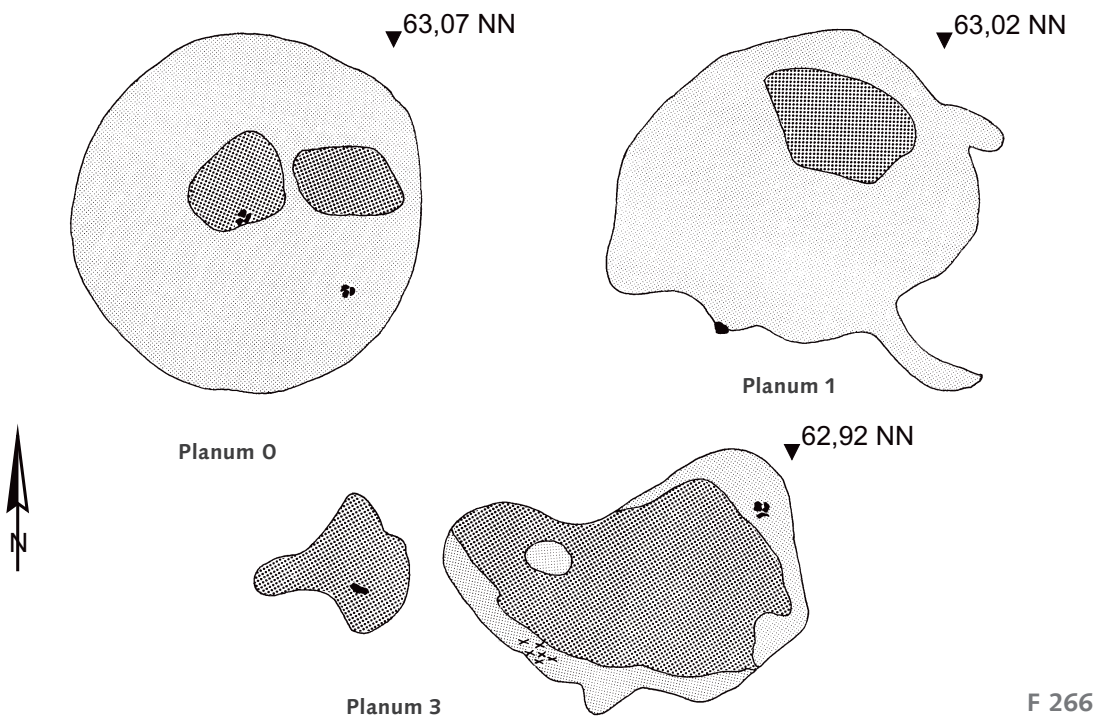
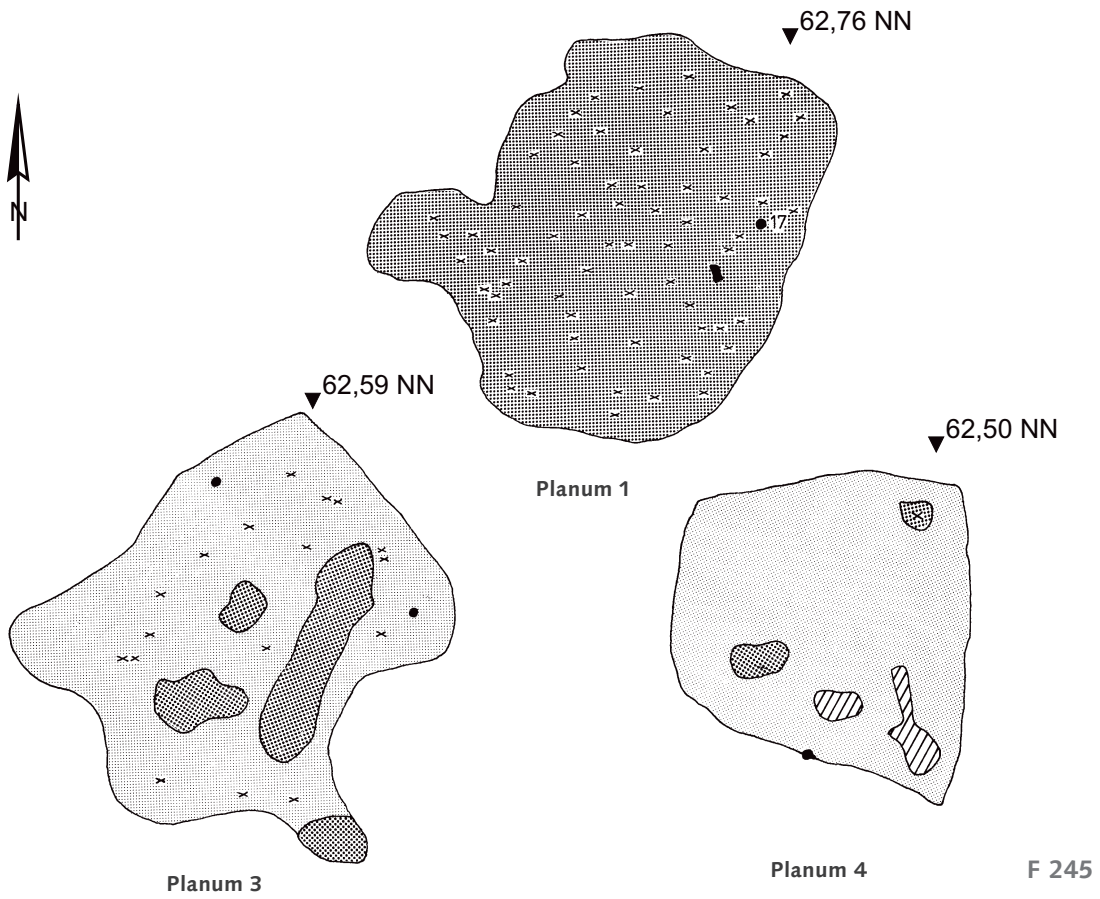



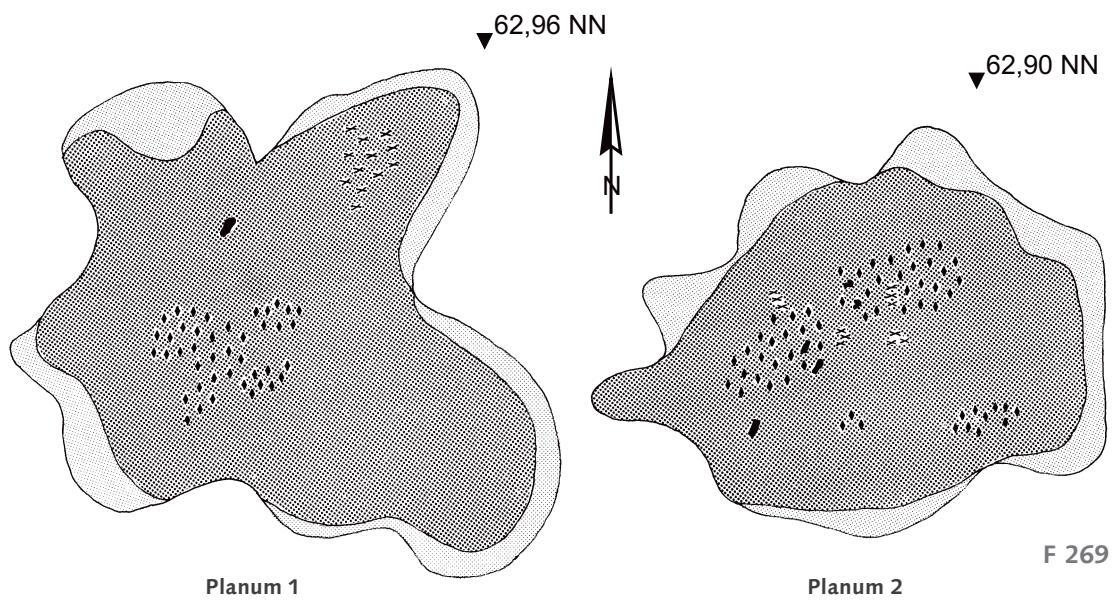
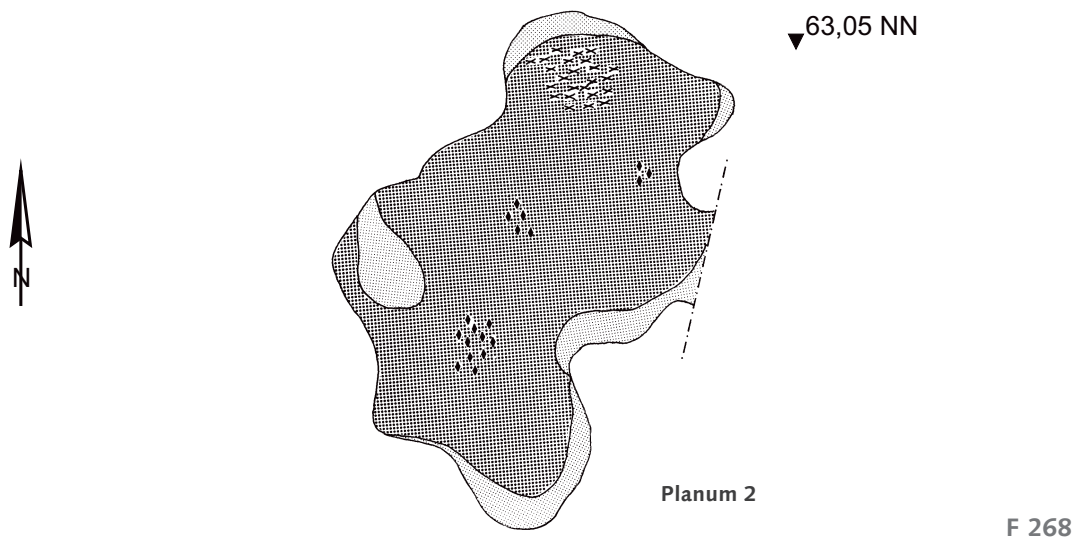
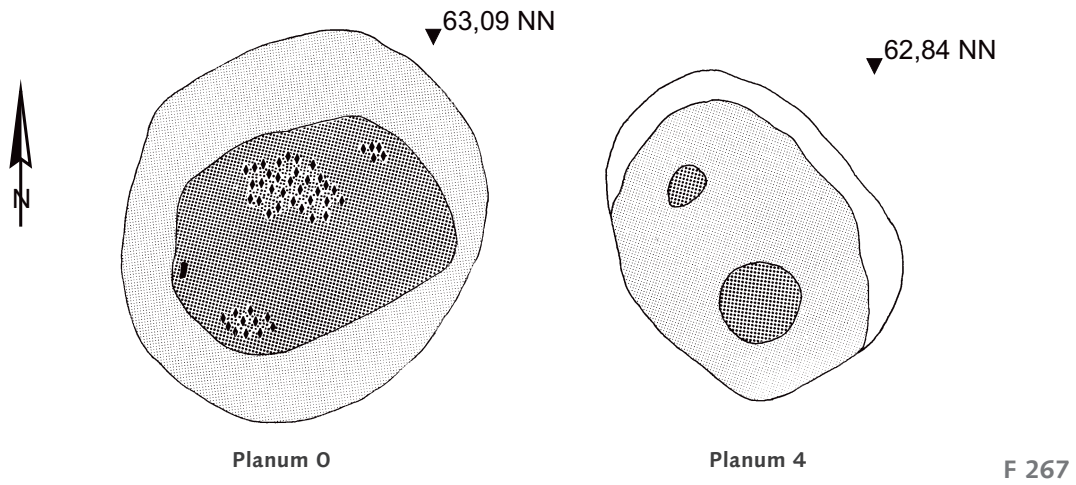

Tafel 6

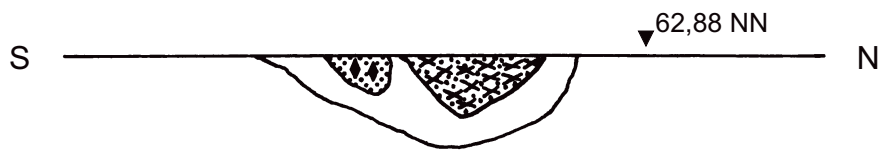

F 274

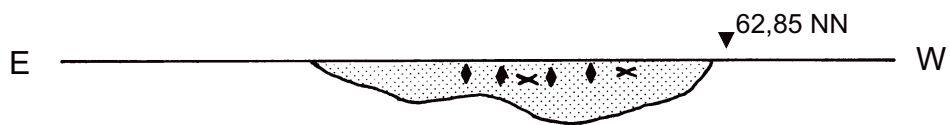

F 305

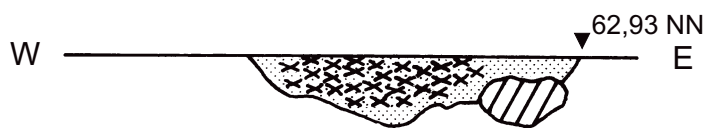

F 306

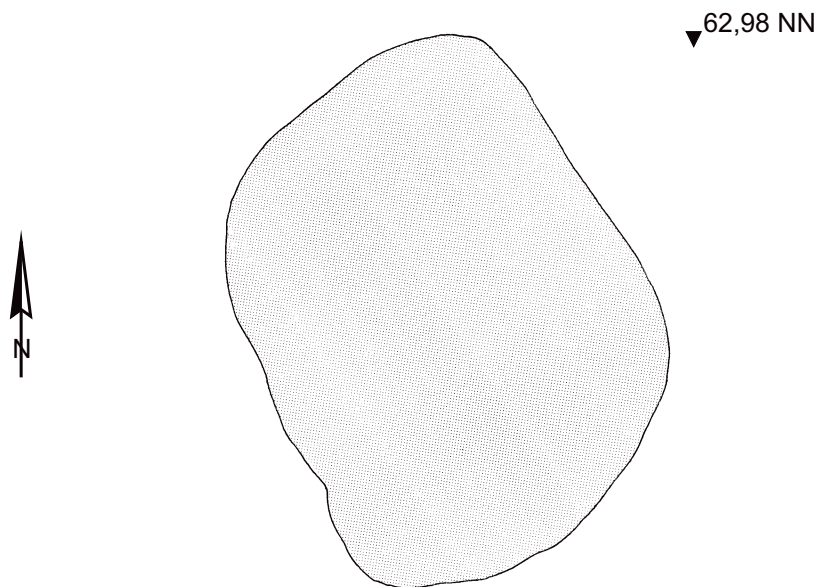

Planum O

F 307

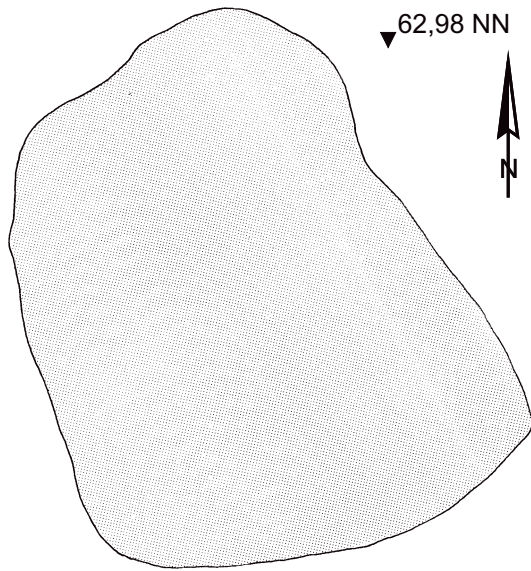

Planum 0

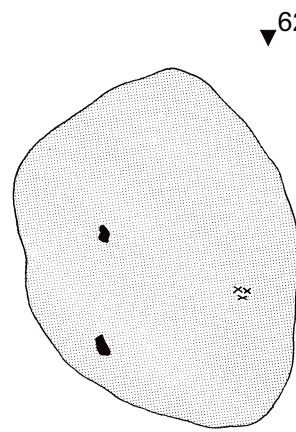

Planum 3

F 308

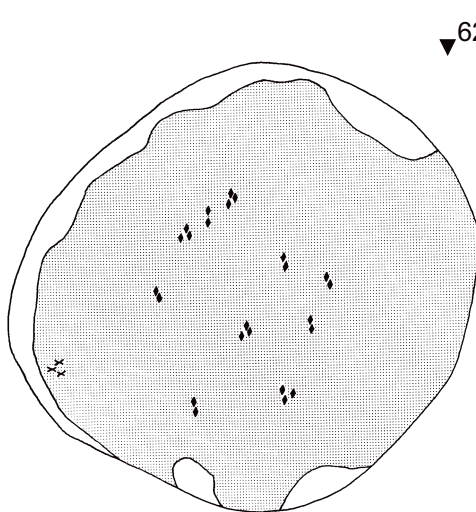

Planum 0

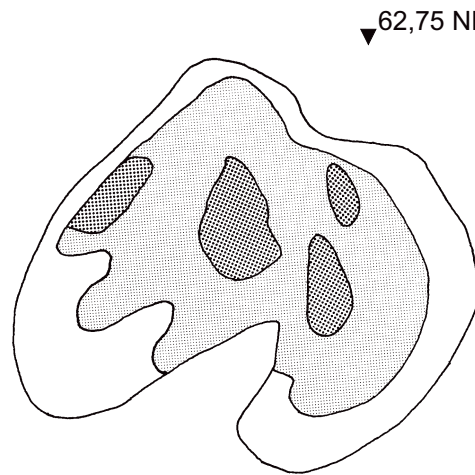

Planum 2

F 310

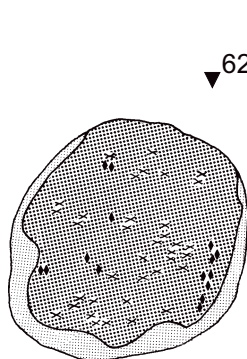

Planum 0

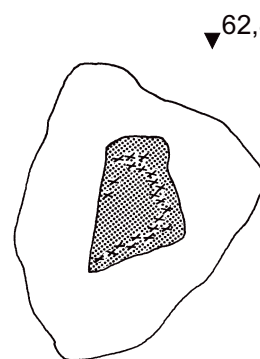

Planum 1

F 311

Tafel 8

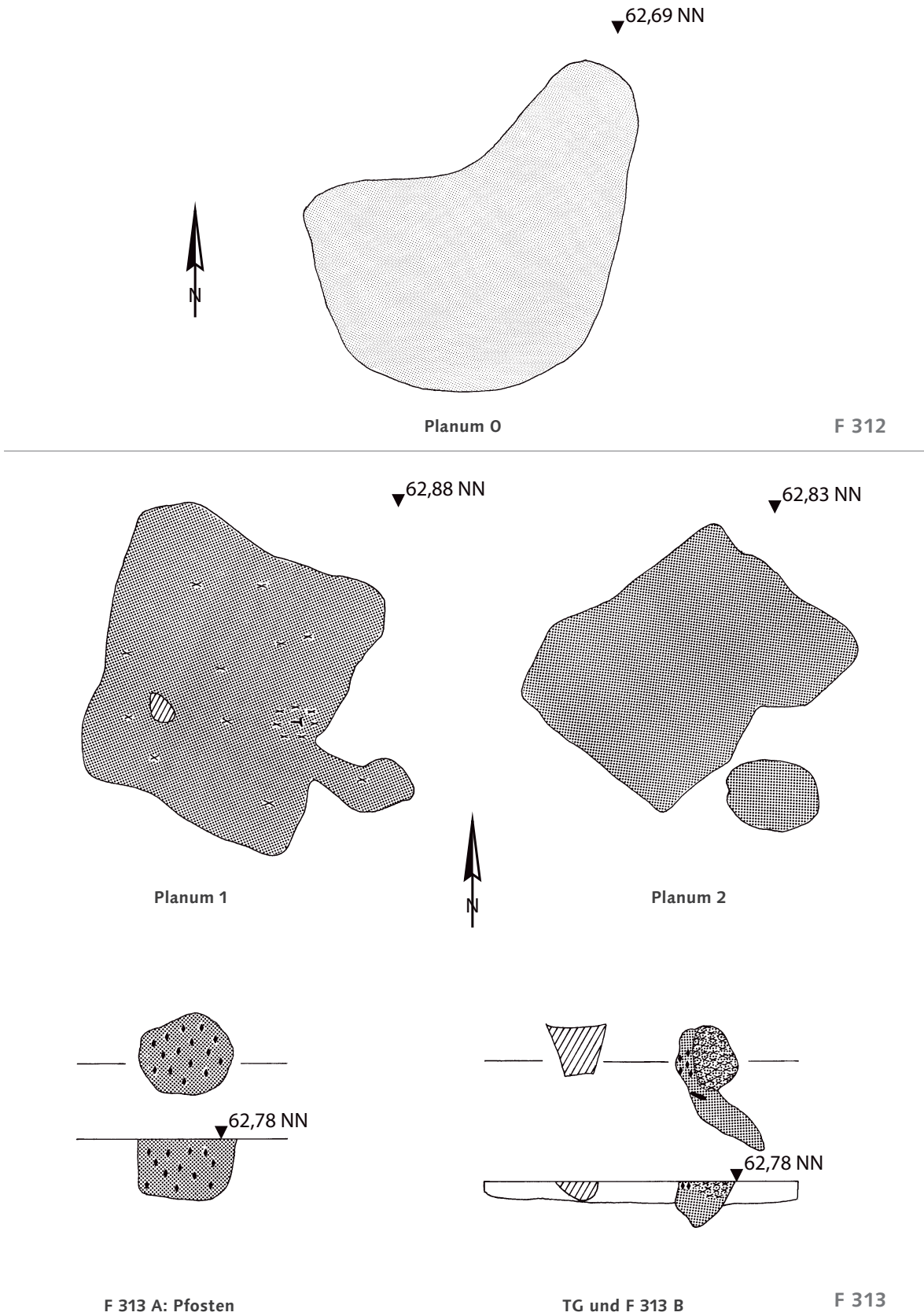



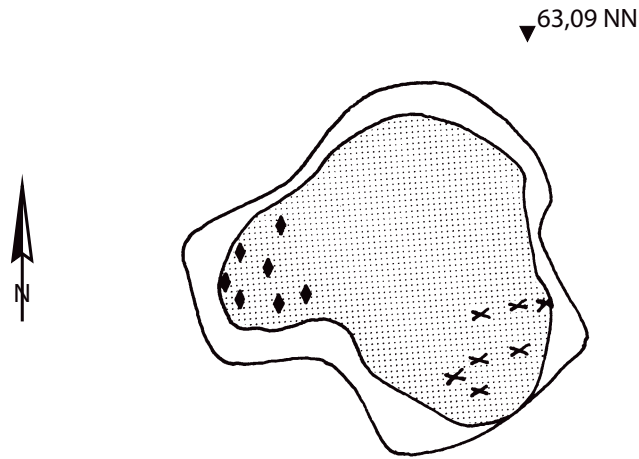

F 314

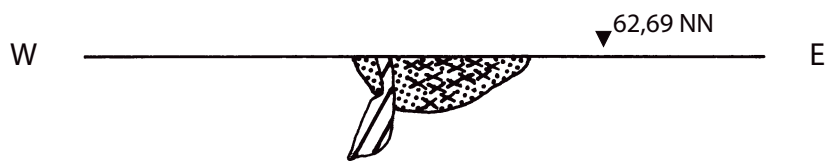

F 315

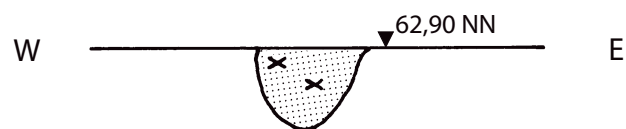

F 317

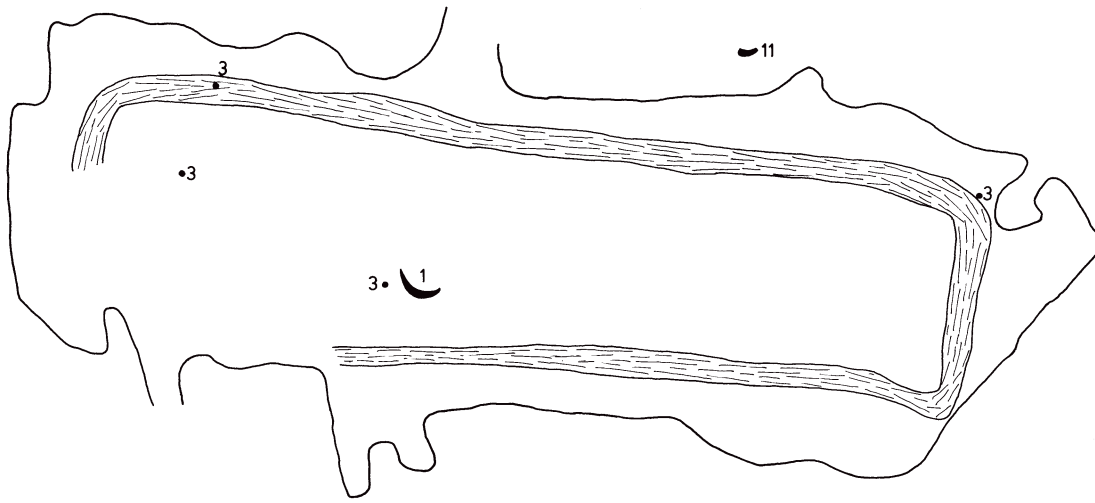

Planum 1

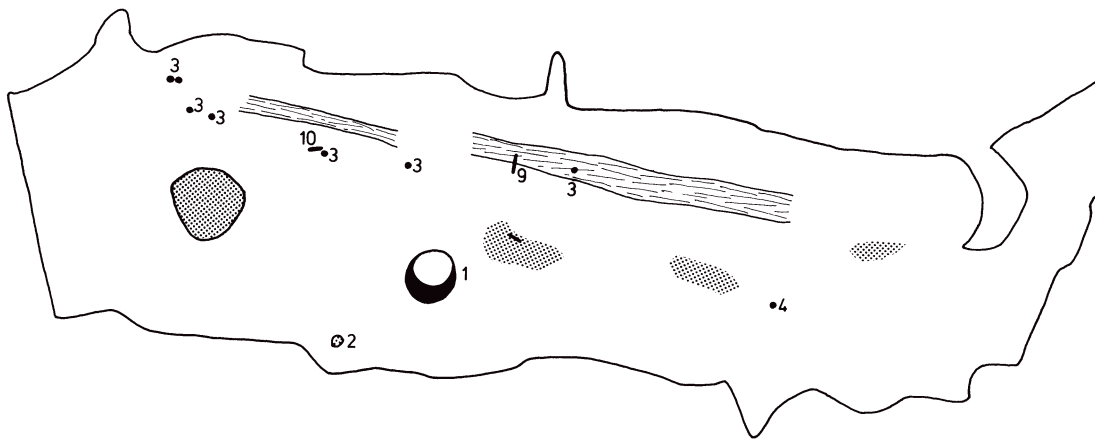

Planum 3

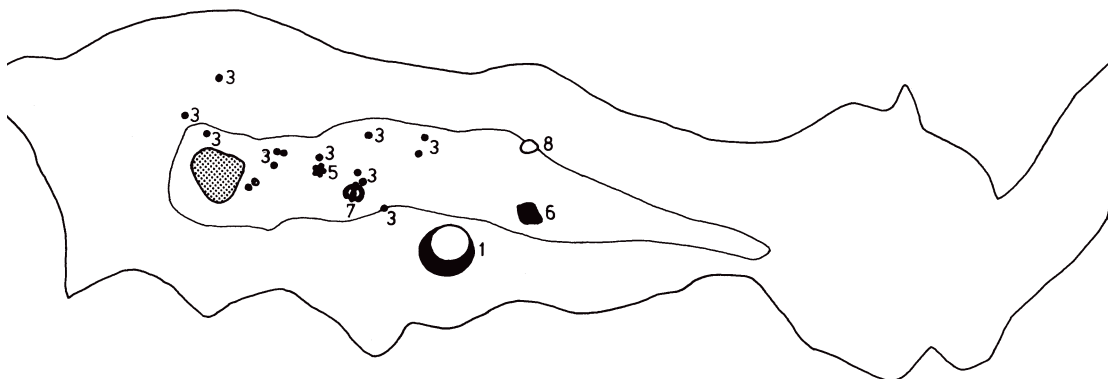

Planum 4

F 108

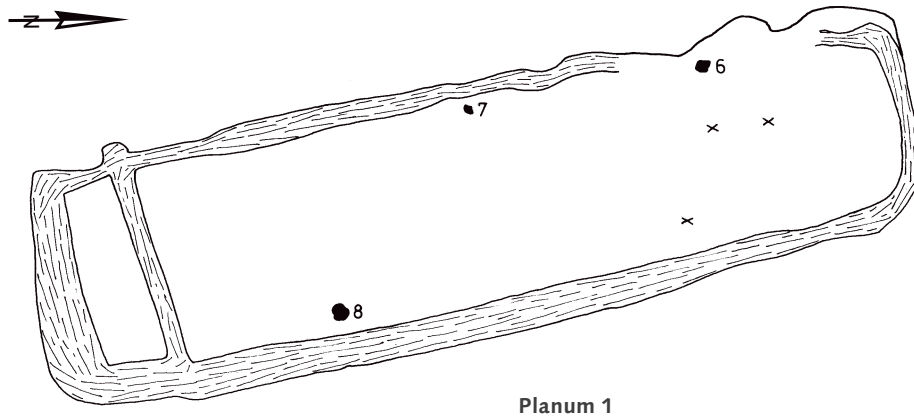

Planum 1

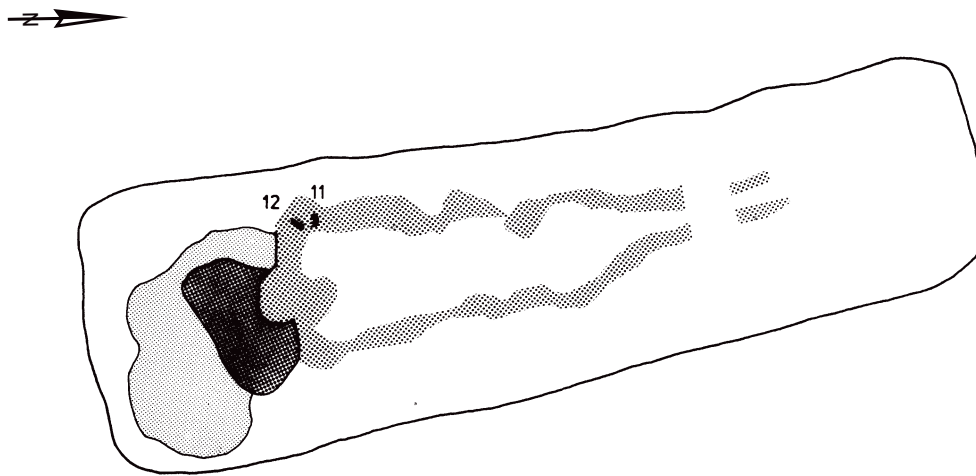

Planum 5

F 115

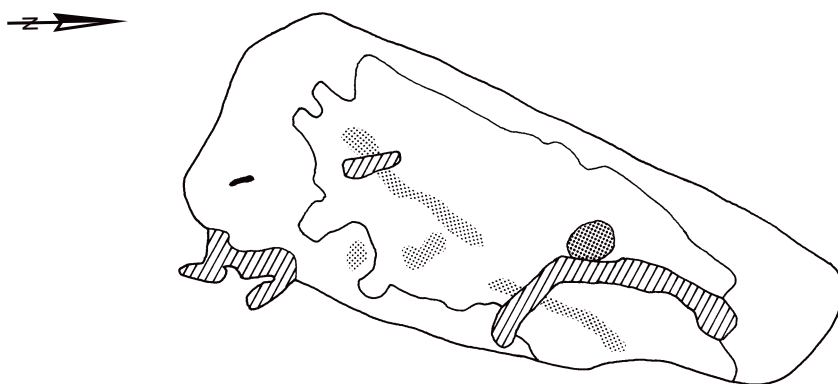

Planum 2

F 216

Tafel 12

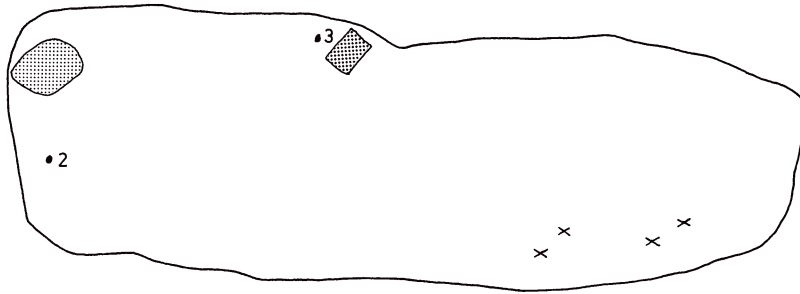

Planum 3

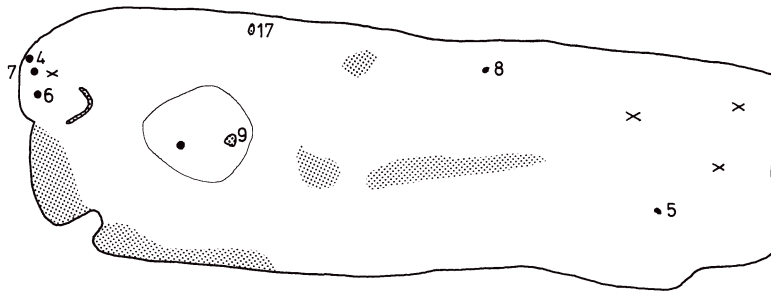

Planum 4

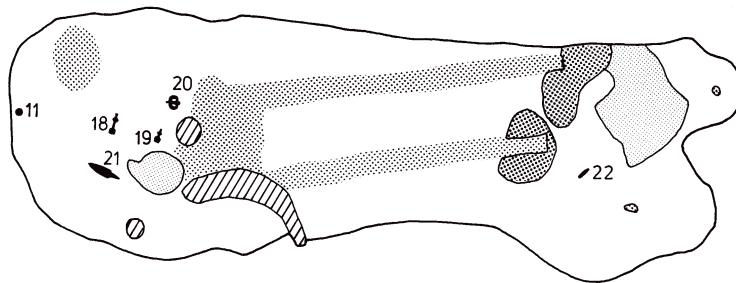

Planum 5

F 182

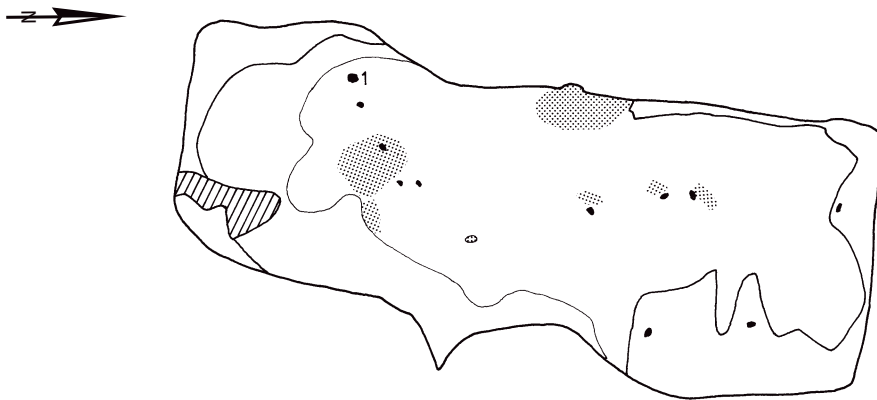

Planum 2

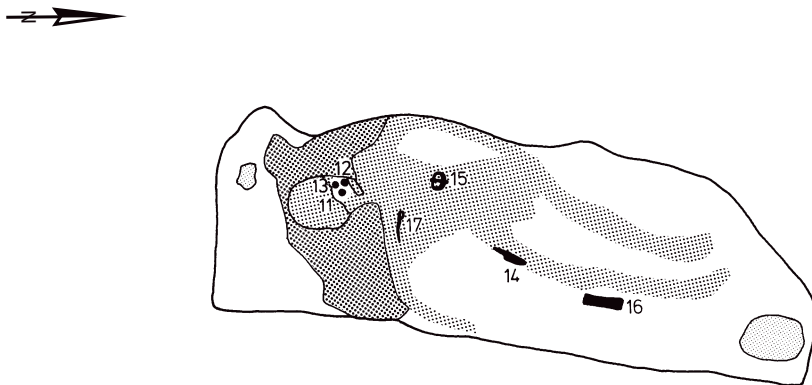

Planum 5

F 183

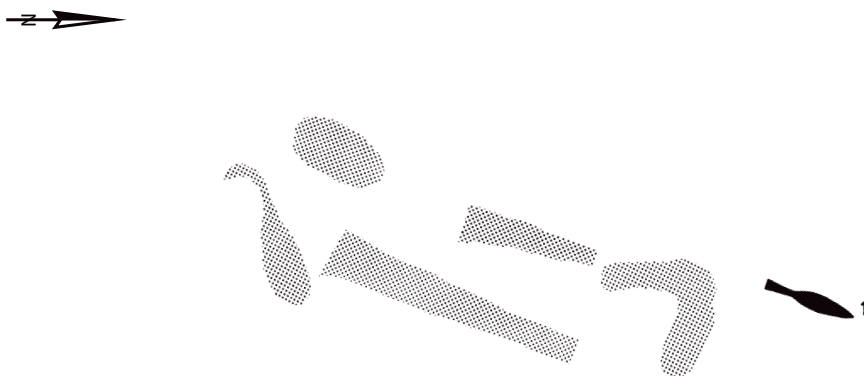

F 316

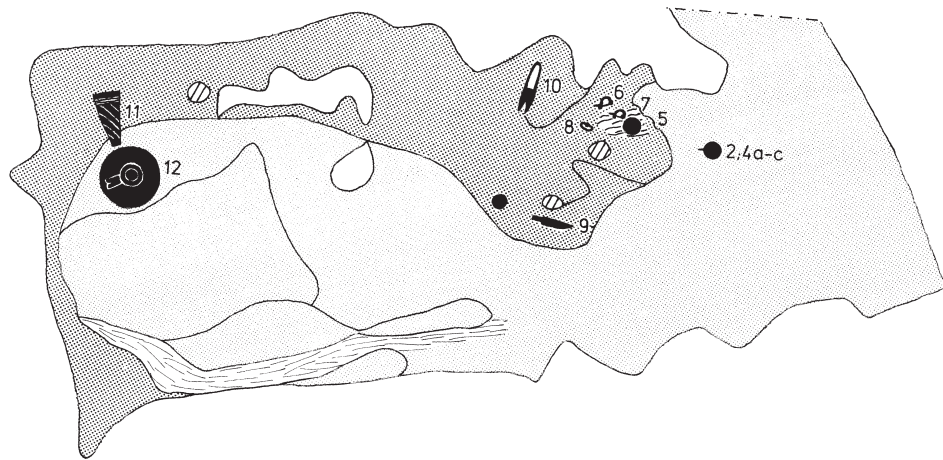

Planum 1

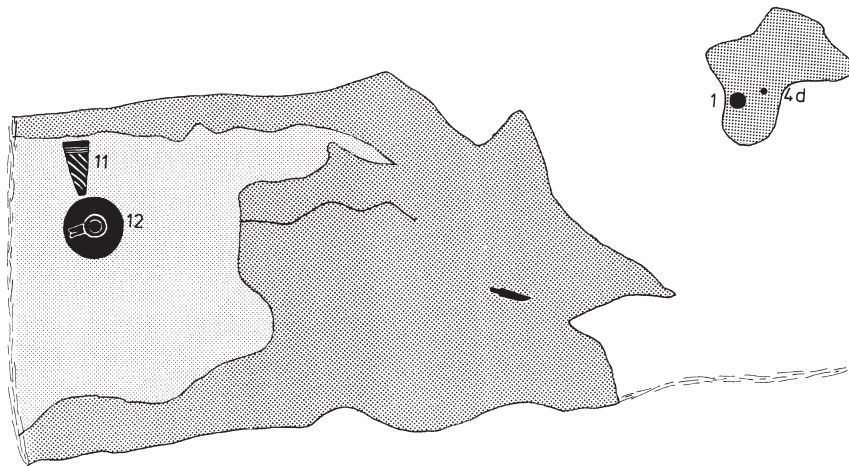

Planum 2

F 318



√62.42 NN

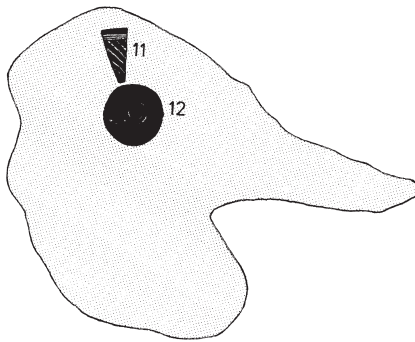

Planum 5

Planum 3

F 318

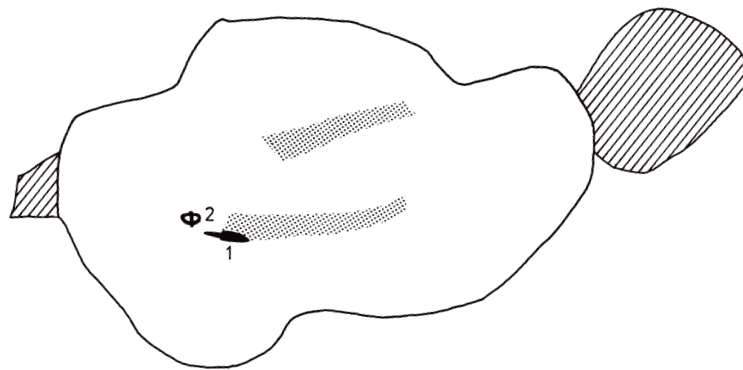

Planum 1

F 319

Tafel 16

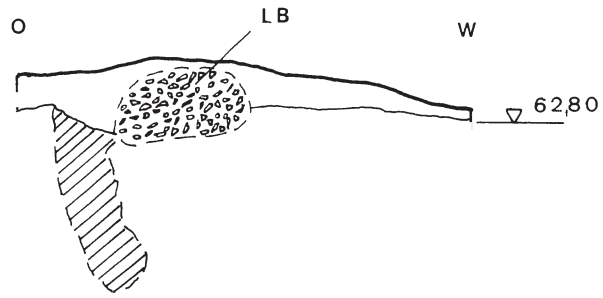

F 1

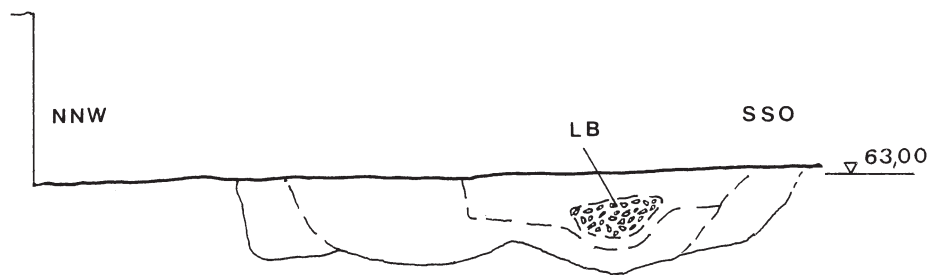

F 4

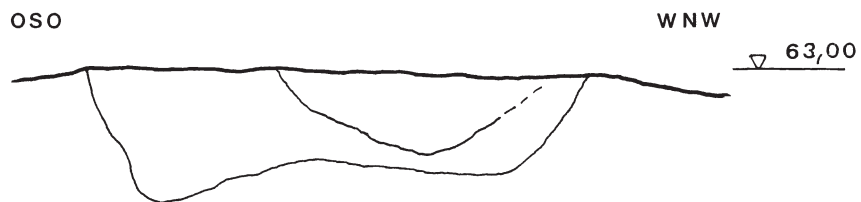

F 5

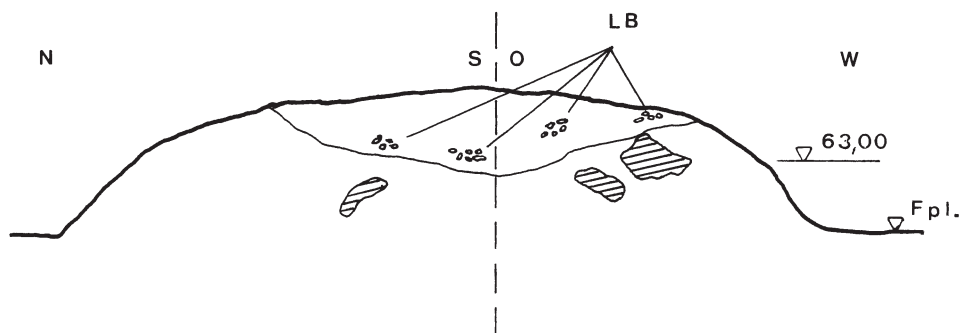

F 6





F 7

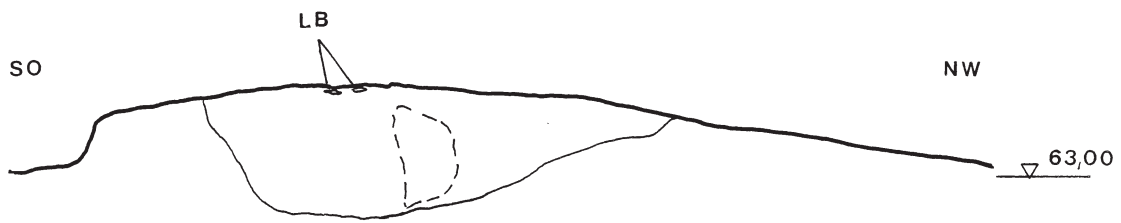

F 8



F 9

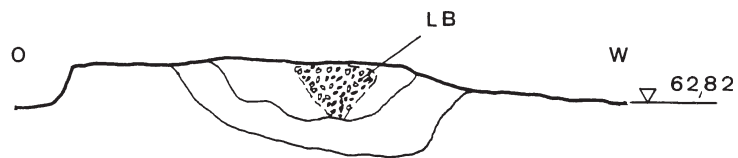

F 10

# Tafel 18

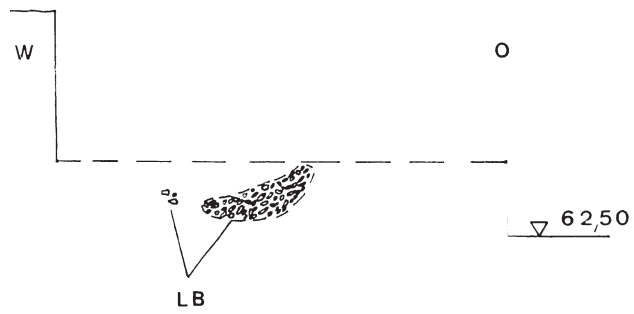

F 12

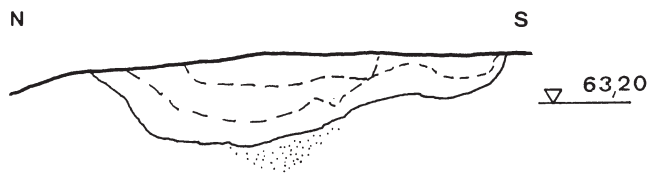

F 15

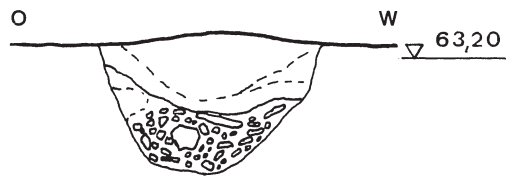

F 16



F 16a



F 17

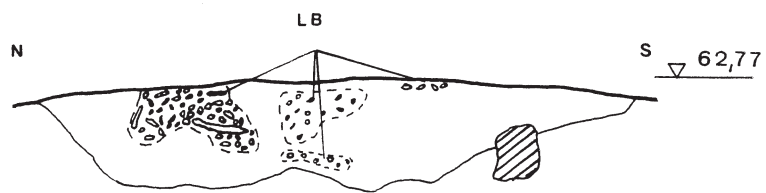

F 18

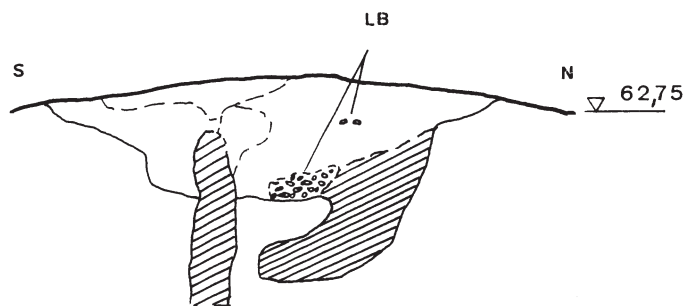

F 19

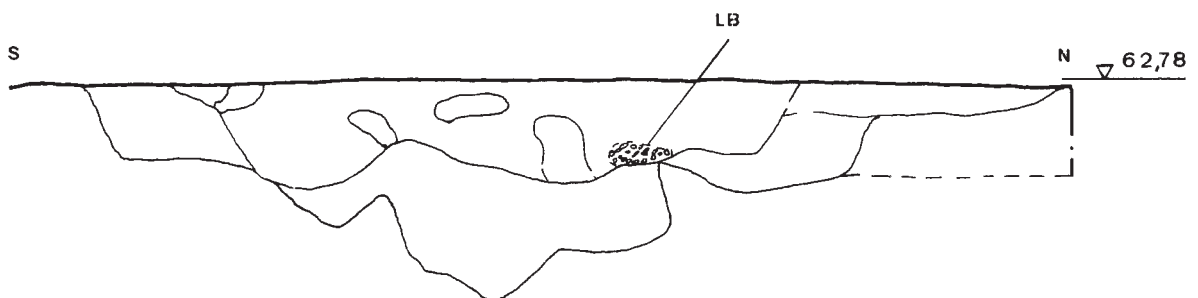

F 20

Tafel 20

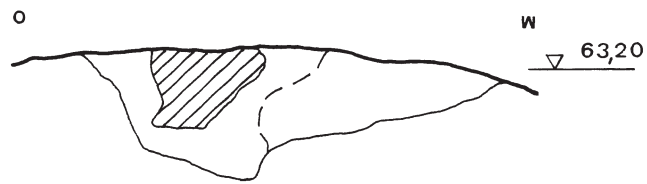

F 21

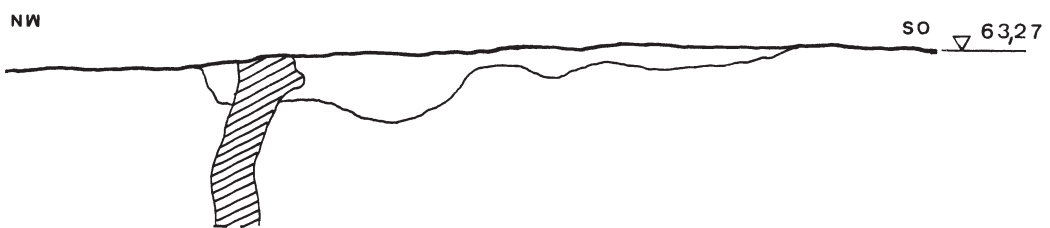

F 22

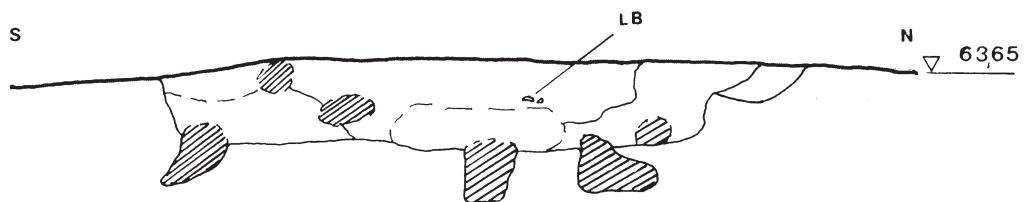

F 23



F 24

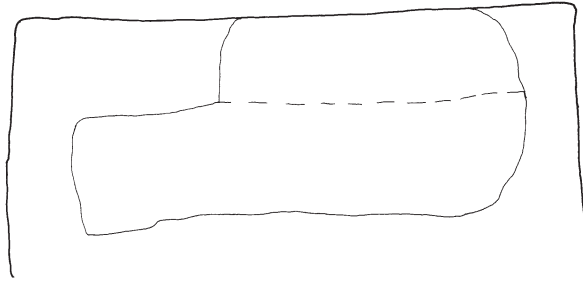

Planum 2

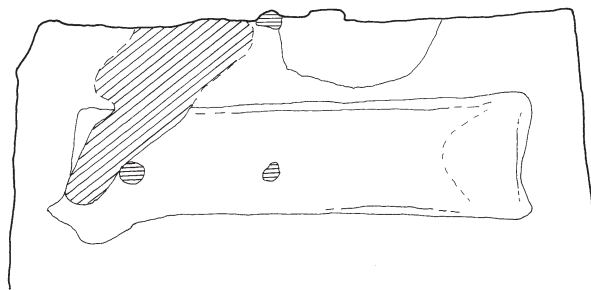

Planum 3

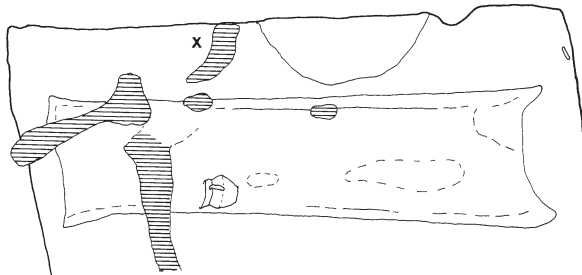

Planum 4

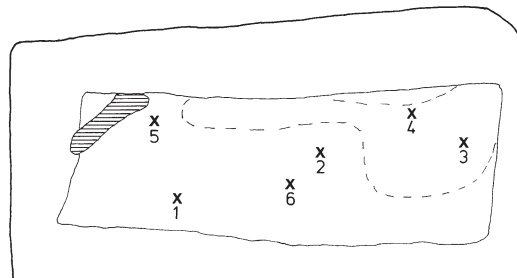

Planum 5

F 26

Tafel 22

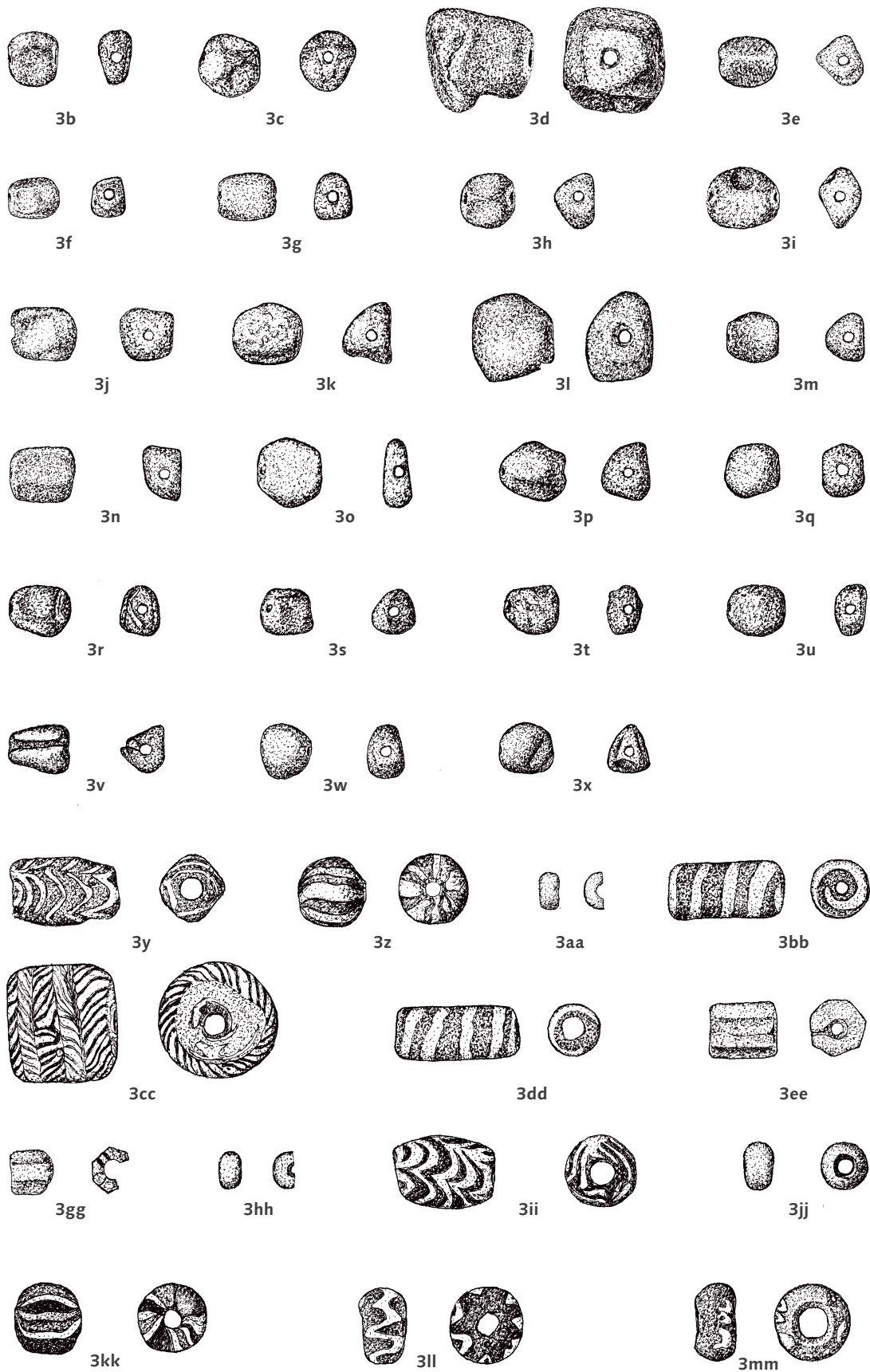

F 108

Beelen. Körpergrab F 108. 3b–3x: Bernsteinperlen. 3y–3ee, 3gg–3mm: Glasperlen. – Alles Maßstab 1:1.

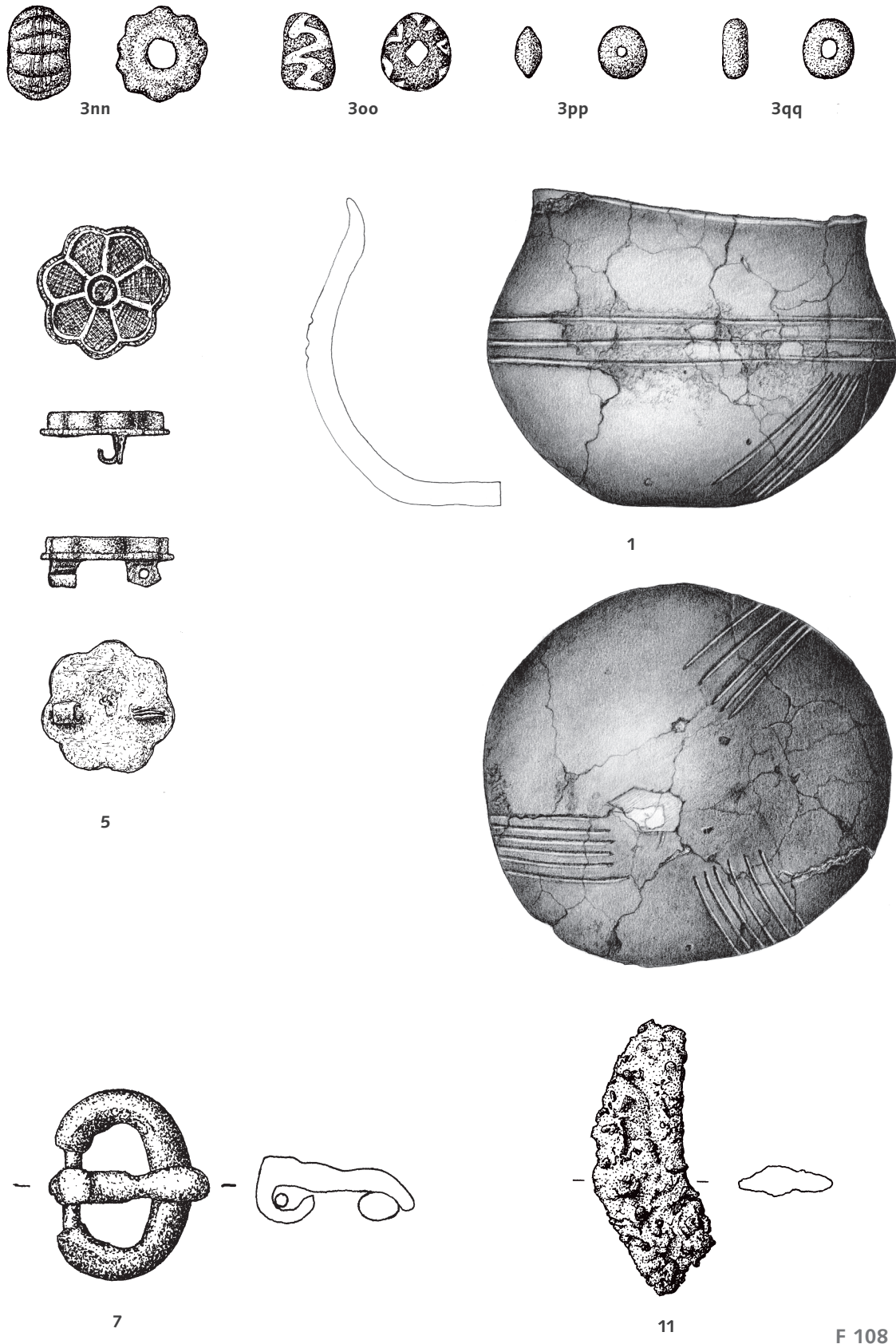

Beelen. Körpergrab F 108. 1: Keramikgefäß mit eingesetzter Glasscherbe im Boden. 3nn–3qq: Glasperlen. 5: Silberne, teilweise vergoldete Scheibenfibel mit Granateinlagen. 7: Bronzeschnalle. 11: Eisenfragment (Messer?). – 1: Maßstab 1:2. 3nn–3qq, 5, 7, 11: Maßstab 1:1.

Tafel 24



3

6



7



9

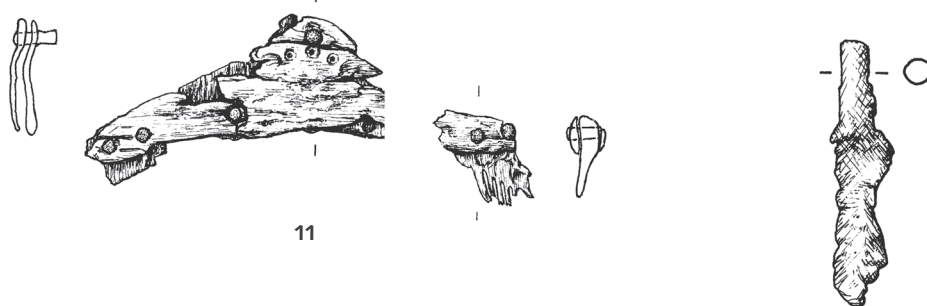

11

12

F 115



1

6



5

7

F 119

Beelen. Körpergrab F 115. 3, 6, 7, 9: Keramik. 11: Beinkamm. 12: Eisenstift. Brandgrab F 119. 1, 6: Keramik. 5: Eisenstift. 7: Beinkammfragmente. – Alles Maßstab 1:1.



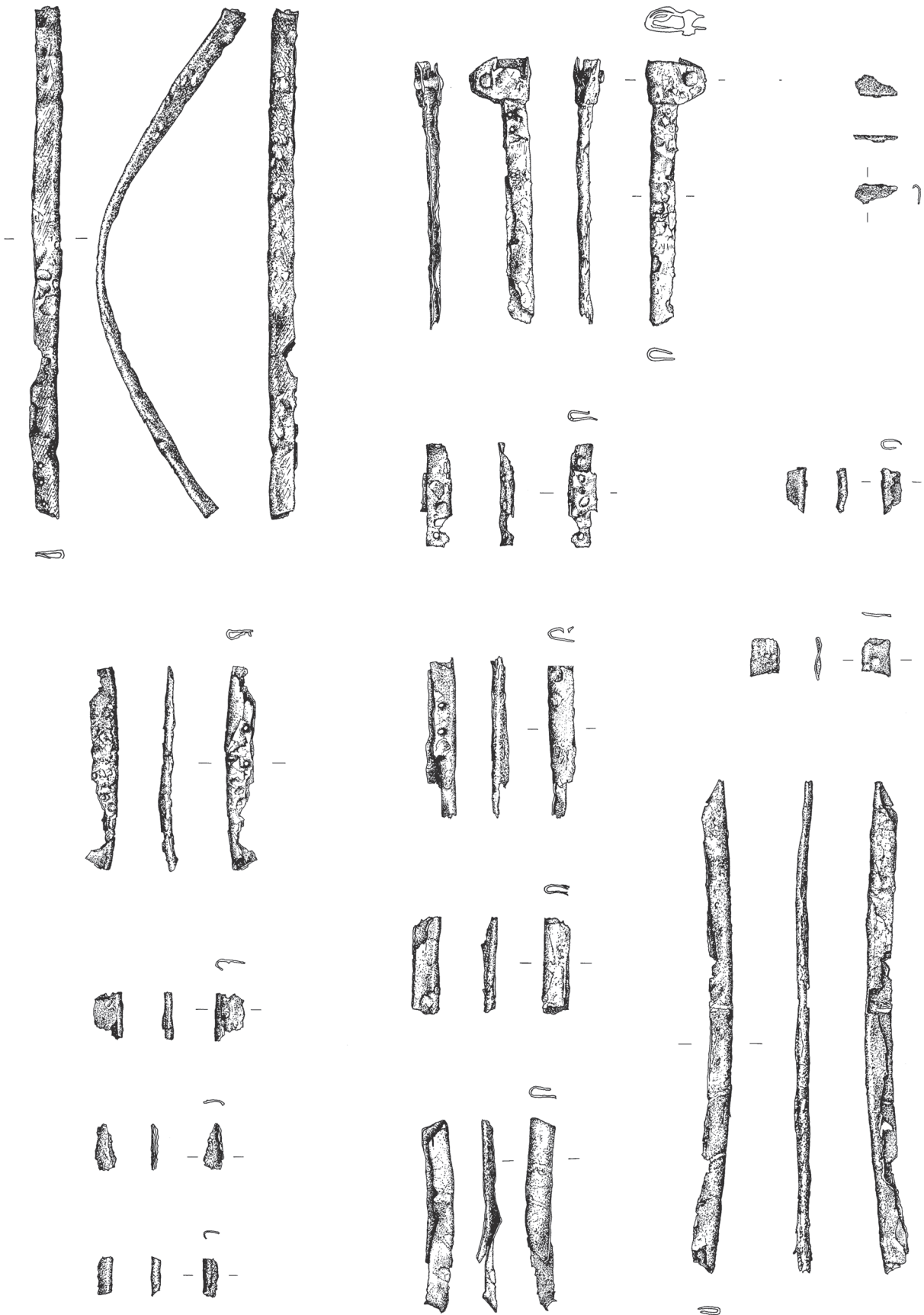

Beelen. Brandgrab F 119. 4: Eiserne Schildrandbeschläge. – Maßstab 1:2.

Tafel 26

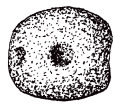

4



6



7



10

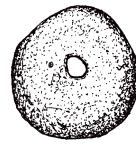

11

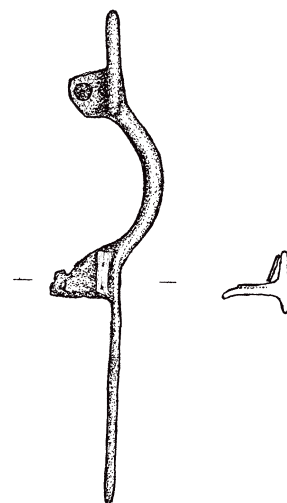
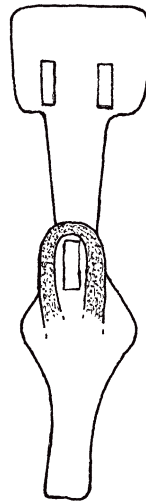
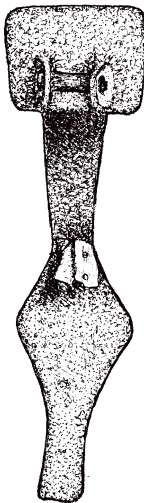

18

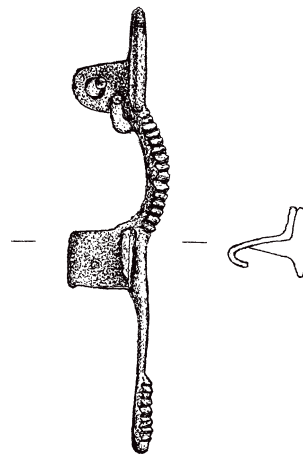
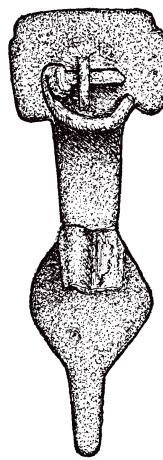
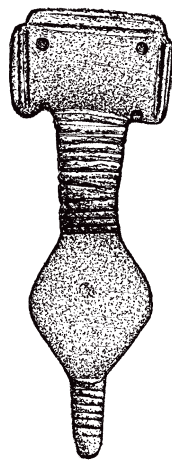

19

F 182

Beelen. Körpergrab F 182. 4, 6, 11: Bernsteinperlen. 7: Glasperle. 10: Glasgefäßscherbe. 18, 19: Bronzene Bügelfibeln. – Alles Maßstab 1:1.

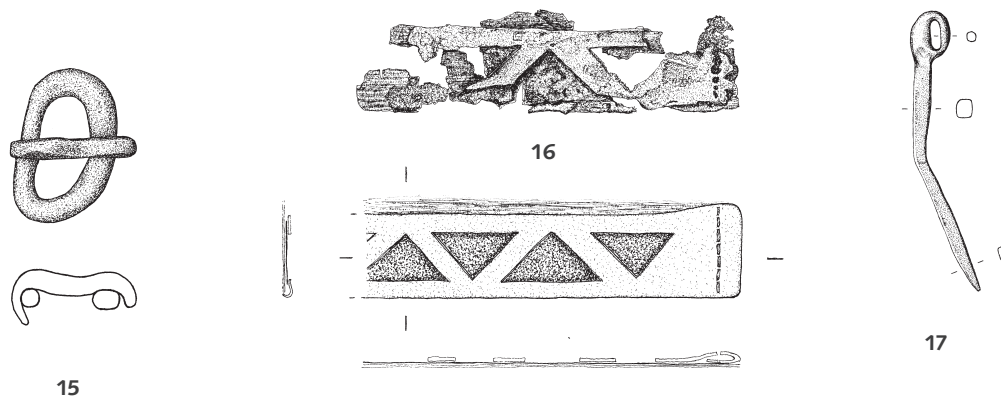
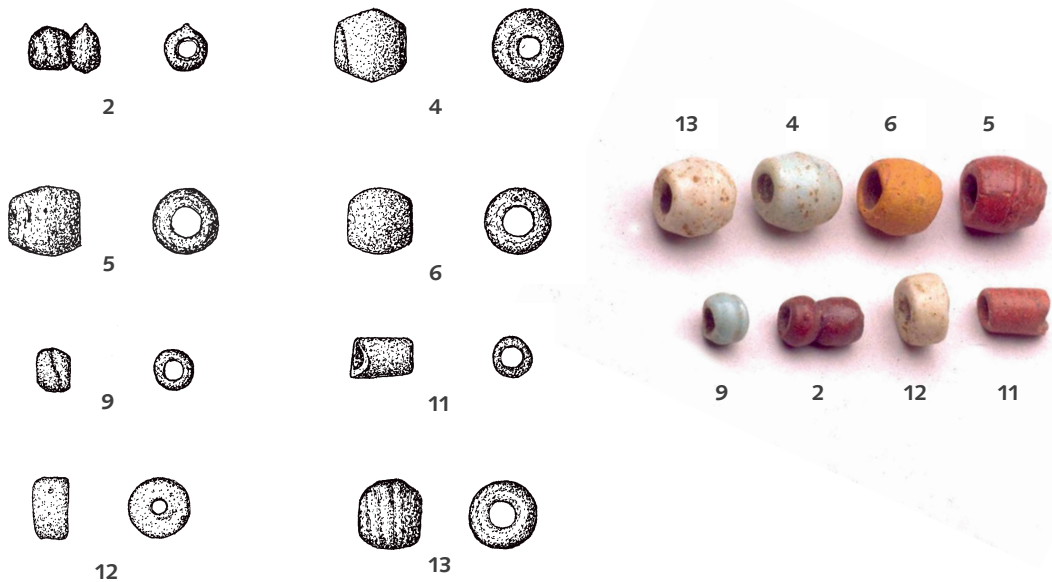
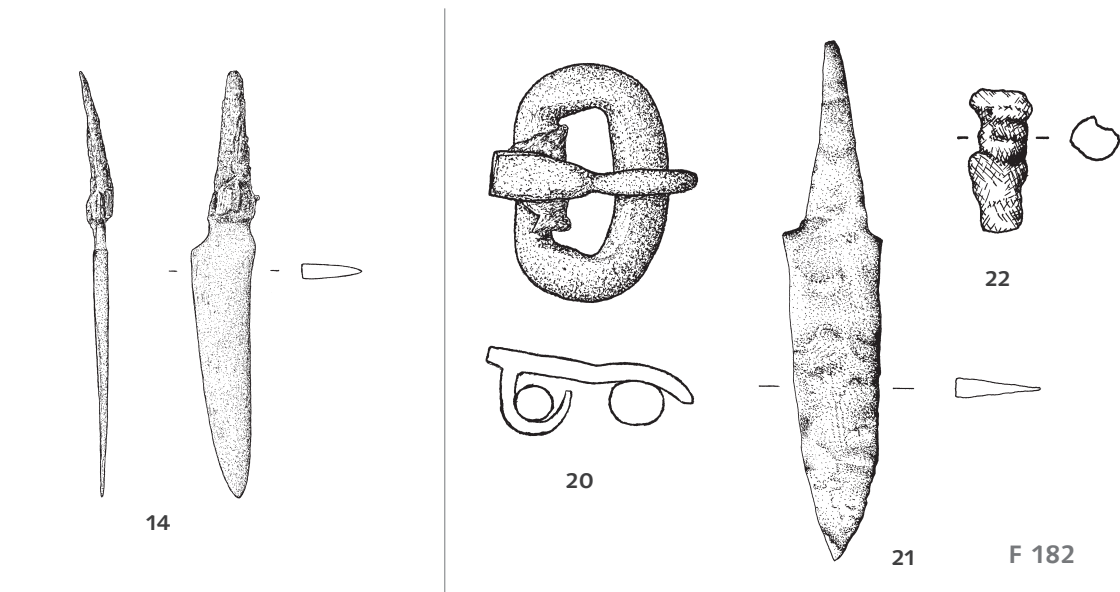

Beelen. Körpergrab F 182. 20: Bronzeschnalle. 21: Eisenmesser. 22: Eisenstift. – 20, 22: Maßstab 1:1. 21: Maßstab 1:2. Körpergrab F 183. 2, 4–6, 9, 11–13: Glasperlen. 14: Eisenmesser. 15: Eisenschnalle. 16: Borte (Leder, Bronzeblech, Rinde). 17: Eisennadel. – Perlen: Maßstab 1:1. 14–17: Maßstab 1:2. Foto o. Maßstab.

Tafel 28

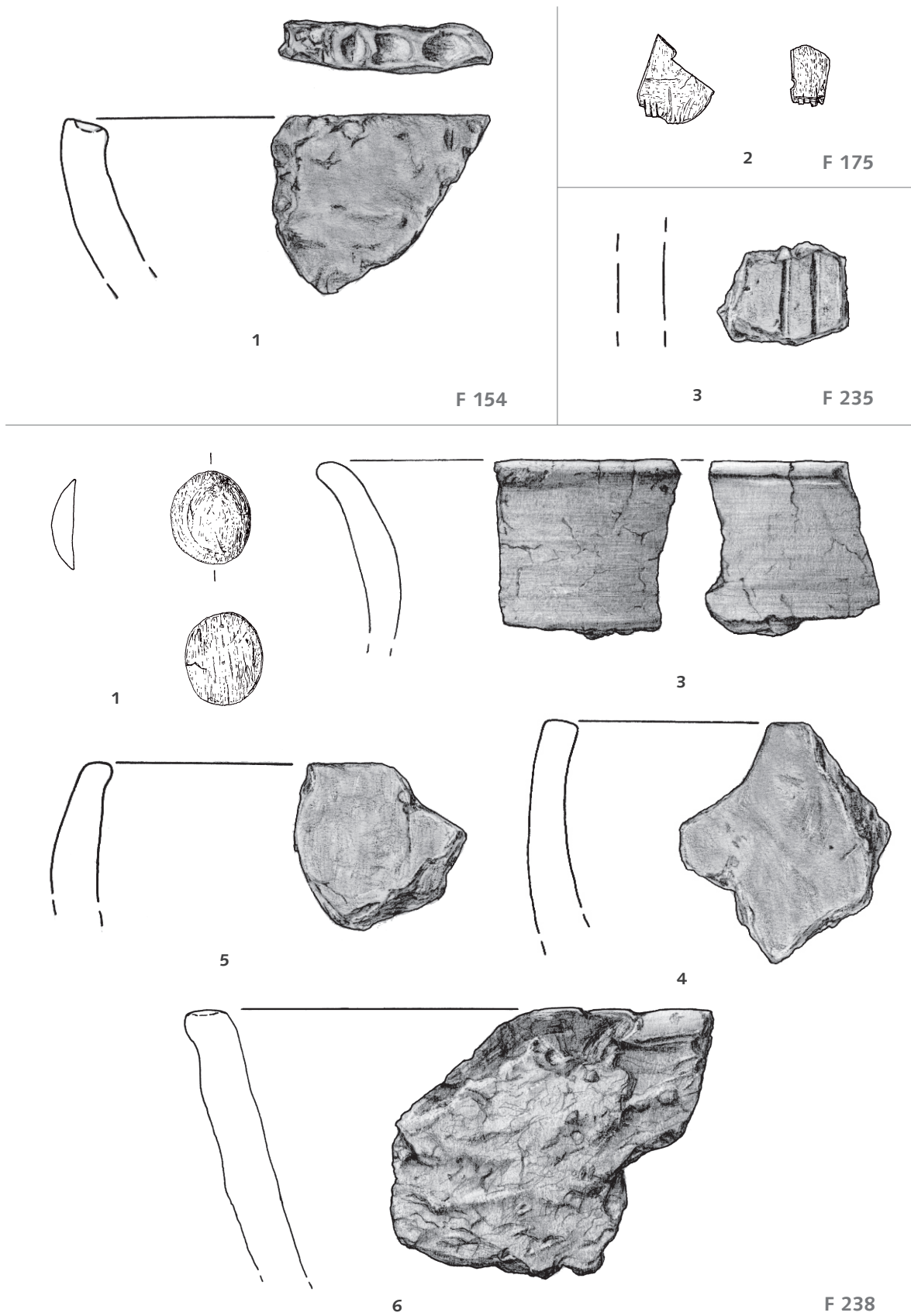

Beelen. Brandgrab F 154. 1: Keramik. Brandgrab F 175. 2: Beinkammfragmente. Brandgrab F 235. 3: Keramik. Befund F 238. 1: Beispielstein. 3-6: Keramik. – Alles Maßstab 1:1.

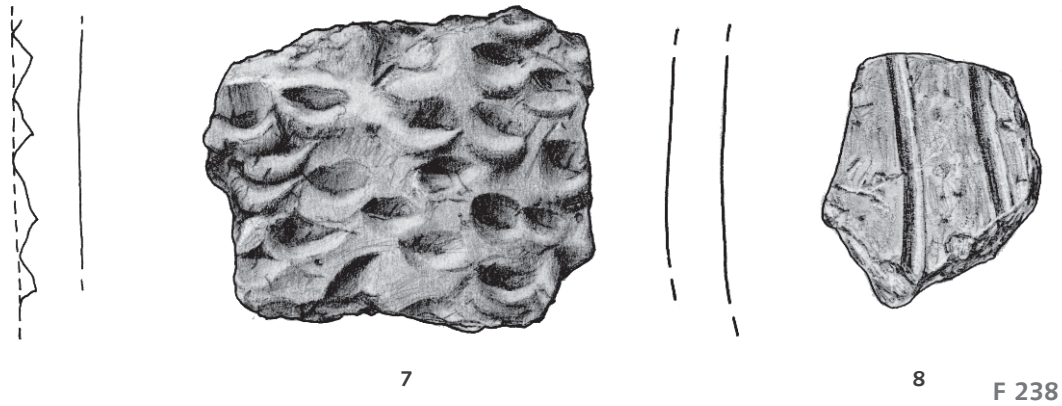

7

8

F 238

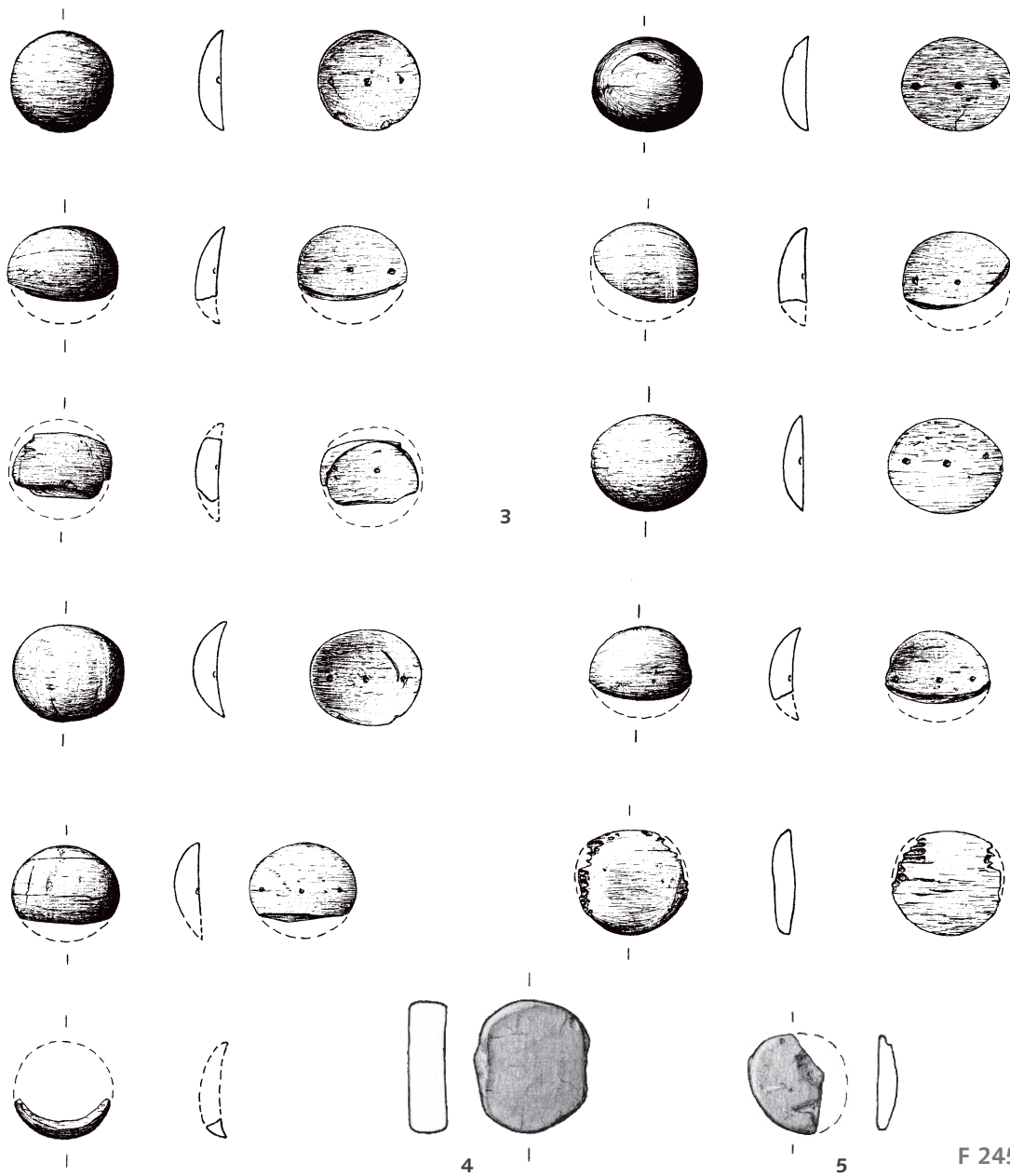

3

4

5

F 245



Tafel 30

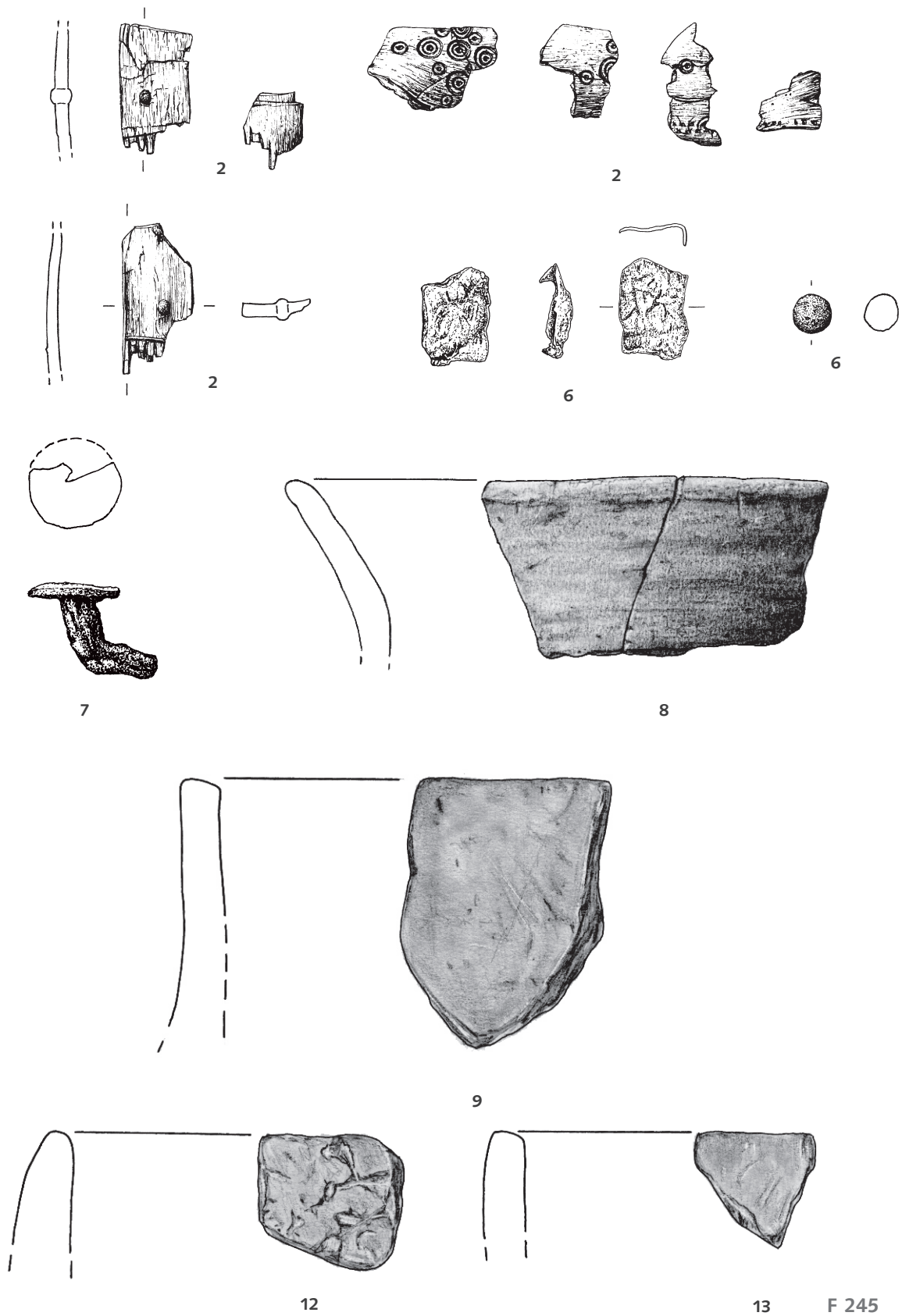

Beelen. Brandgrab F 245. 2: Beinkammfragmente. 6: Bronzeschmelz. 7: Eisennagel. 8, 9, 12, 13: Keramik. – Alles Maßstab 1:1.

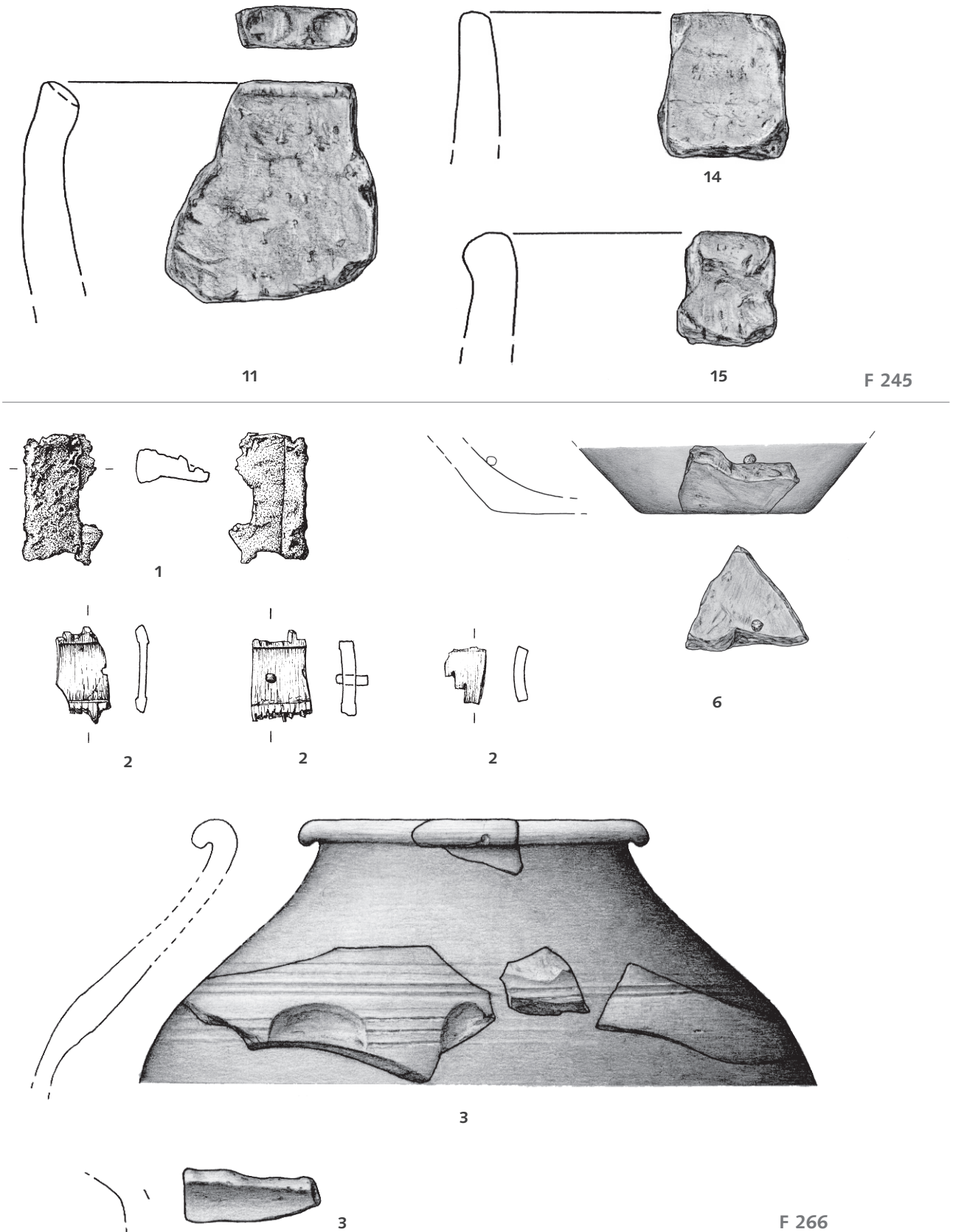

Beelen. Brandgrab F 245. 11, 14, 15: Keramik. – Maßstab 1:1. Brandgrab F 266. 1: Bronzeschmelz. 2: Beinkammfragmente. 3, 6: Keramik (6 mit anhaftendem Bronzeschmelzkügelchen). – 1, 2, 3: Maßstab 1:1. 6: Maßstab 1:2.

Tafel 32

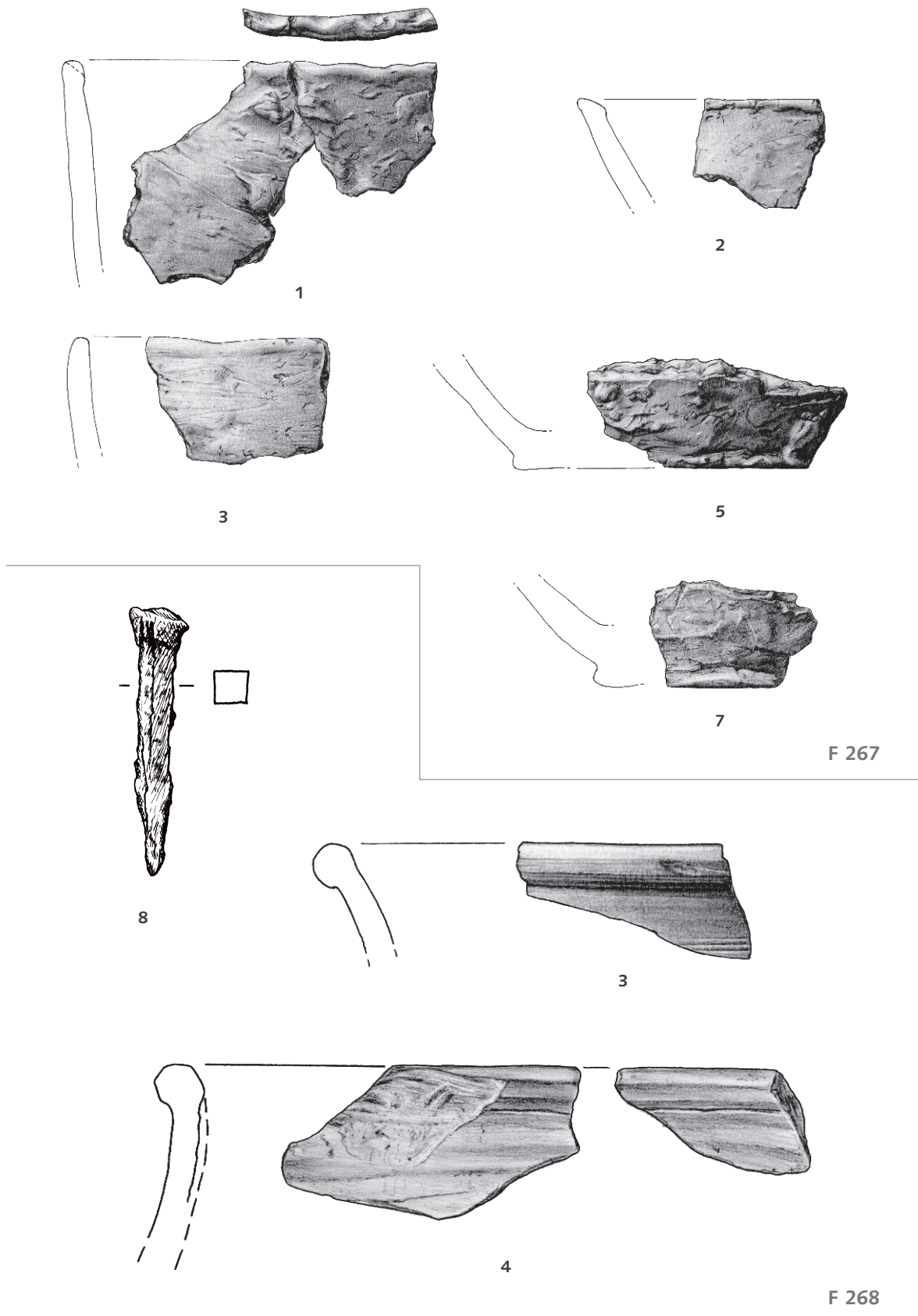

Beelen. Brandgrab (?) F 267. 1–3, 5, 7: Keramik. – Maßstab 1:2. Brandgrab F 268. 3, 4: Keramik. 8: Eisennagel. – Maßstab 1:1.



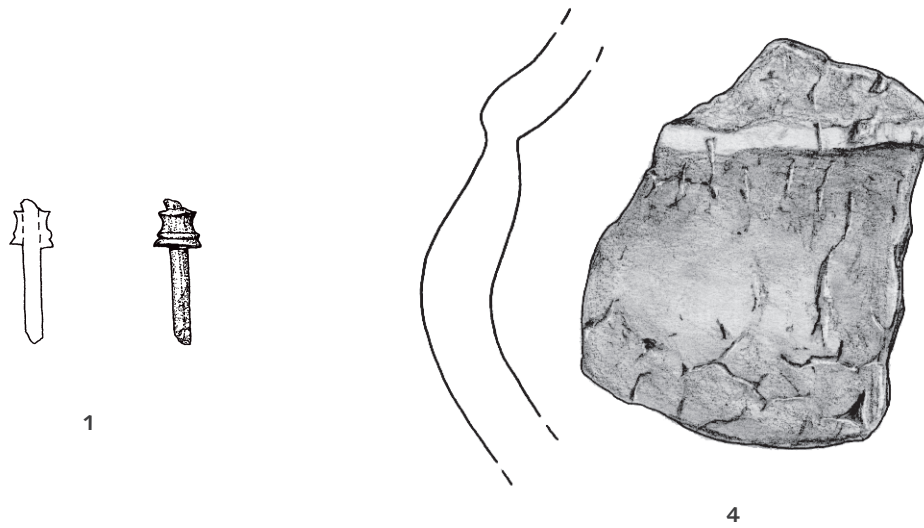

F 269

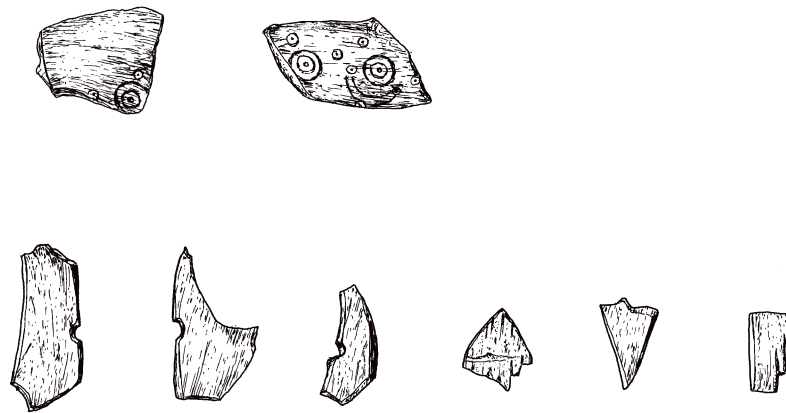

2

F 274

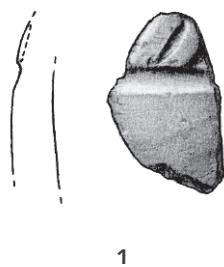

1

F 305

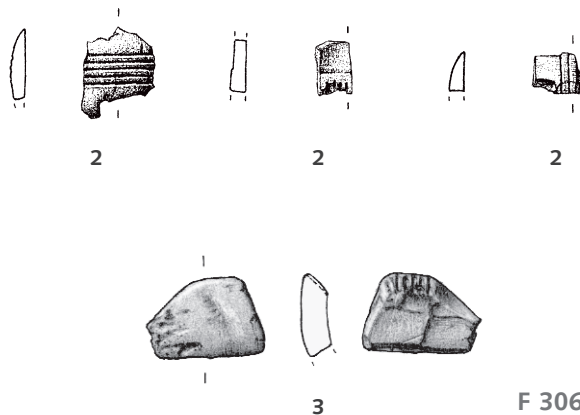

2

2

2

3

F 306

Beelen. Brandgrab F 269. 1: Bronzenadelfragment. 4: Keramik. – Brandgrab F 274. 2: Beinkammfragmente. – Brandgrab F 305. 1: Keramik. – Brandgrab F 306. 2: Beinkammfragmente. 3: Keramik (?). – Alles Maßstab 1:1.

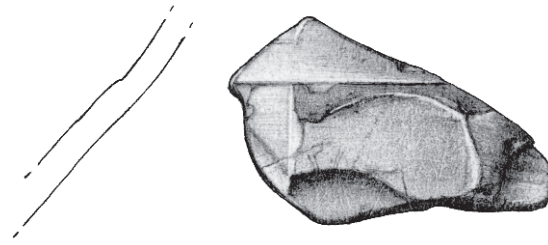

1

F 307

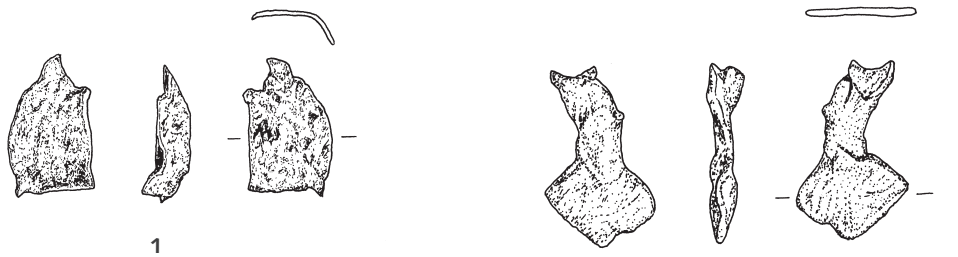

1

1



1

1

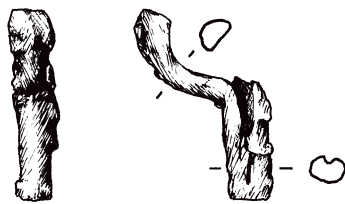

2



3

F 308

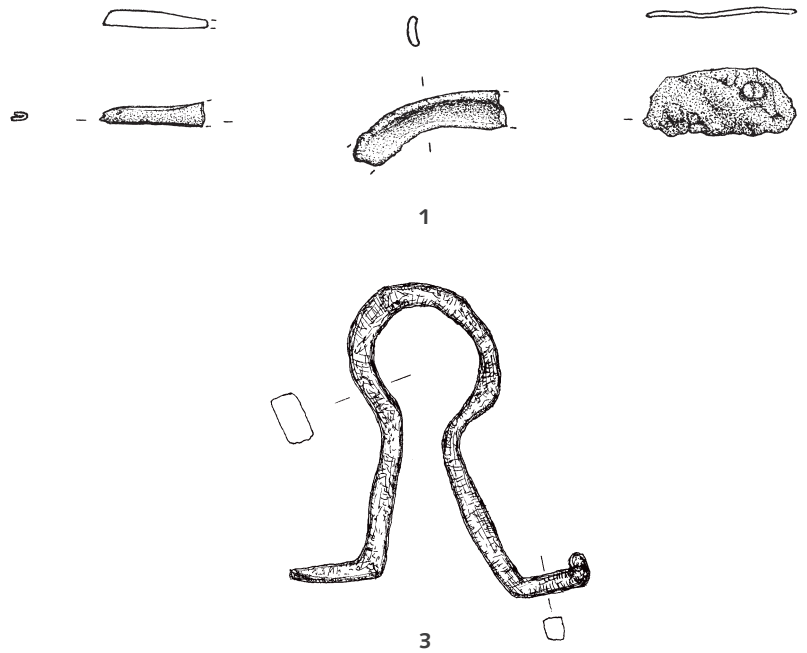

F 310

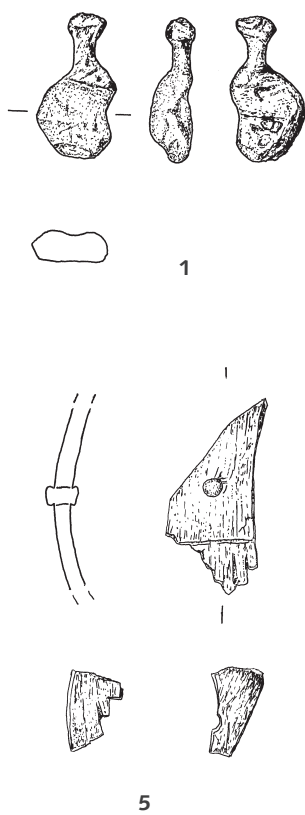

F 311

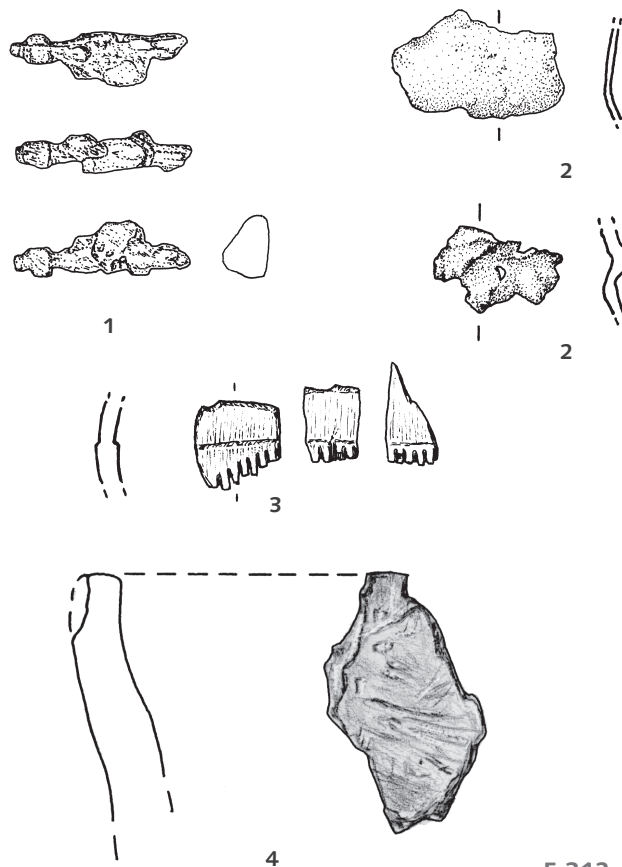

F 312

Beelen. Brandgrab F 310. 1: Bronzefragmente (u. a. Schnalle?). 3: Eisenkrampen. – Brandgrab F 311. 1: Bronzeschmelz (Niet?). 5: Beinkammfragmente. – Brandgrab F 312. 1: Eiserne Achse einer Bronzefibel. 2: Bronzeschmelz. 3: Beinkammfragmente. 4: Keramik. – Alles Maßstab 1:1.

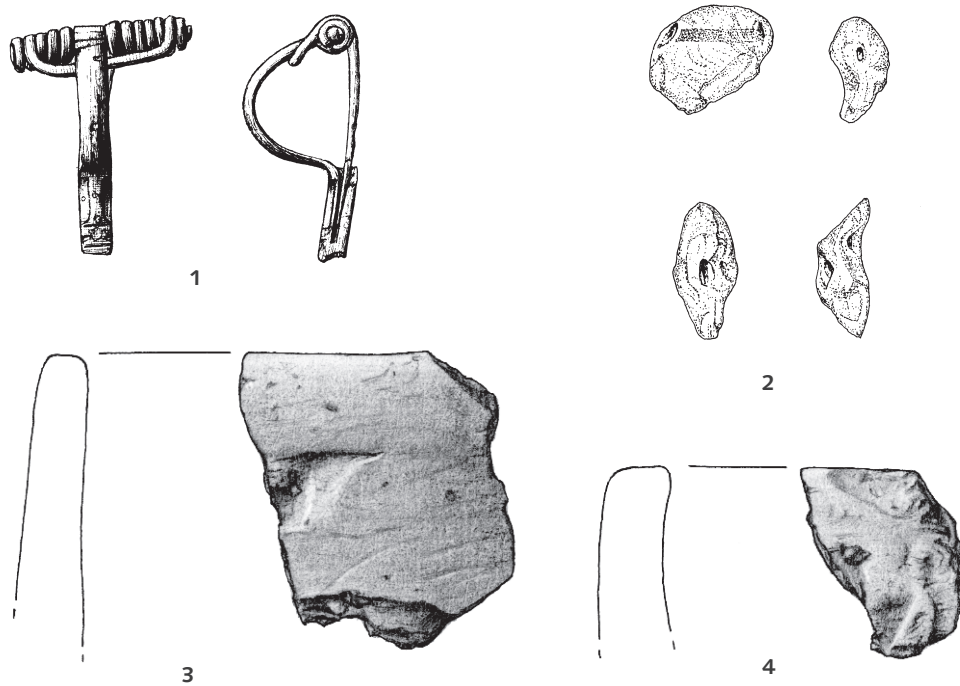

F 313



1

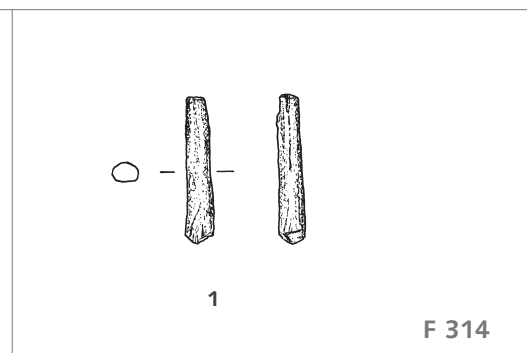

1

F 314

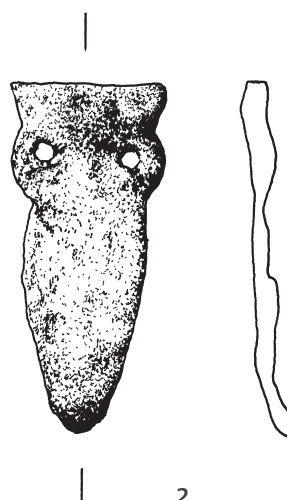

2

F 316

Beelen. Brandgrab F 313. 1: Bronzefibel. 2: Verschmolzene Glasperlen. 3, 4: Keramik. Brandgrab F 314. 1: Bronzestab (Dorn?). – Alles Maßstab 1:1. Körpergrab F 316. 1: Lanzenspitze. 2: Eiserner Beschlag. – 1: Maßstab 1:2. 2: Maßstab 1:1.

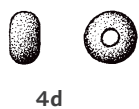
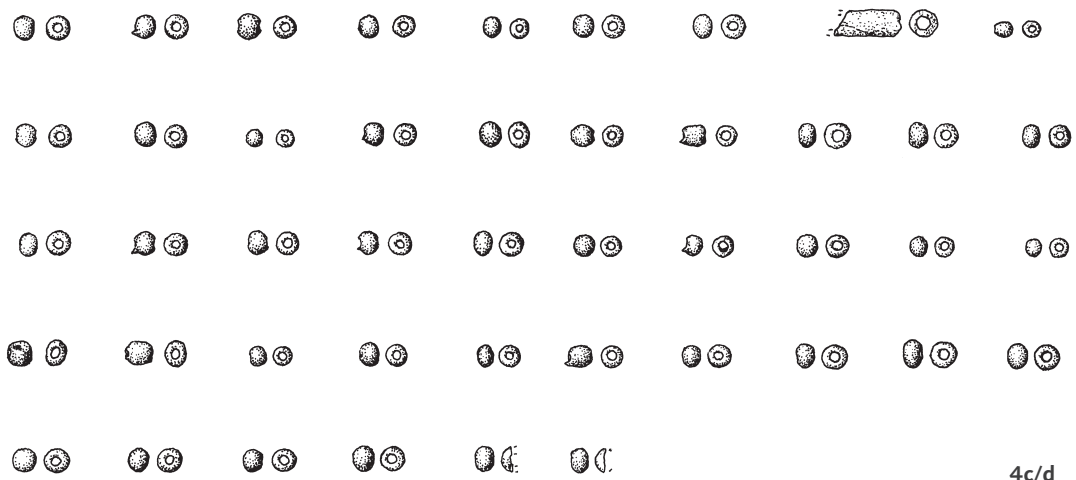
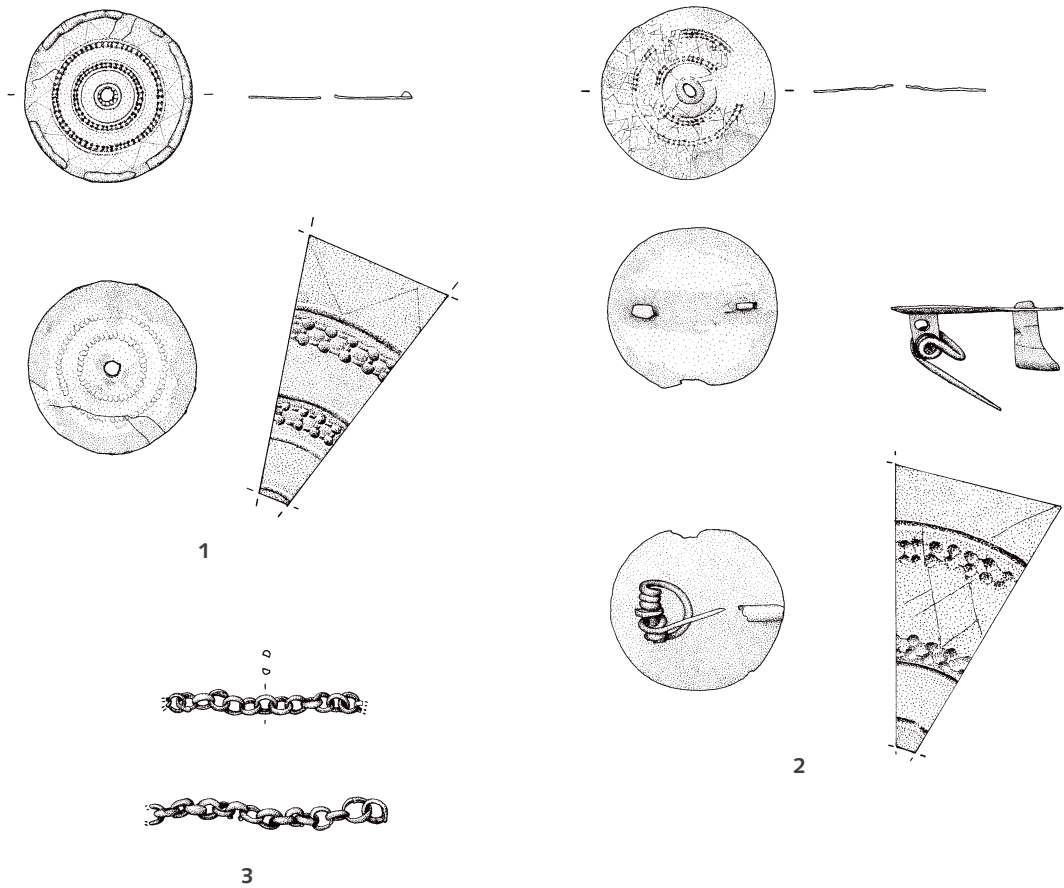

4c/d

4d

F 318

Beelen. Körpergrab F 318. 1: Bronzenes Zierblech einer Schalenfibel. 2: Bronzene Schalenfibel (Zierblech und Grundplatte). 3: Bronzекette. 4: Glasperlen. – 1–3: Maßstab 1:2. Ausschnitte Zierbleche: Maßstab 2:1. 4: Maßstab 1:1.

Tafel 38

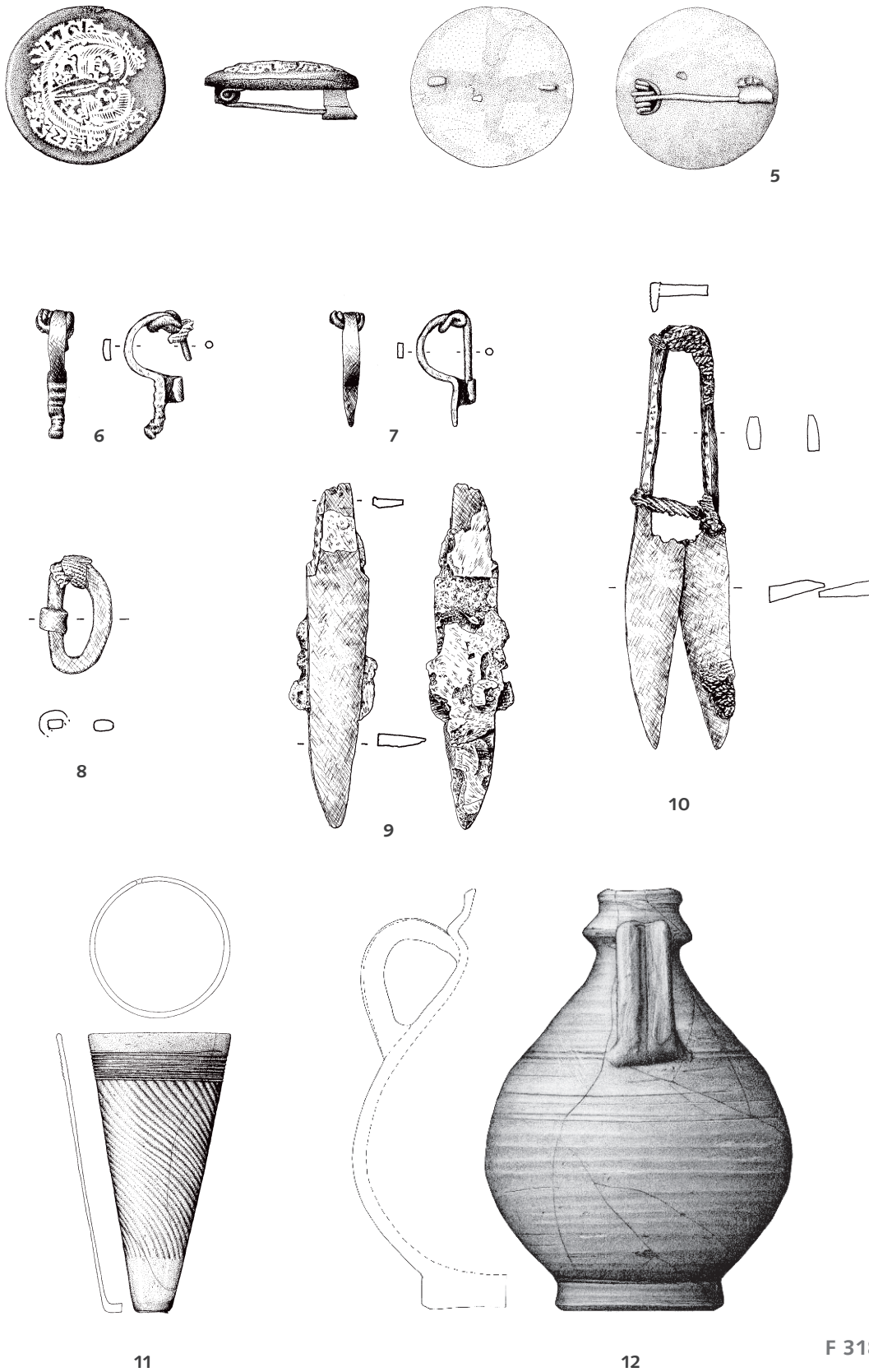

Beelen. Körpergrab F 318. 5: Bronzene Scheibenfibel mit Goldpressblechbelag. 6, 7: Eiserne Armbrustfibeln. 8: Eisenschnalle. 9: Eisenmesser. 10: Eiserne Schere. 11: Glasgefäß. 12: Keramikgefäß. – 5–10: Maßstab 1:2. 11, 12: Maßstab 1:3.



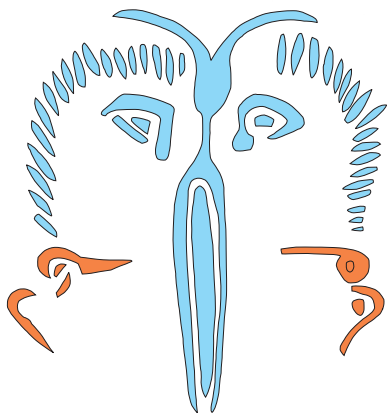

F 318

Beelen. Körpergrab F 318. 5: Scheibenfibel mit Goldpressblechbeleg. Mitte: Umzeichnung des zentralen Motivs. Unten links: Hervorhebung der Frontalmaske (blau) und der beiden bogenförmigen Ornamente (orange). Unten rechts: Hervorhebung der Profilköpfe (lila und grün) – Alles o. Maßstab. Foto aus: GRÜNEWALD 1999c, 206.





2

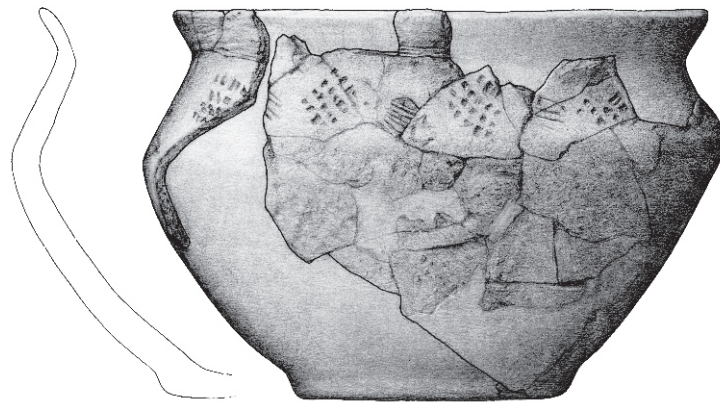

3

F 319

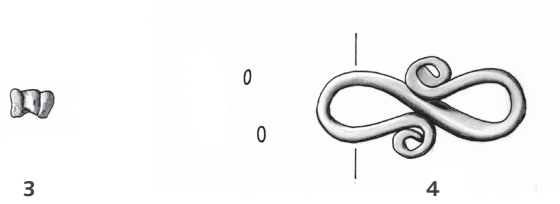

F 1

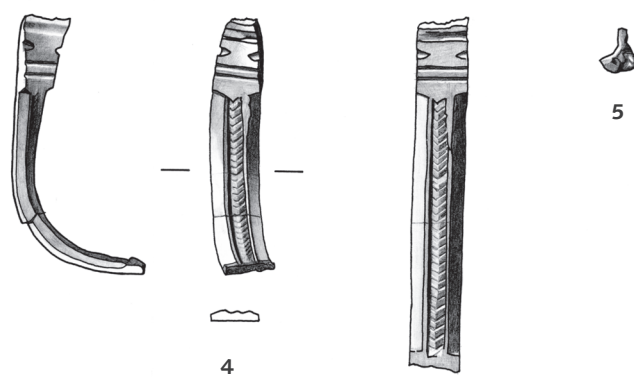
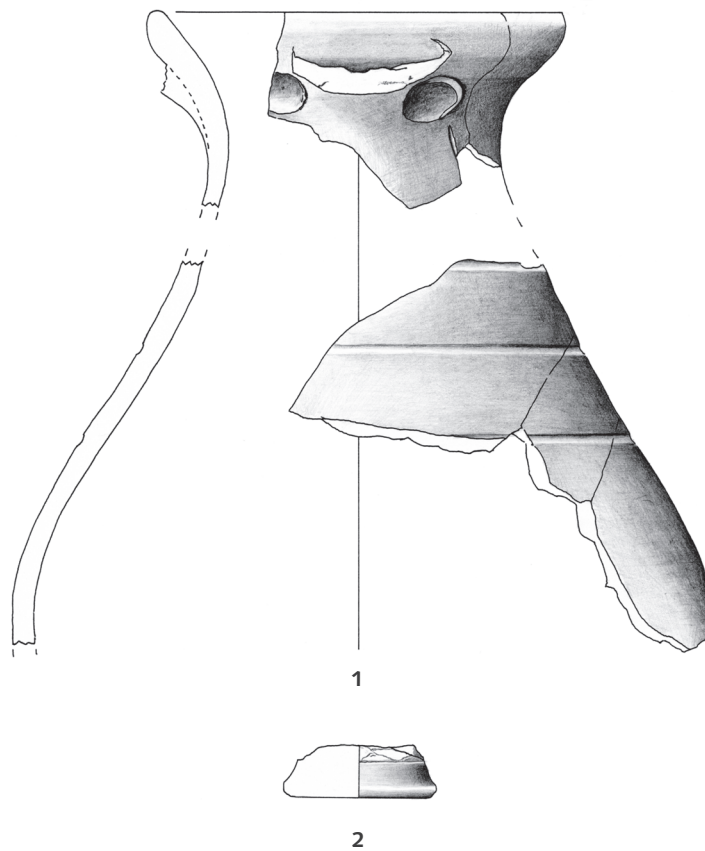

F 4

Herzebrock-Clarholz. Brandgrab F 1. 3: Glasperle. 4: Bronze-Kettenverschluss. – Maßstab 1:1. Brandgrab F 4. 1: Teile eines Keramikkruges. 2: Keramik-Gefäßfuß. 4: Bronzebeschlag. 5: Bronzeniet. – 1, 2: Maßstab 1:2. 4, 5: Maßstab 1:1.

Tafel 42

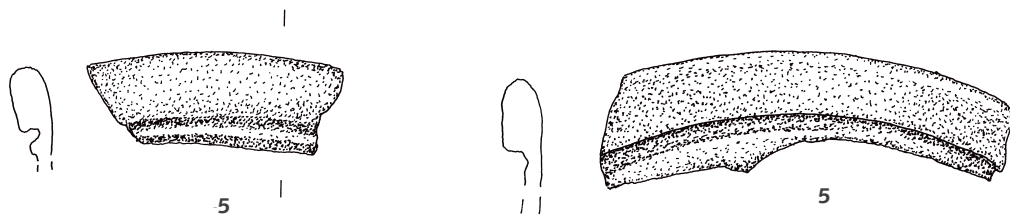
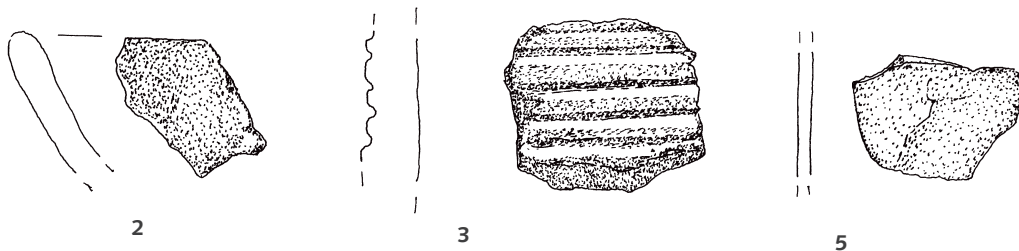
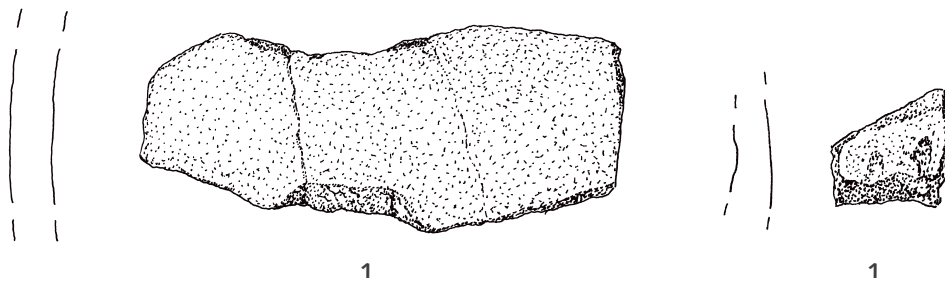
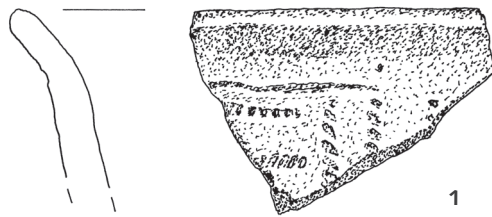
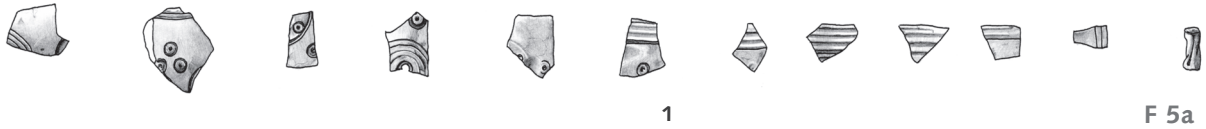

Herzebrock-Clarholz. Brandgrab F 5a. 1: Beinkammfragmente mit Bronzeniet. Brandgrab F 6. 1-3: Keramikscherben. 5: Glasbecherscherben. 6: Beinkammfragment. – Alles Maßstab 1:1.

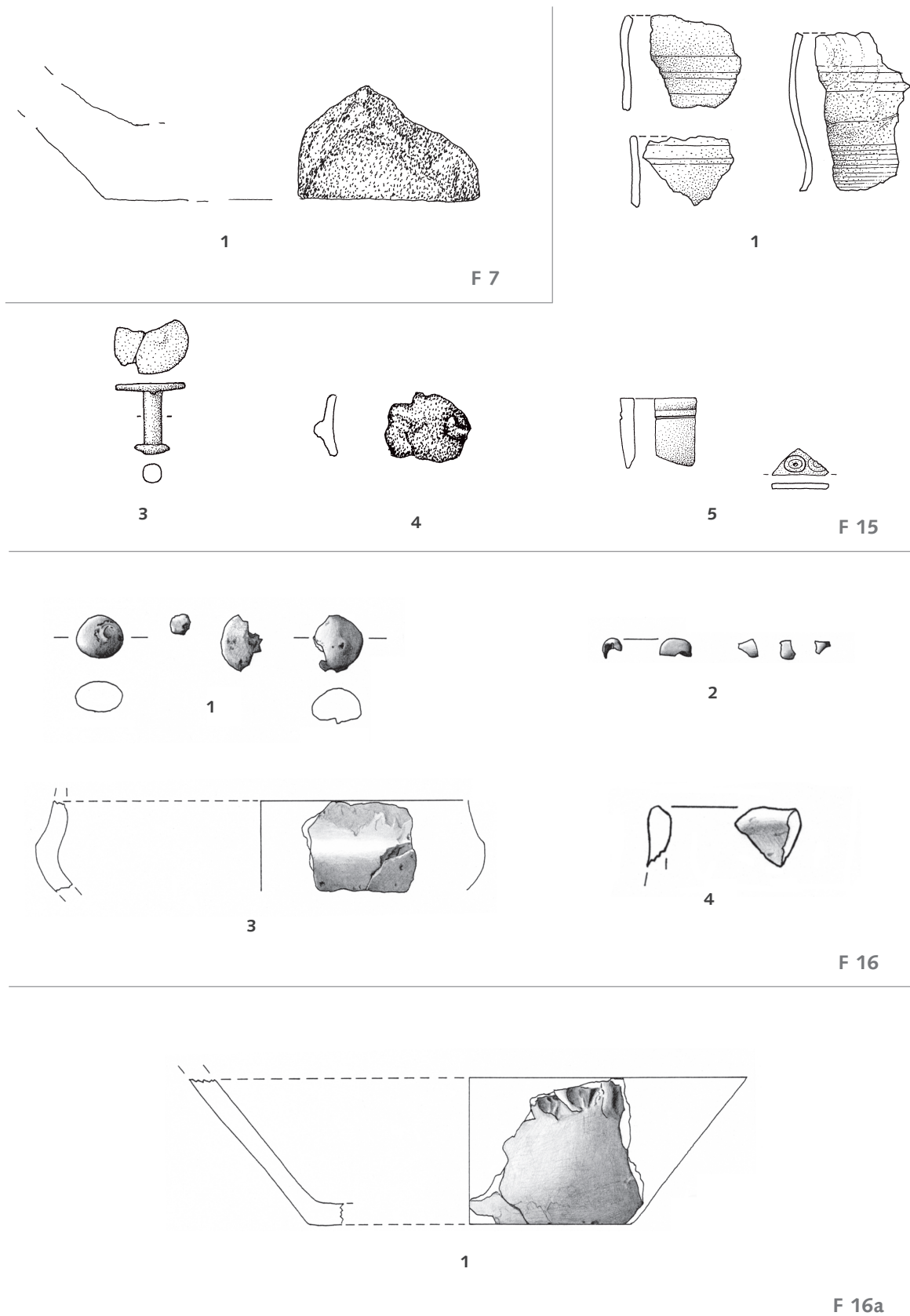

Herzebrock-Clarholz. Brandgrab F 7. 1: Keramik. – Maßstab 1:1. Brandgrab F 15. 1: Bronzeblech. 3: Bronzeniet. 4: Bronzeblech mit Niet. 5: Beinkammfragmente. – Maßstab 1:1. Brandgrab F 16. 1, 2: Glasperlen. 3, 4: Keramik. – 1, 2, 4: Maßstab 1:1. 3: Maßstab 1:2. Brandgrab F 16a. 1: Keramik. – Maßstab 1:2.

Tafel 44

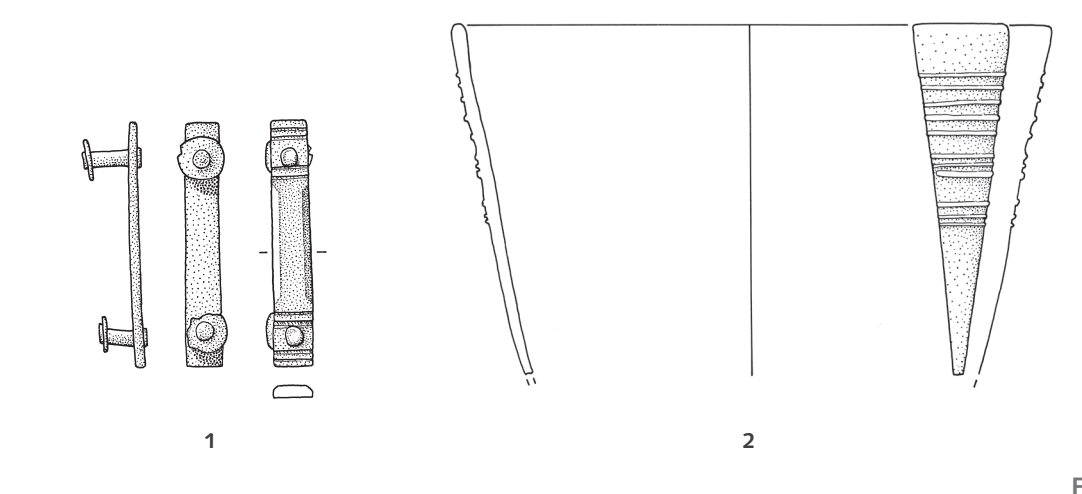
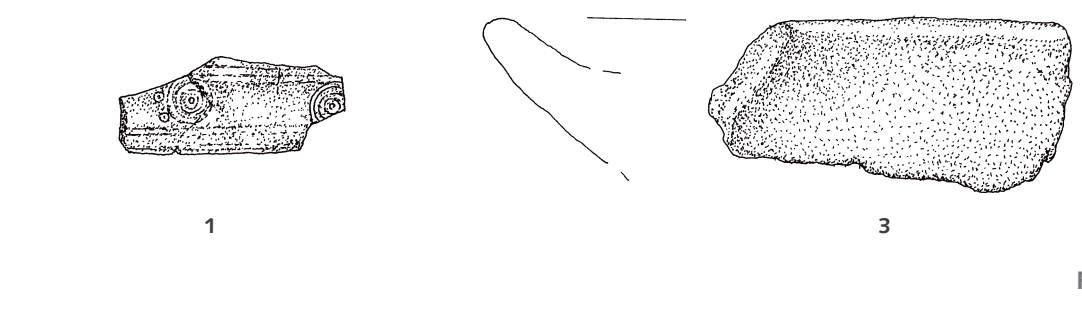
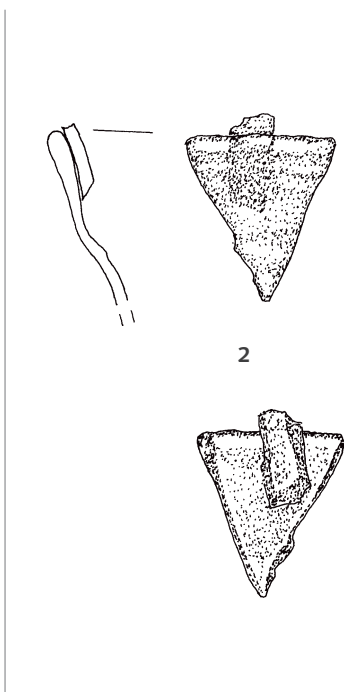
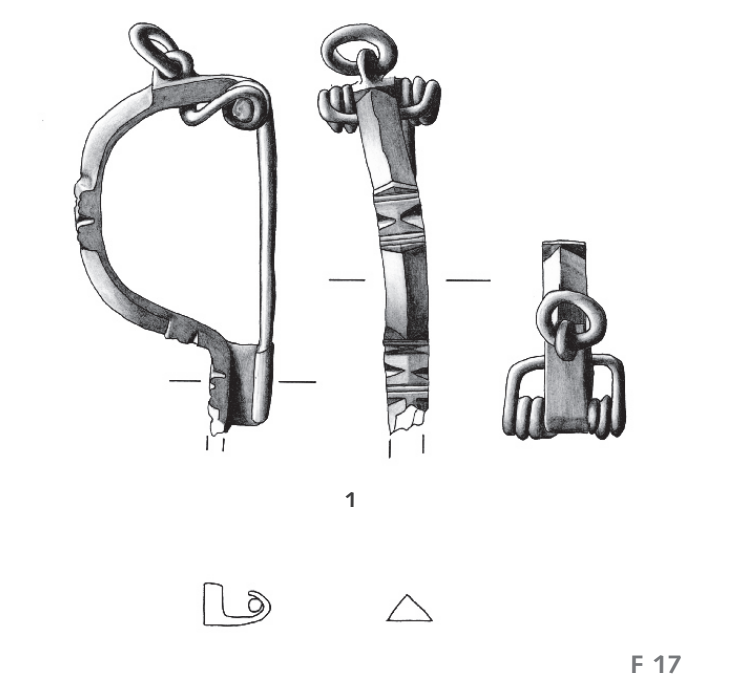

Herzebrock-Clarholz. Brandgrab F 17. 1: Eiserne Fibel. Brandgrab F 19. 1: Kammetui. 2: Glasbecherscherbe. 3: Keramik. Brandgrab F 20. 1: Bronzebeschlag. 2: Glasbecherscherbe. – Alles Maßstab 1:1.

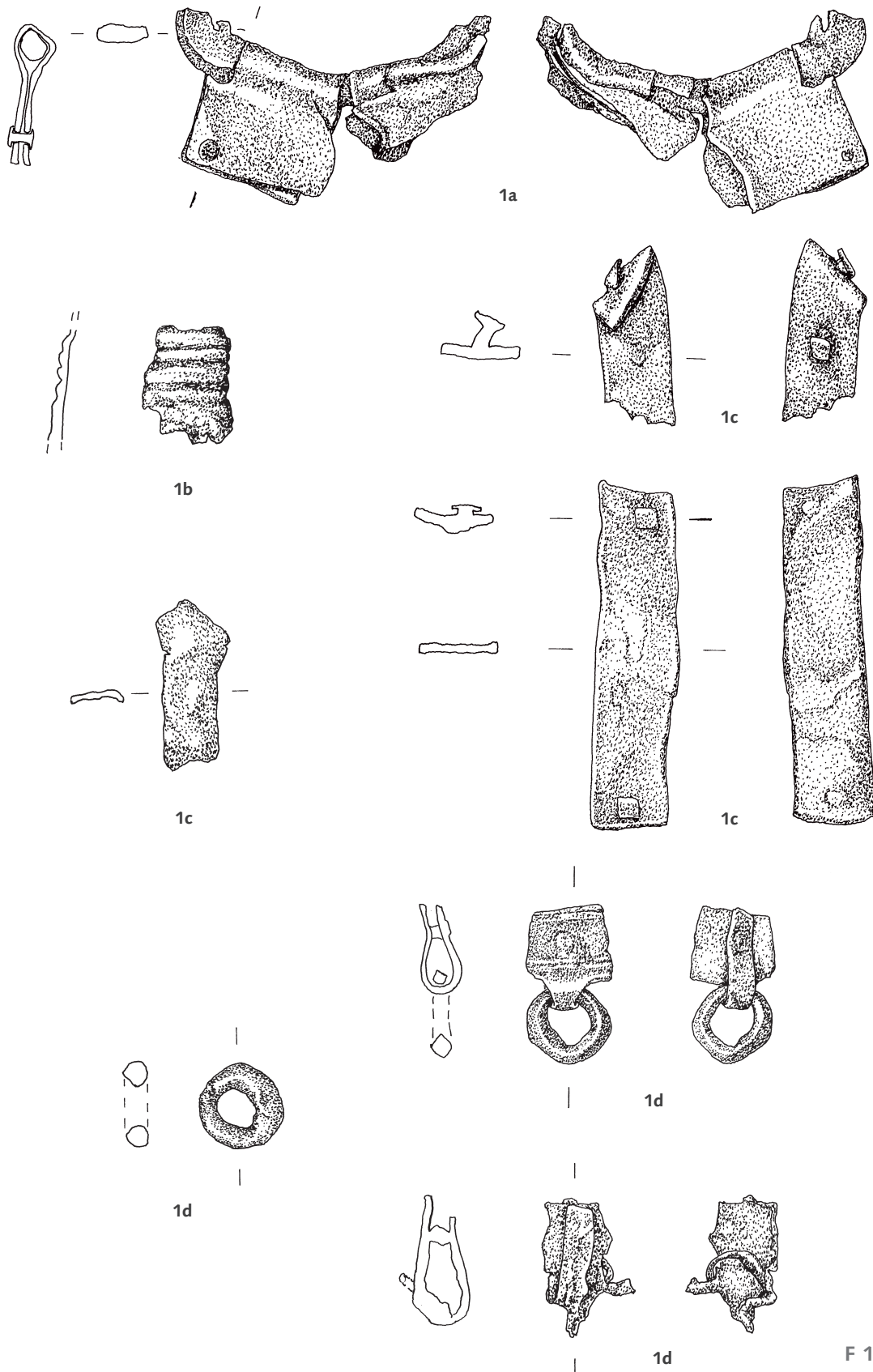

Herzebrock-Clarholz. Brandgrab F 18. 1: Bronzene Gürtelgarnitur. a: Schnalle. b: Astragalröhrchen. c: Leisten. d: Gürtelösen. – Alles Maßstab 1:1.

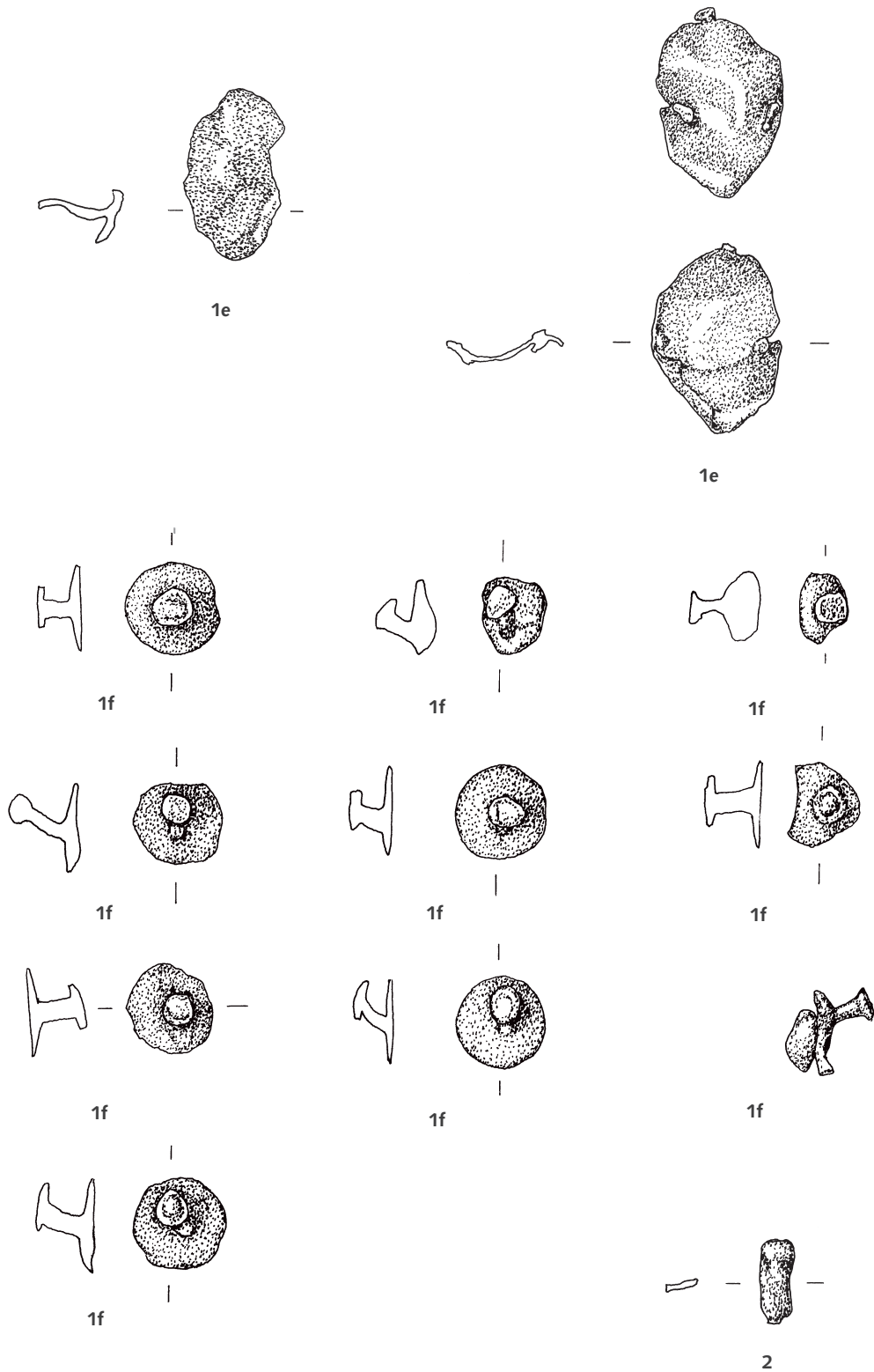

F 18



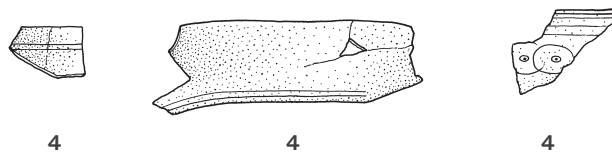
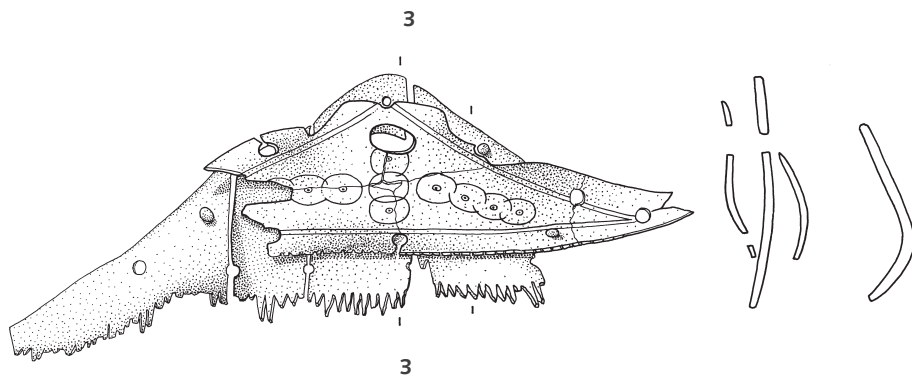

F 18

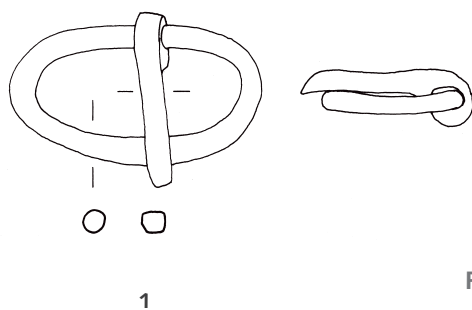

Herzebrock-Clarholz. Brandgrab F 18. 3: Beinkamm. 4: Kammetui. Brandgrab F 23. 1: Eisenschnalle. Brandgrab F 24. 1: Bronzeniet. – Alles Maßstab 1:1. Foto o. Maßstab.

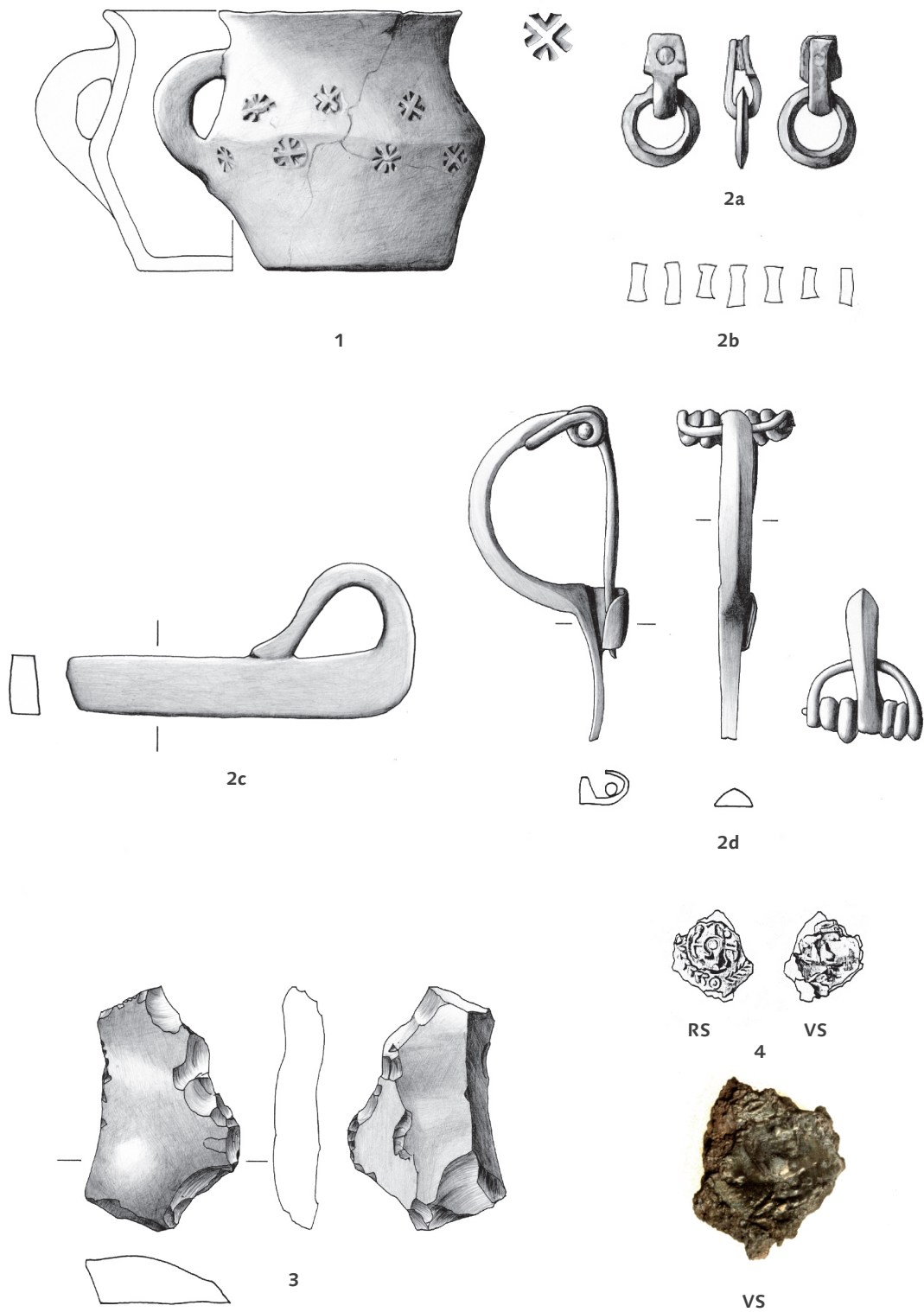

F 26

Herzebrock-Clarholz. Körpergrab F 26. 1: Keramikgefäß. 2: Reste einer Gürteltasche mit Inhalt. 2a: Bronzene Gürtelöse. 2b: Bronzeniete. 2c: Feuerstahl. 2d: Eisenfibel. 3: Feuerstein. 4: Silbermünze (VS = Vorderseite, RS = Rückseite) – 1: Maßstab 1:2, Stempel: Maßstab 1:1. 2a–d, 3, 4: Maßstab 1:1. Foto o. Maßstab.

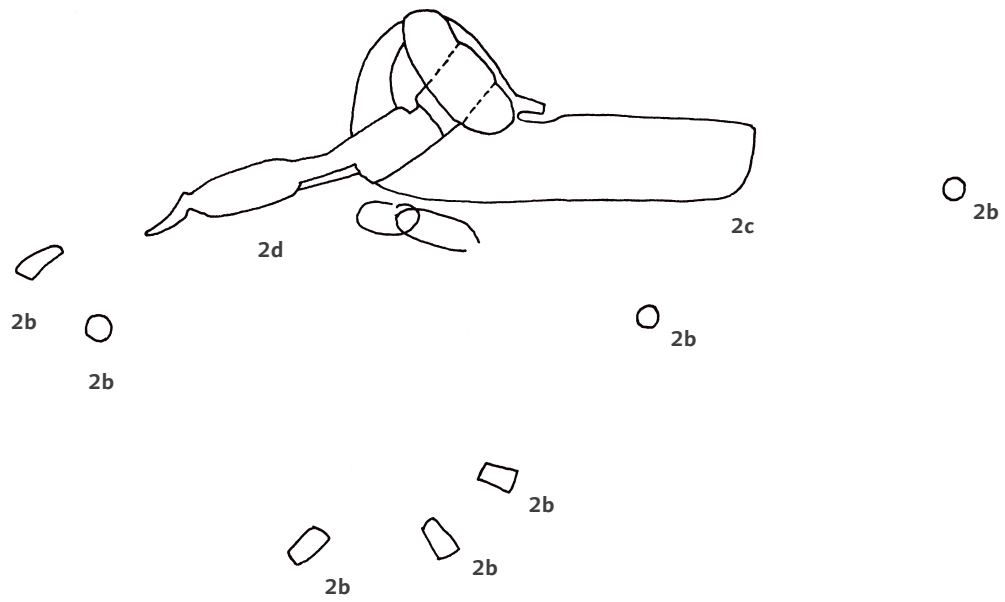

F 26

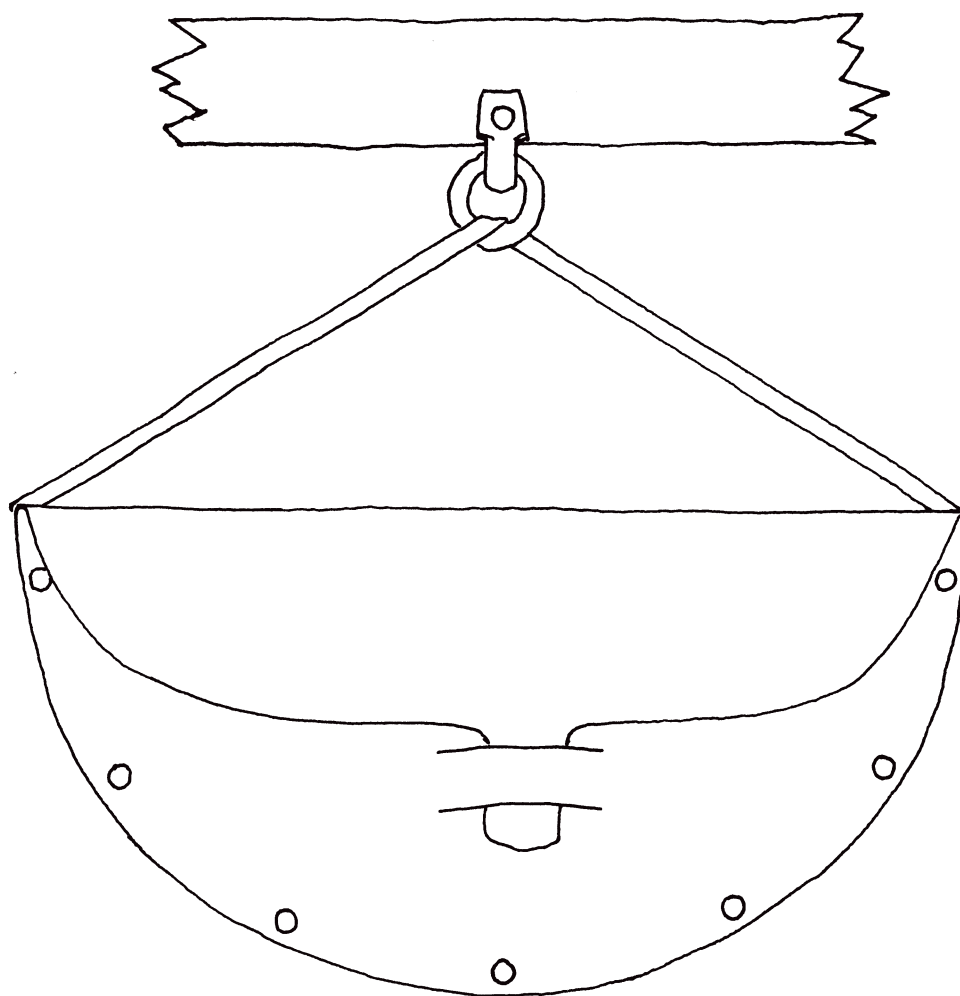

Herzebrock-Clarholz. Körpergrab F 26. Lage der Funde 2b–d und Rekonstruktion der Gürteltasche. Aus: BEST 1990/1991, 439 (Abb. 7). – Ohne Maßstab.

# Tafel 50

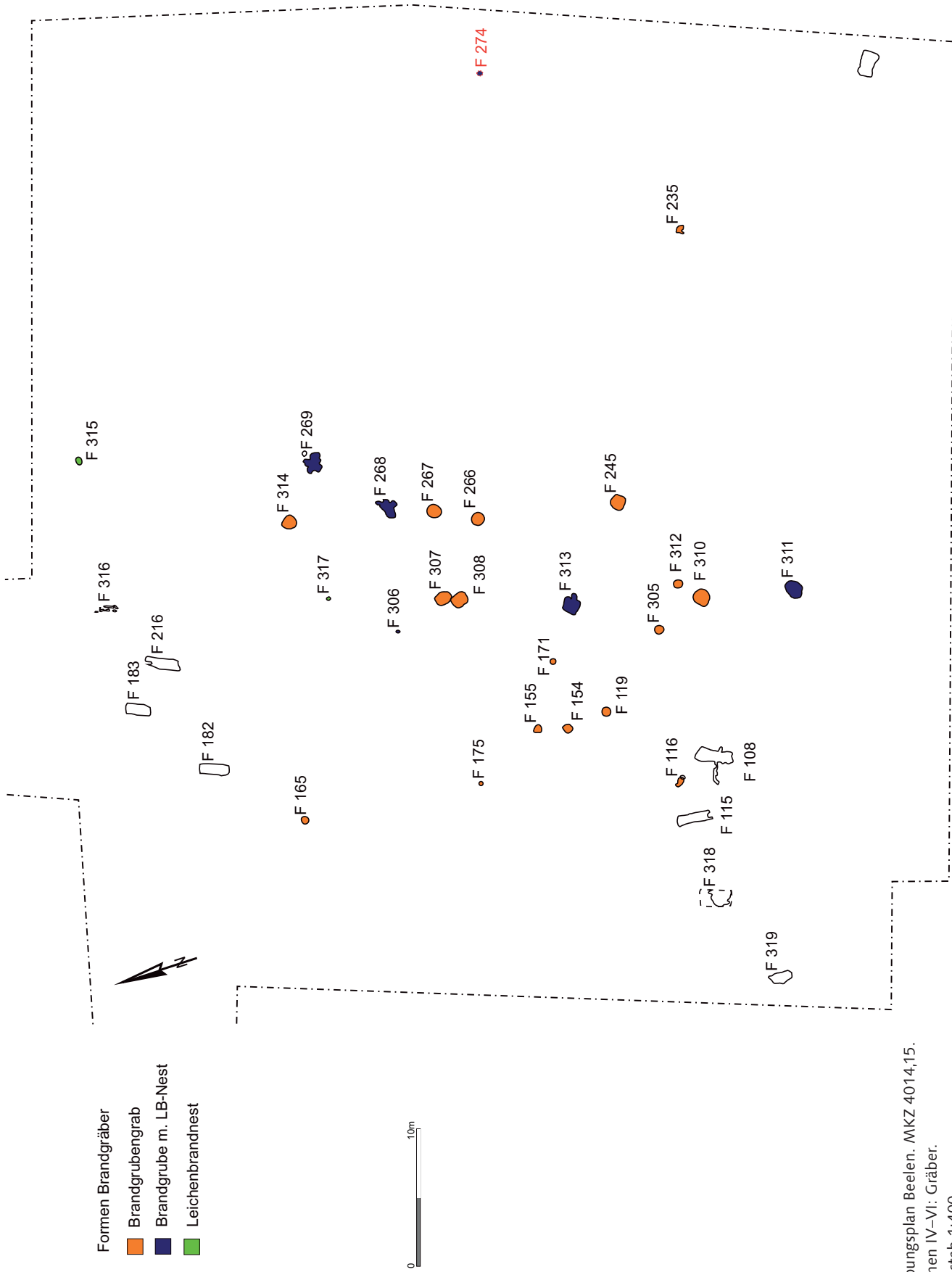

Grabungsplan Beelen. MKZ 4014,15.  
 Flächen IV-VI: Gräber.  
 Maßstab 1:400.

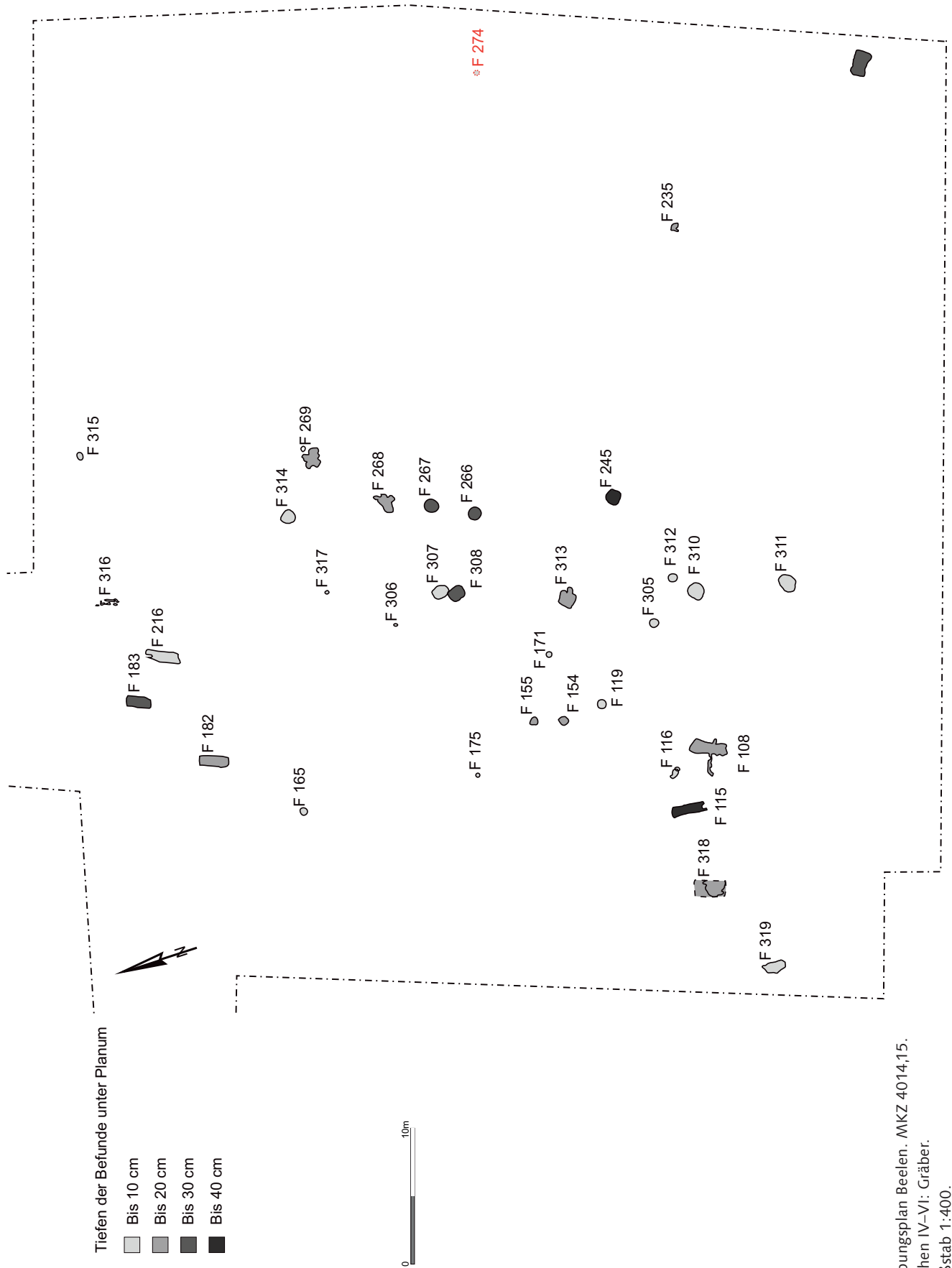

Grabungsplan Beelen. MKZ 4014,15.  
 Flächen IV-VI: Gräber.  
 Maßstab 1:400.

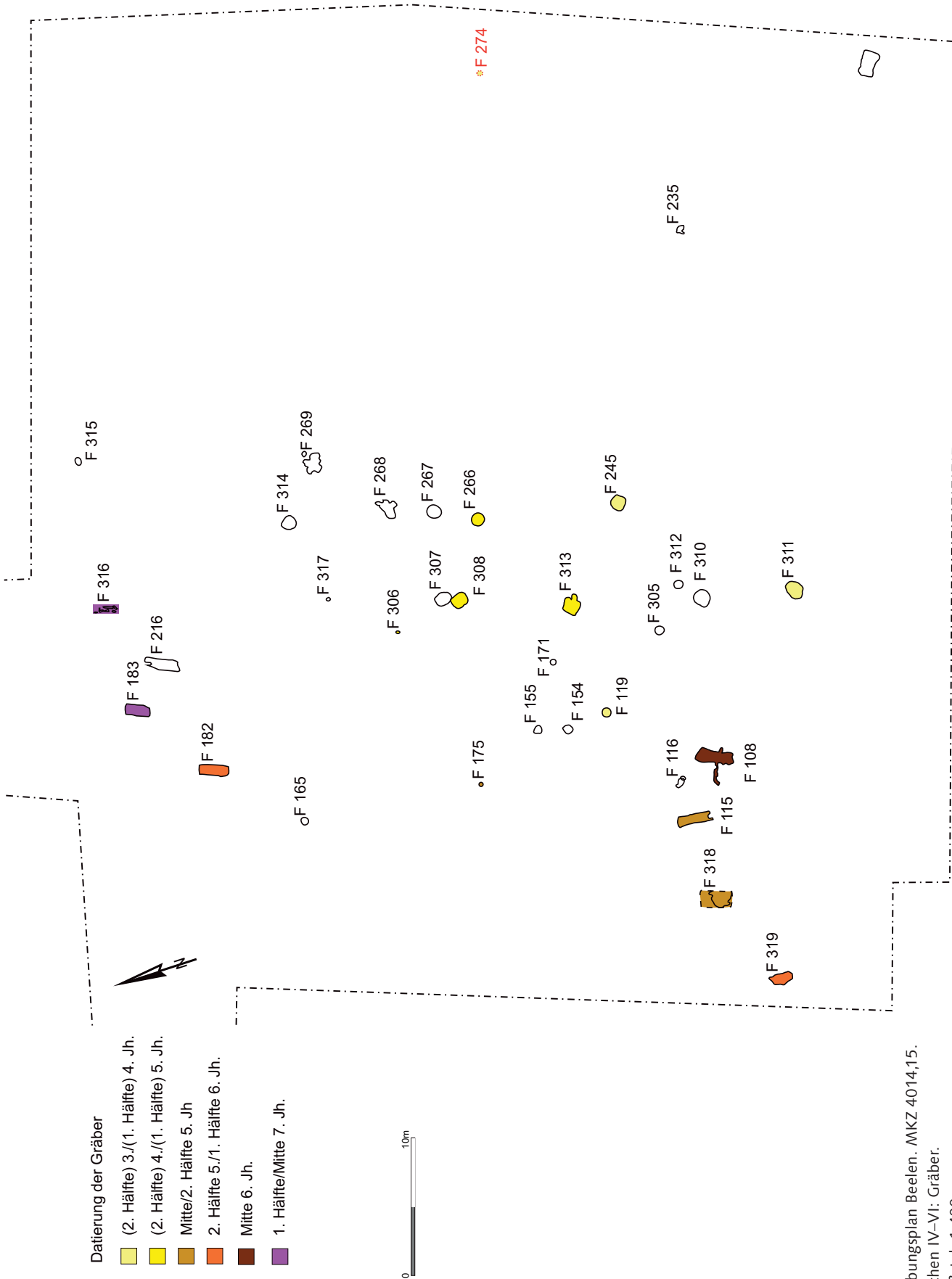

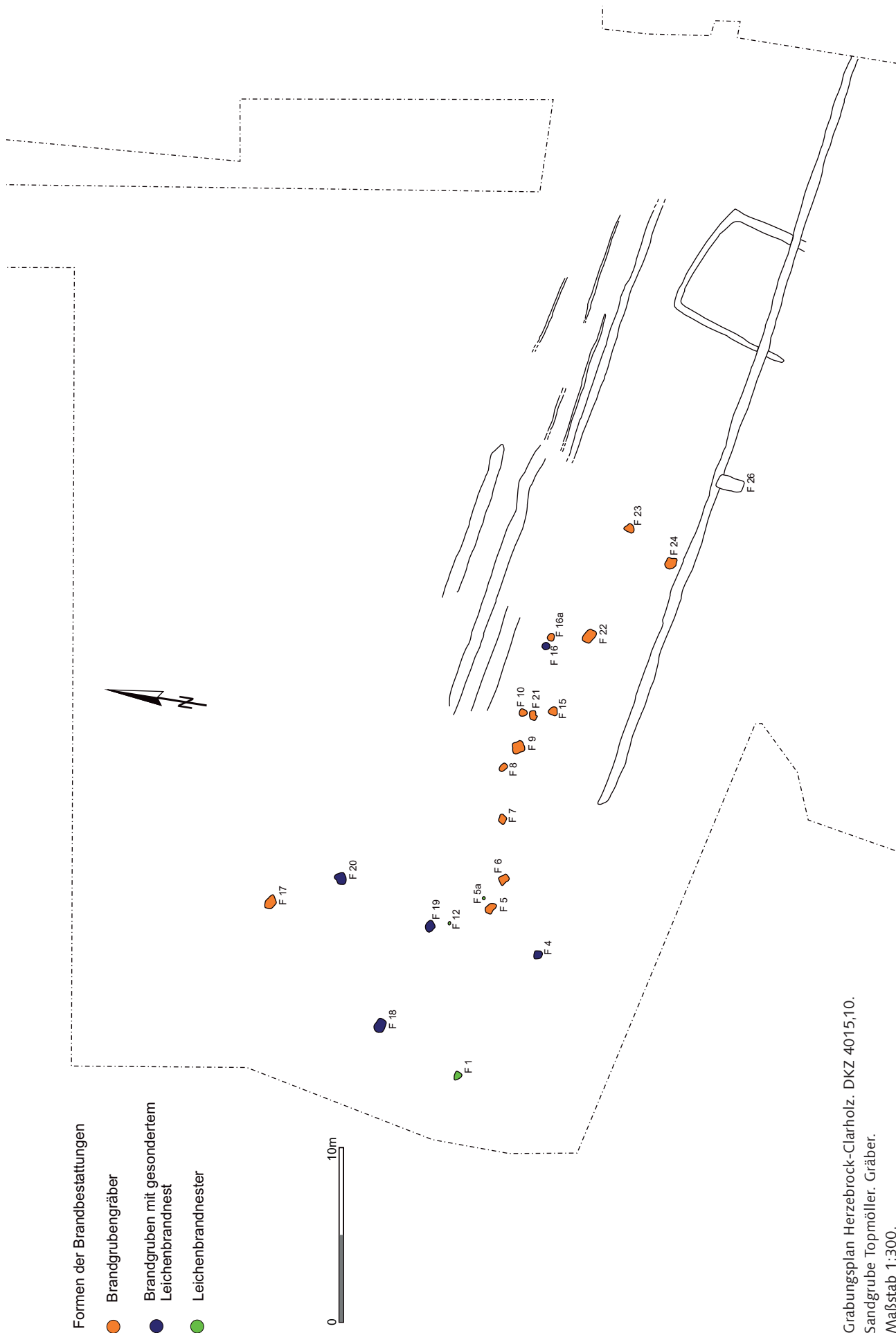

Grabungsplan Herzebrock-Clarholz. DKZ 4015,10.  
 Sandgrube Topmüller. Gräber.  
 Maßstab 1:300.



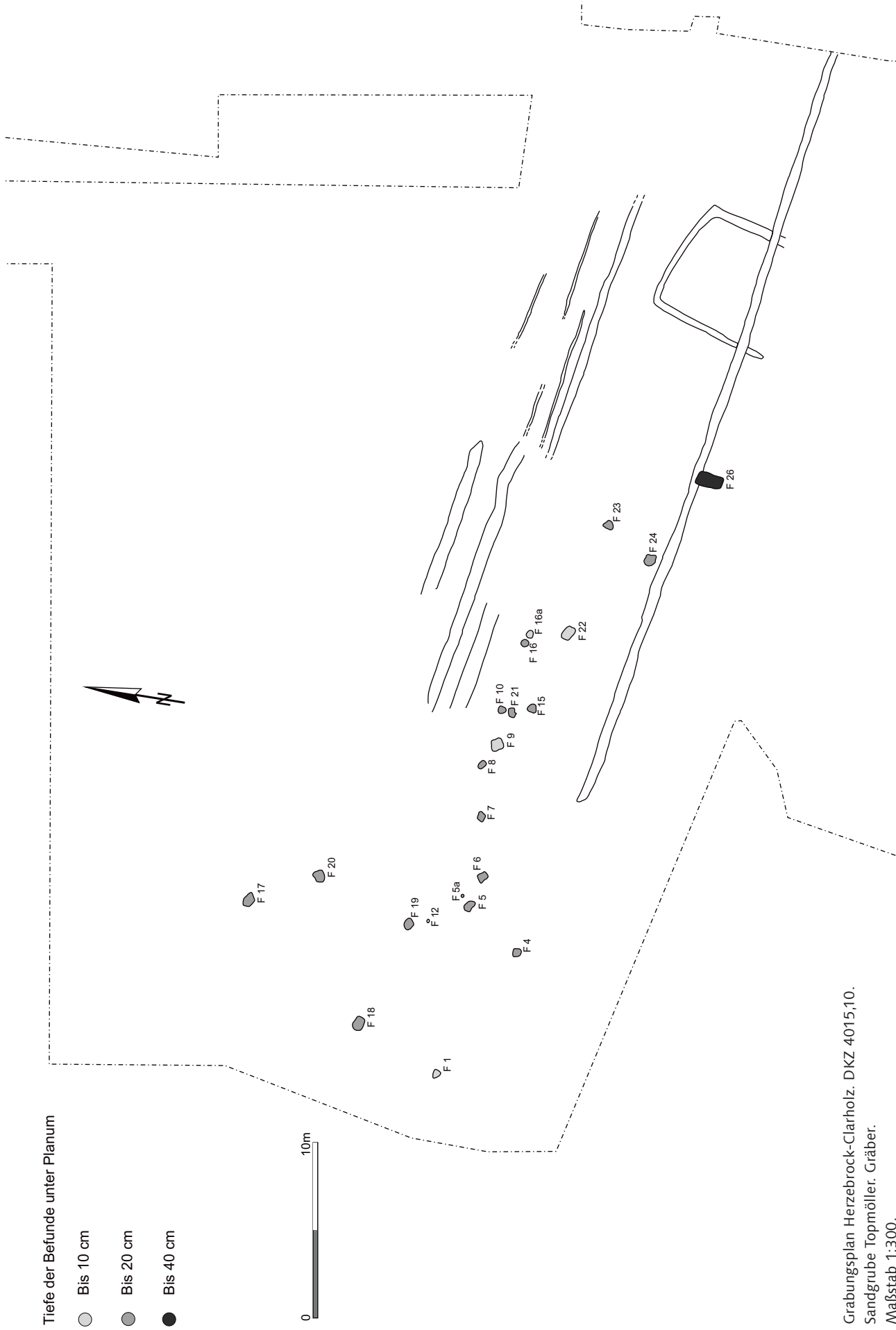

Grabungsplan Herzebrock-Clarholz. DKZ 4015,10.  
Sandgrube Topmöller. Gräber.  
Maßstab 1:300.

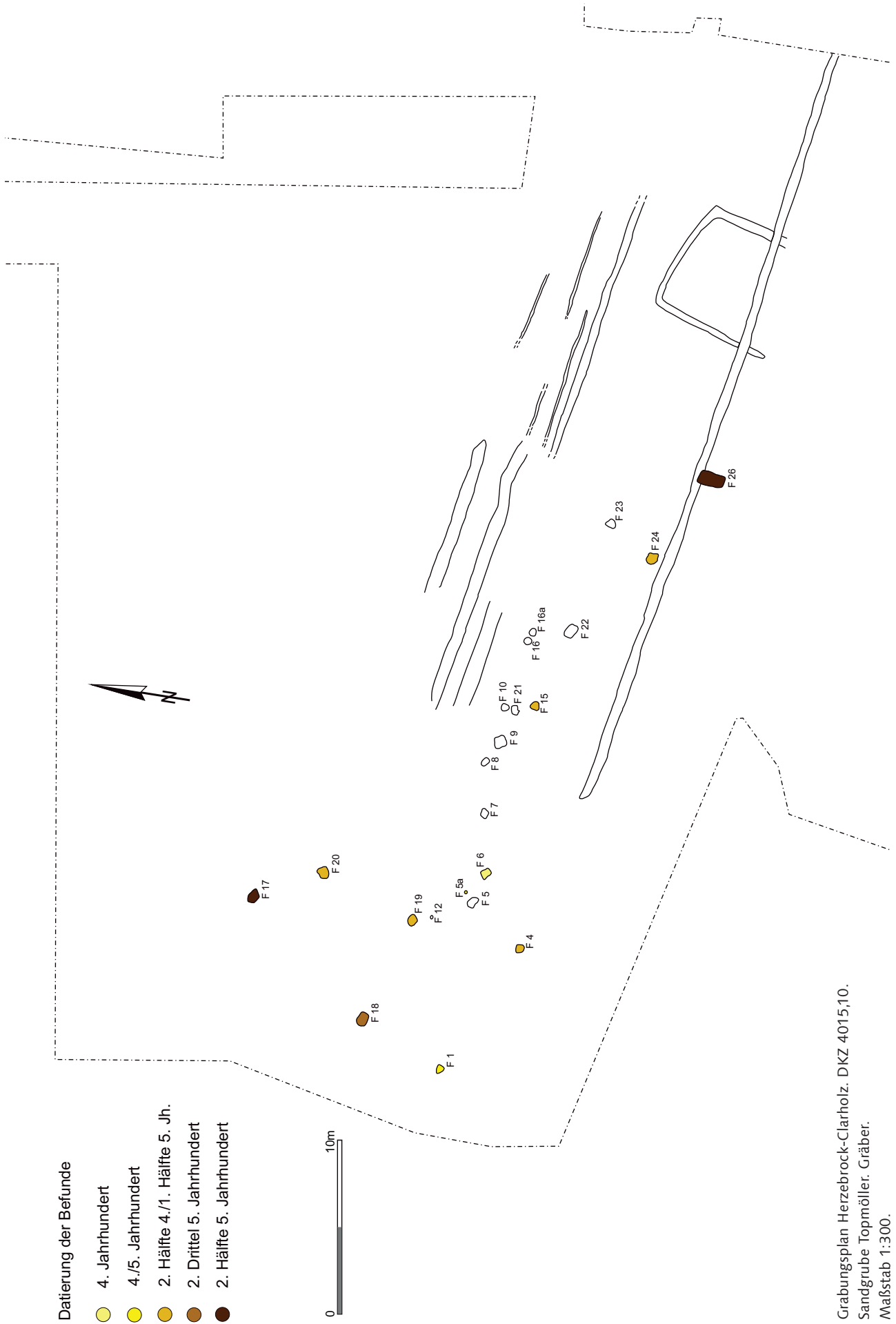



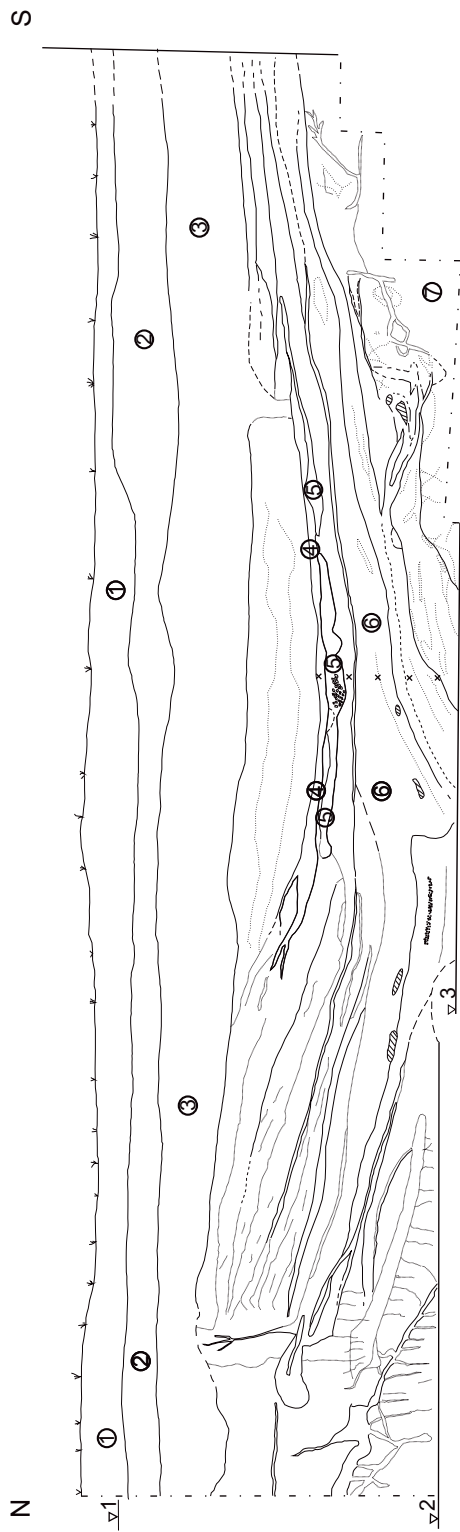

- x Pollenanalyseproben
- 1 62,43 m ü. NN
- 2/3 Aufgestautes Grundwasser
- 4 Wasserspiegel Baggersee
- ☞ Holz
- ☞ Leichenbrand
- ☞ Holzkohle

Herzebrock-Clarholz. Moorsenke (F 14). Umzeichnung Ostprofil, Suchschnitt 2. Maßstab 1:50.

- 1: Humus.
- 2: Eschauftag.
- 3: Graubrauner, leicht lehmiger Sand.
- 4: Dünne Moorschicht über Hauptfundschrift.
- 5: Hauptfundschrift.
- 6: Moorschichten.
- 7: Anstehender Sand.





Herzebrock-Clarholz. Moorsenke (F 14). Westprofil des Profilsteigs. Maßstab 1:50.

- 1: Lehmiger Sand.
  - 2: Hellbrauner bis grauer Sand.
  - 3: Dunkelbraune Moorschicht.
  - 4: Hauptfundschiebt.
  - 5: »Fettige« braune Moorschicht
  - 6: Schwarzes HK-führendes Band.
  - 7: Störungen.
  - 8: Anstehender Sand.
- Maßstab 1:50.



Tafel 60

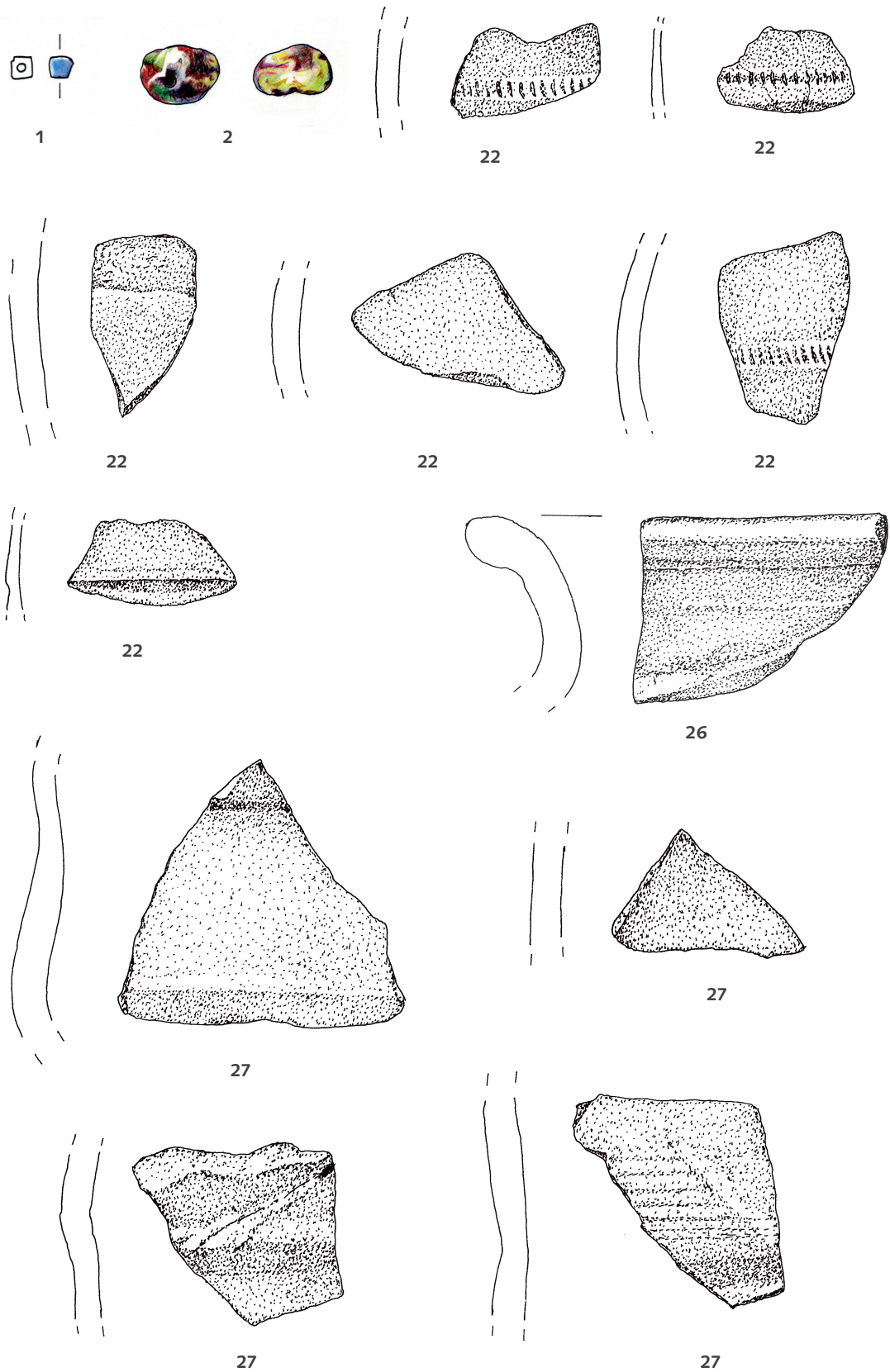

F 14, Suchschnitt 2



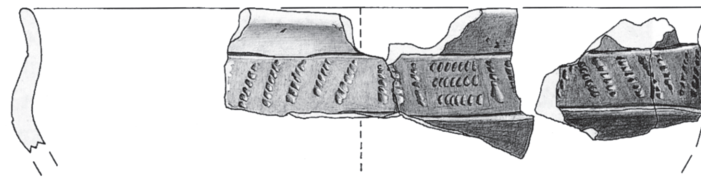

29

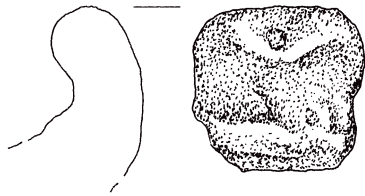

40

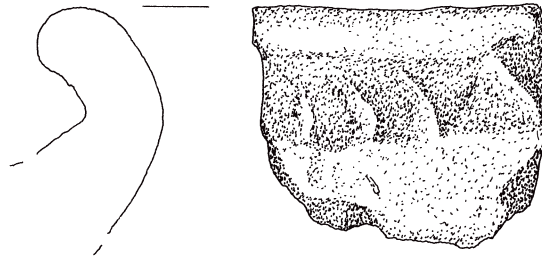

40

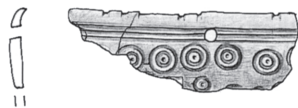

44

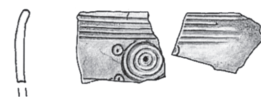

45

F 14, Suchschnitt 2

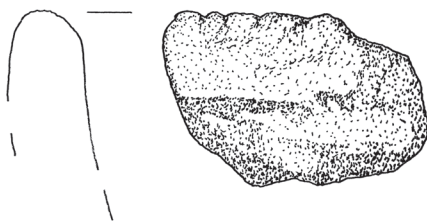

A/10 (1)

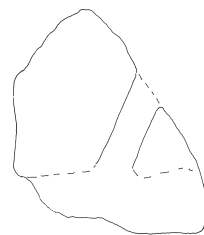

N/14 (1)

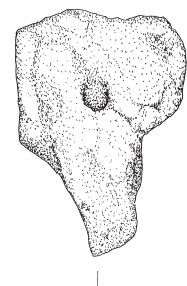

F 14, Planum 0

Herzebrock-Clarholz. Moorsenke (F 14). Suchschnitt 2. 29, 40: Keramik. 44: Beinkammfragment. 45: Kammetui. – 29: Maßstab 1:2. 40, 44, 45: Maßstab 1:1. Planum 0. A/10 (1): Keramik. – Maßstab 1:1. N/14 (1): Webgewichtfragment. – Maßstab 1:2.

Tafel 62

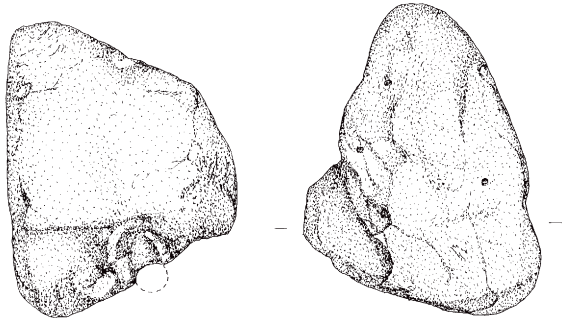

E/11 (1)

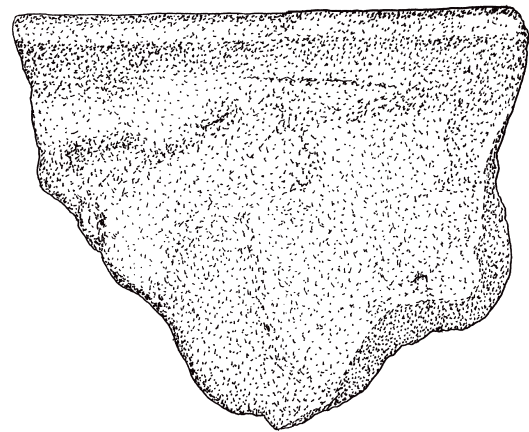
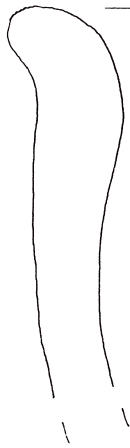
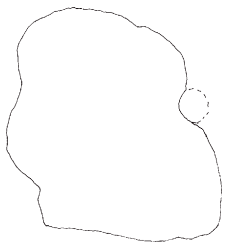

H/18 (1)

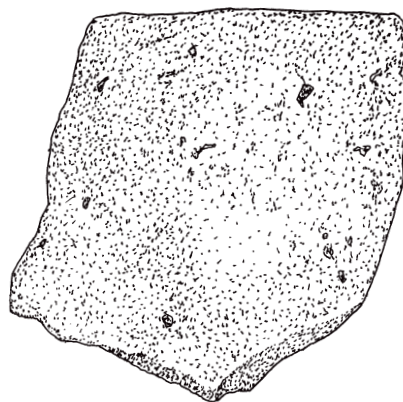

M/13 (1)

F 14, Planum 1

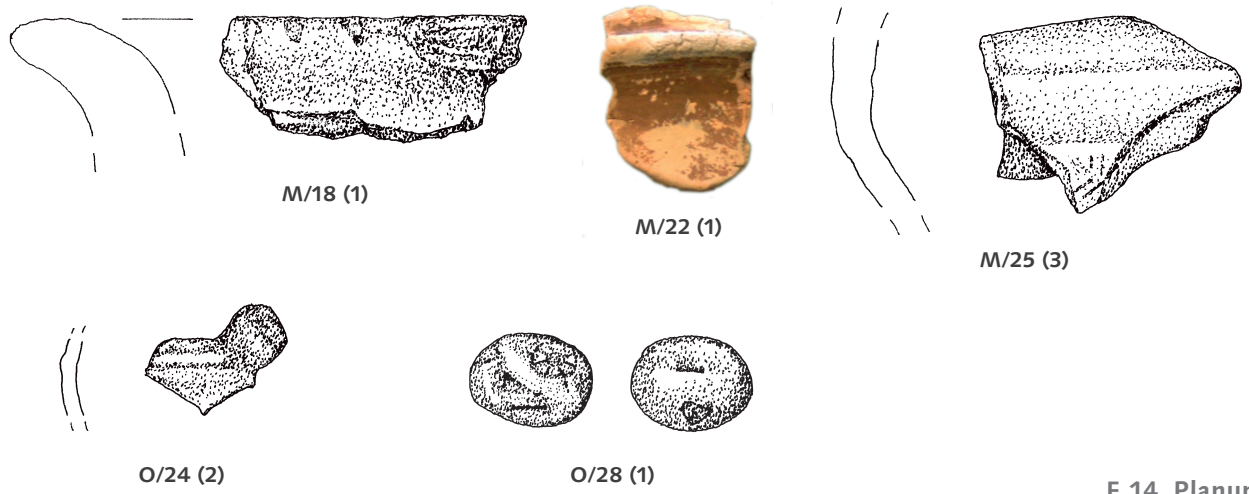

F 14, Planum 2

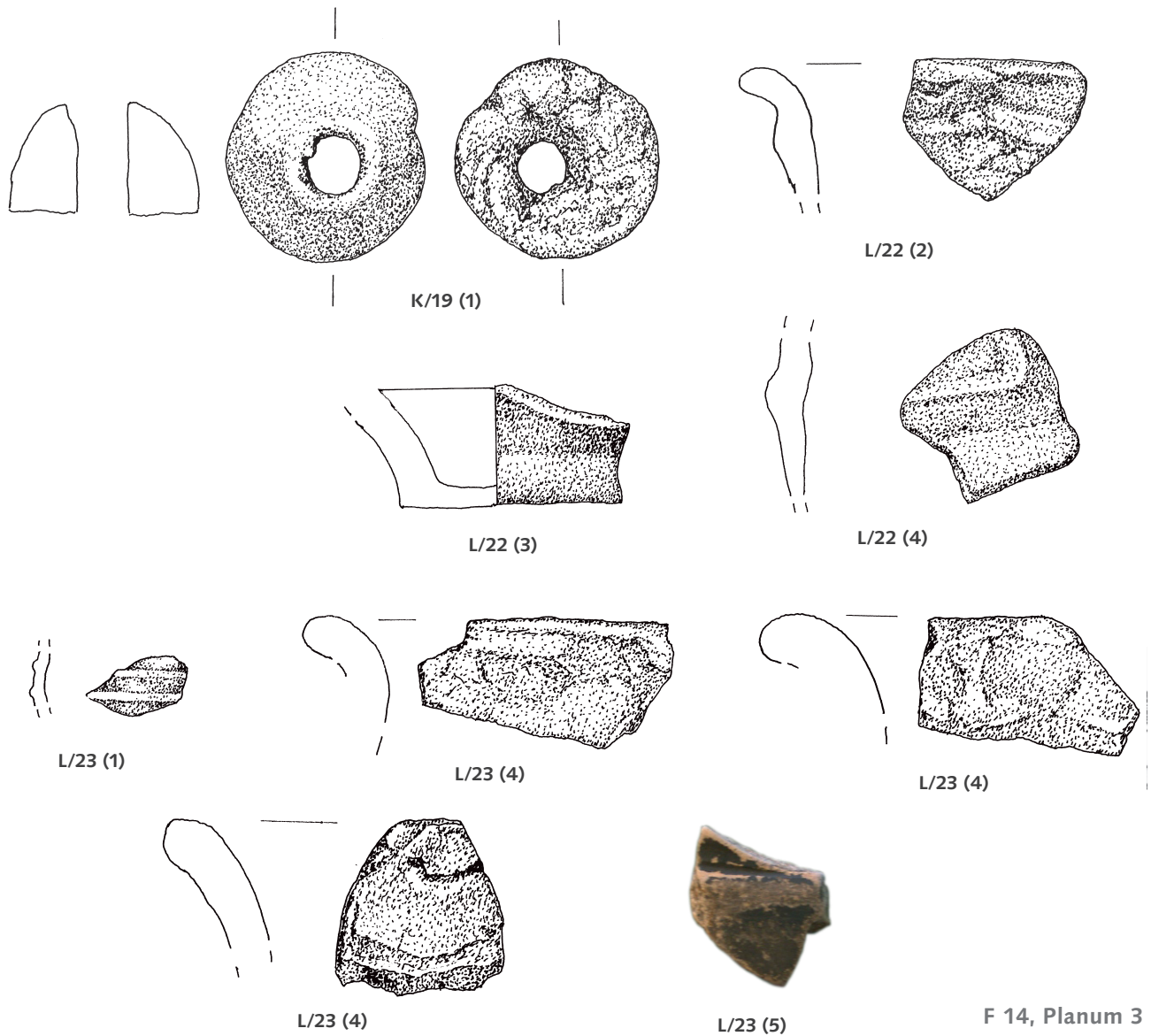

F 14, Planum 3

Herzebrock-Clarholz. Moorsenke (F 14). Planum 2. M/18 (1), M/22 (1), M/25 (3): Keramik. O/24 (2), O/28 (1): Glas.  
Planum 3. K/19 (1): Spinnwirtel. L/22 (2-4), L/23 (4, 5): Keramik. L/23 (1): Glasscherbe. – Alles Maßstab 1:1. Fotos o. Maßstab.

Tafel 64

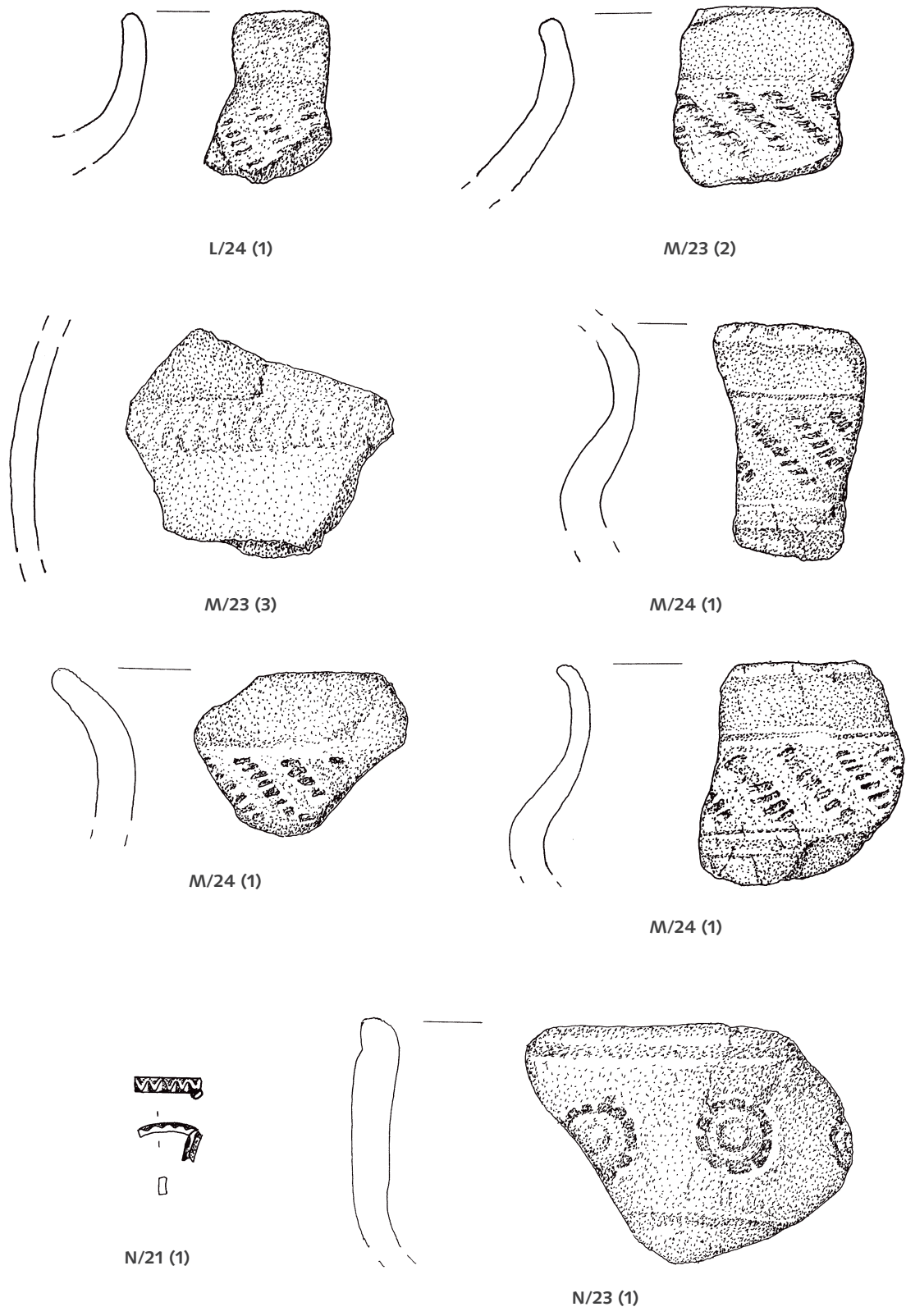

F 14, Planum 3

Herzebrock-Clarholz. Moorsenke (F 14). Planum 3. L/24 (1), M/23 (2, 3), M/24 (1), N/23 (1): Keramik. N/21 (1): Goldringfragment. – Alles Maßstab 1:1.

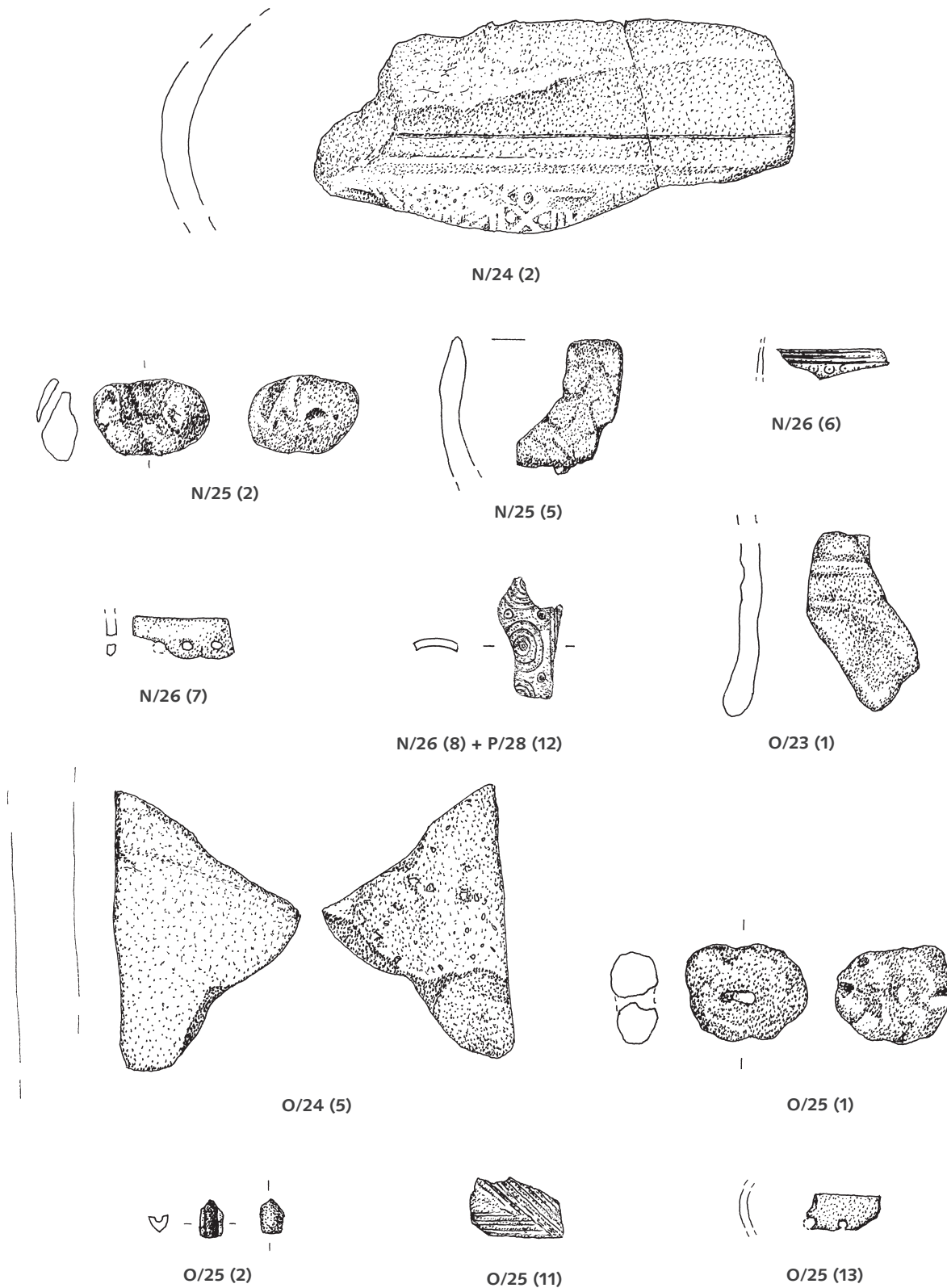

F 14, Planum 3

Herzebrock-Clarholz. Moorsenke (F 14). Planum 3. N/25 (2), O/25 (1, 2): Glasperlen. N/24 (2), N/25 (5), O/24 (5): Keramik. N/26 (8)+P/28 (12): Beinkammmetui. N/26 (6), O/25 (11): Beinkammfragmente. N/26 (7), O/25 (13): Beinkamm-Randborten(?). O/23 (1): Glasscherbe. Alles Maßstab 1:1.

Tafel 66

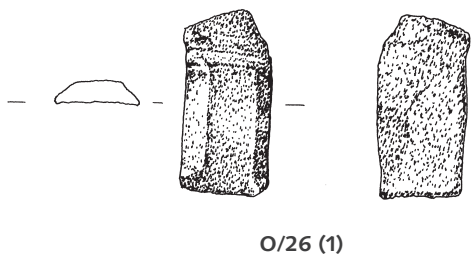

O/26 (1)

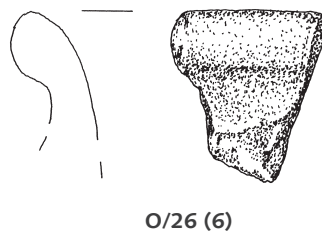

O/26 (6)

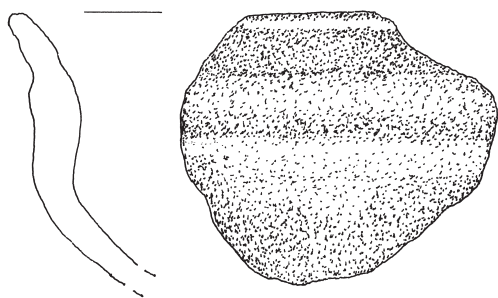

O/26 (7)

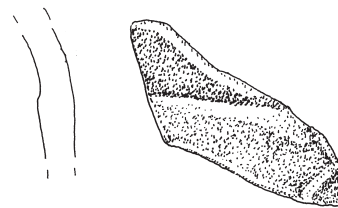

O/26 (9)



O/26 (15)



O/26 (15)

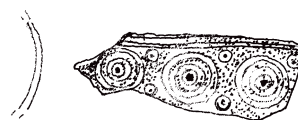

O/26 (17)

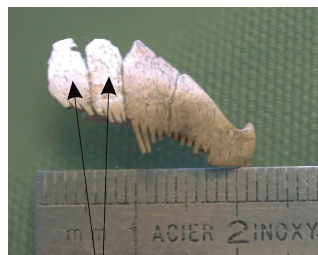

O/26 (18) + P/27-28 (2)

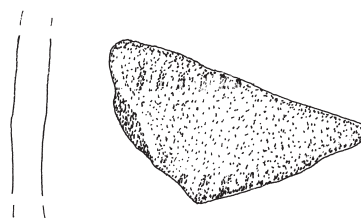

O/27 (9)



O/27 (11)



O/27 (11)

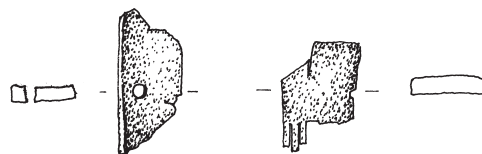

O/27 (13)

F 14, Planum 3

Herzebrock-Clarholz. Moorsenke (F 14). Planum 3. O/26 (1): Bronzeblech. O/26 (6, 7, 9), O/27 (9): Keramik. O/26 (15), O/27 (11, 13): Beinkammfragmente. O/26 (17): Beinkammmetui. O/26 (18) + P/27-28 (2): Miniatur-Beinkamm. – Alles Maßstab 1:1. Foto o. Maßstab.



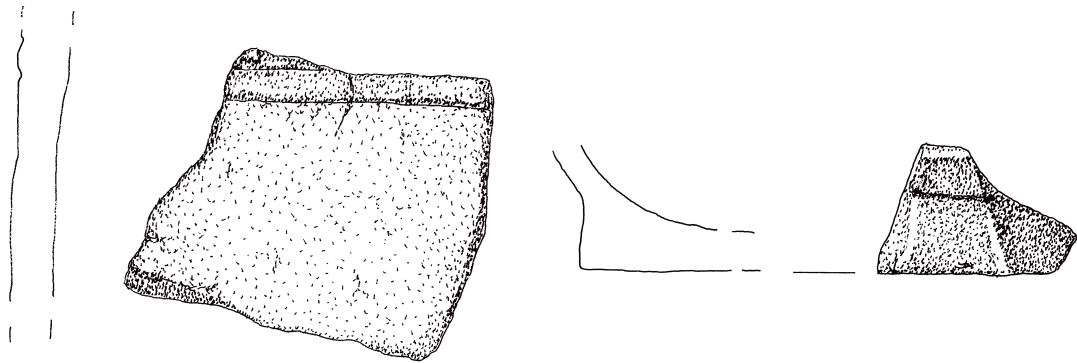

P/25 (4)

P/25 (5)

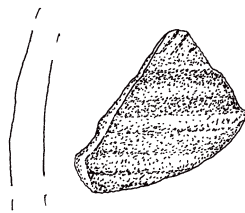

P/25 (6)

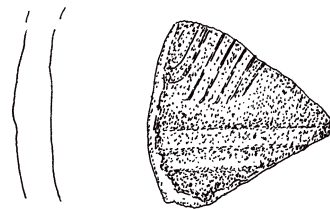

P/25 (6)

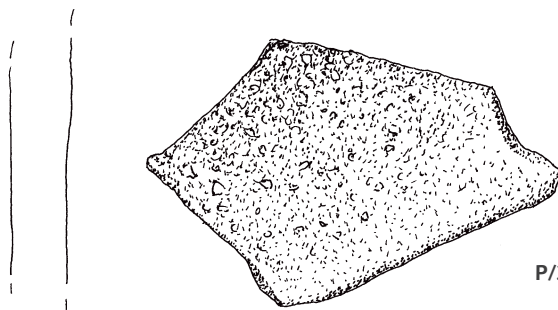

P/25 (7)

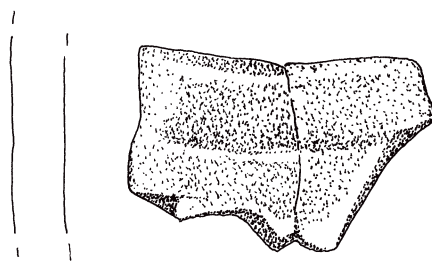
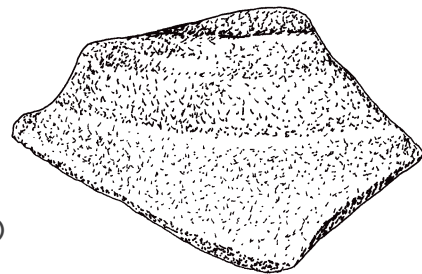

P/25 (7)

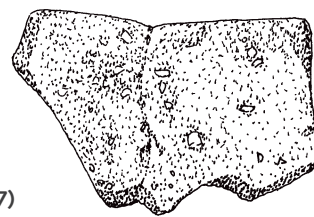

P/25 (9)



P/25 (11)

F 14, Planum 3

# Tafel 68



P/27 (1)

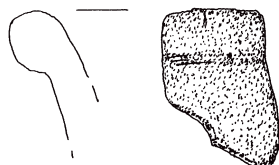

P/27 (6)



P/27 (10)

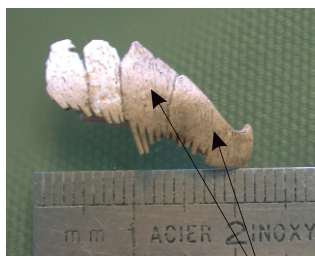

Q/26 (18) + P/27-28 (2)



P/27-28 (3)

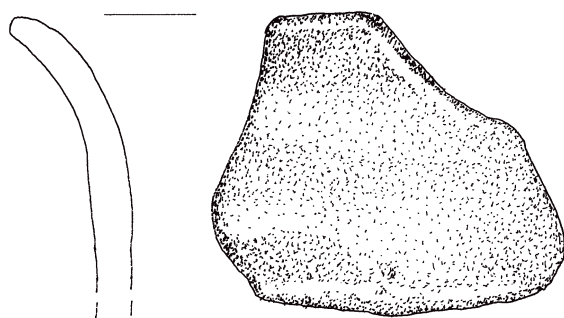

P/28 (7)

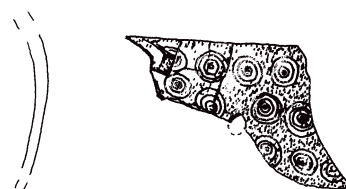

P/28 (11)



P/28 (13)



N/26 (8) + P/28 (12)

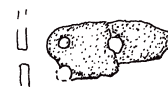

P/28 (14)

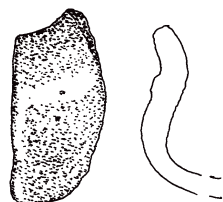

P/29 (1)



Q/28 (1)

F 14, Planum 3

Herzebrock-Clarholz. Moorsenke (F 14). Planum 3. P/27 (1), P/29 (1): Glasbecherscherben. P/27 (6, 10), P/28 (7): Keramik. Q/26 (18) + P/27-28 (2): Miniatur-Beinkamm. P/27-28 (3), P/28 (14): Beinkamm-Randborte(?). P/28 (11, 13), Q/28 (1): Beinkammfragmente. N/26 (8) + P/28 (12), P/28 (14): Beinkammmetui. – Alles Maßstab 1:1. Foto o. Maßstab.

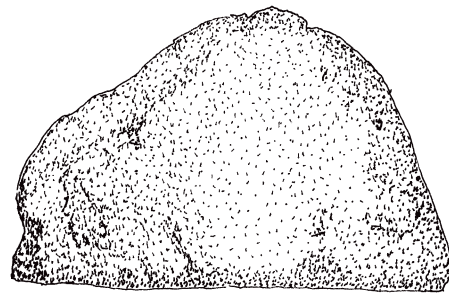
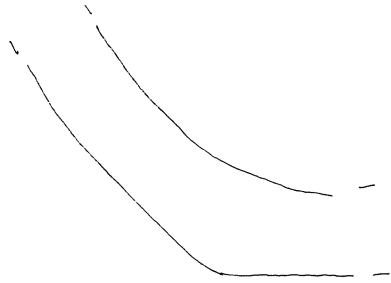

M/16 (1)

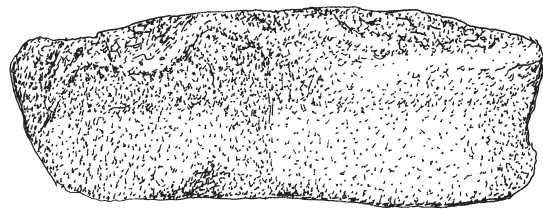
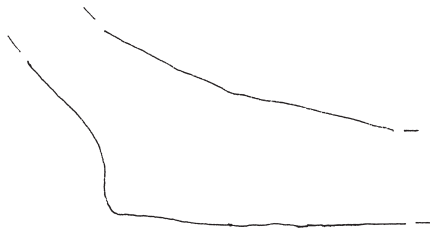

M/25 (1)

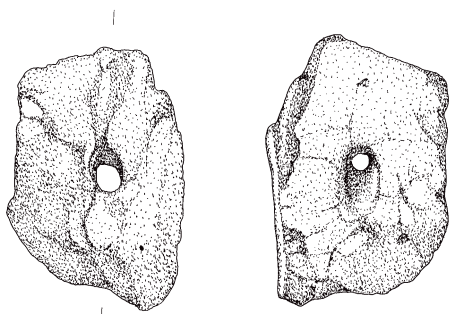

M/17 (1)

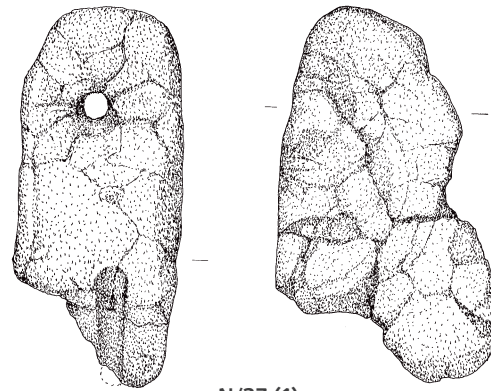

N/27 (1)

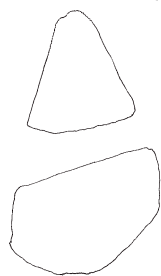

F 14, Planum 4

Tafel 70

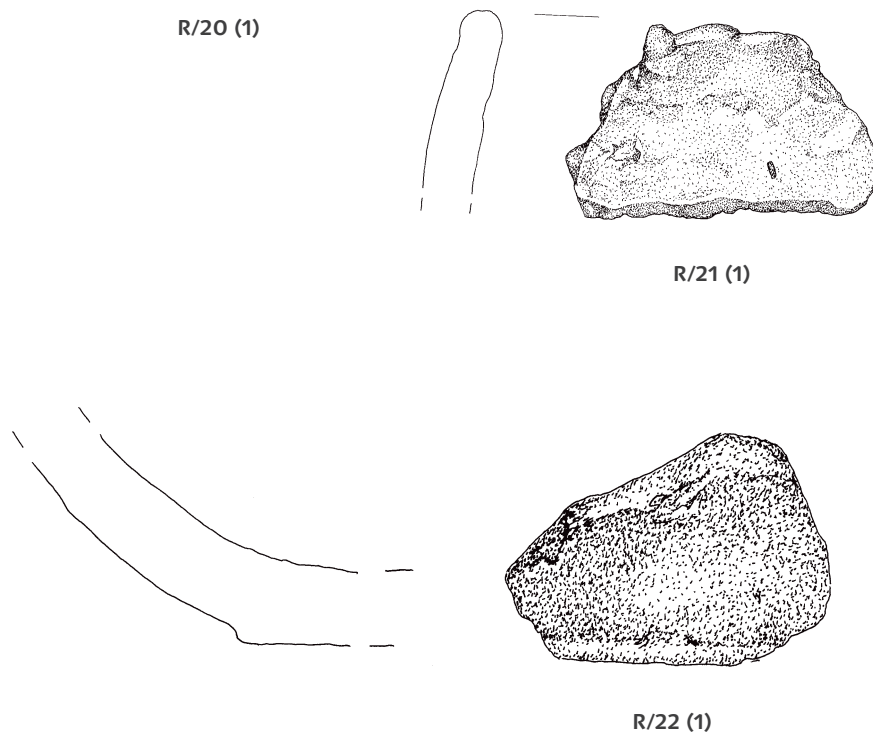
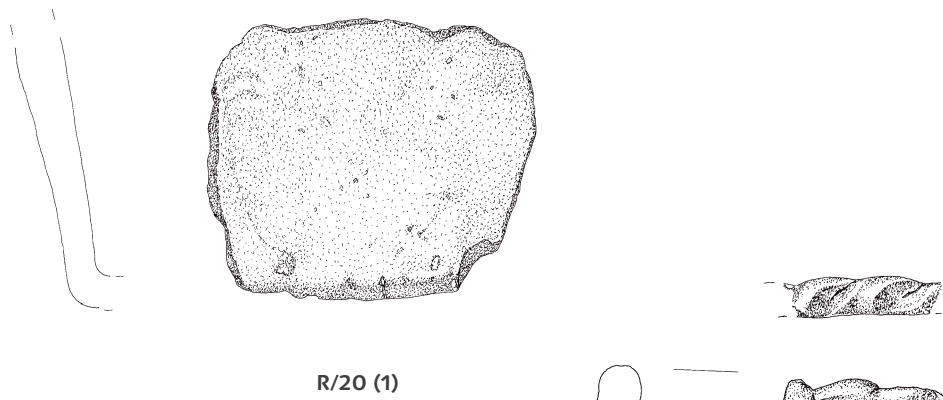
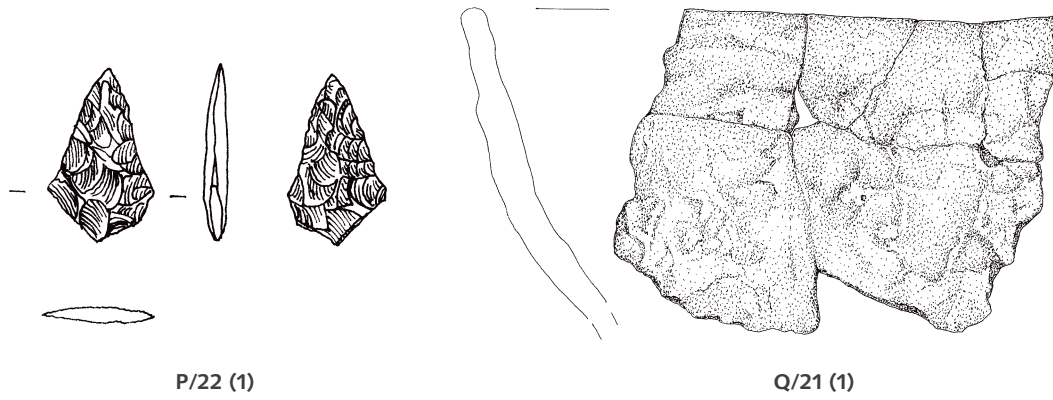

F 14, Planum 4

Herzebrock-Clarholz. Moorsenke (F 14). Planum 4. P/22 (1): Feuerstein-Pfeilspitze. – Maßstab 1:1.  
Q/21 (1), R/20 (1), R/21 (1), R/22 (1): Keramik. – R/22 (1): Maßstab 1:1, alle anderen Maßstab 1:2.

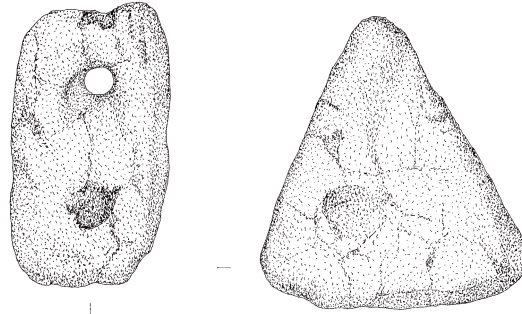

Q/25 (1)

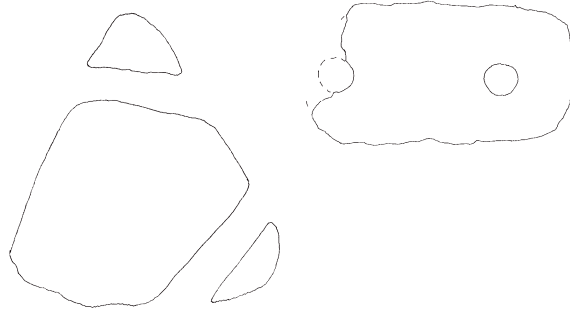

F 14, Planum 4

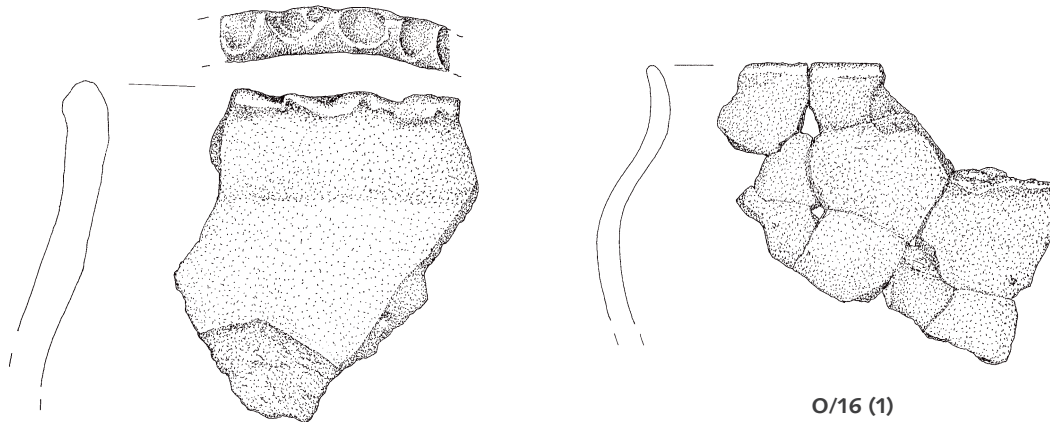

O/15 (1)

O/16 (1)

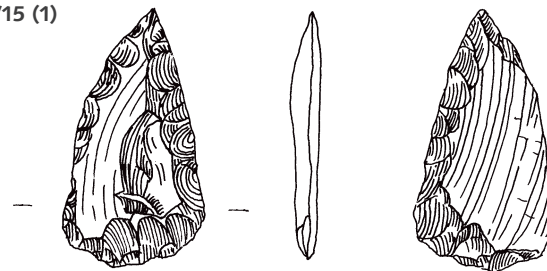

O/17 (2)

F 14, Planum 5



Tafel 72

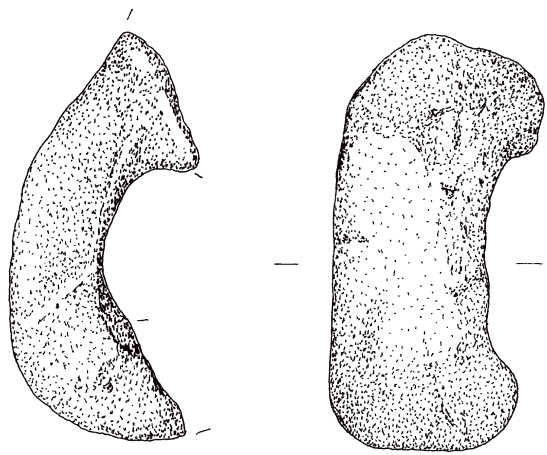

Q/15 (1)

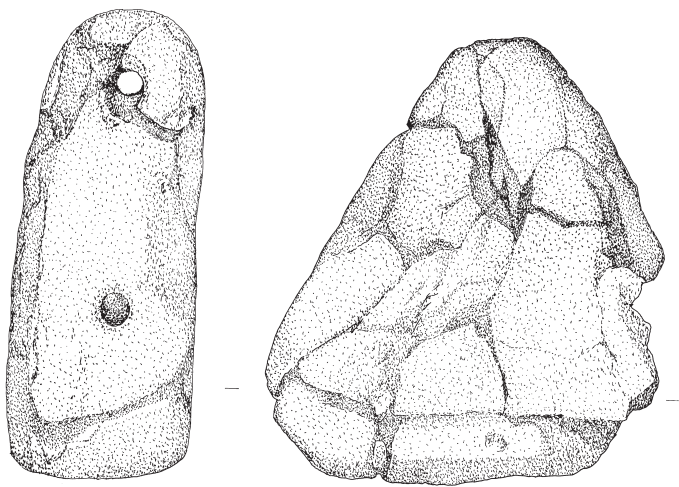

Q/25 (1)

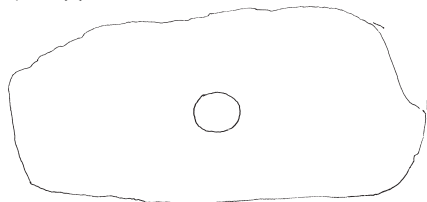

P-Q/26-27 (1)

F 14, Planum 5

Herzebrock-Clarholz. Moorsenke (F 14). Planum 5. Q/15 (1): Keramikhenkel. – Maßstab 1:1. Q/25 (1): Tongewicht. – Maßstab 1:2. P-Q/26-27 (1): Reibstein (Granit). – Maßstab 1:3.



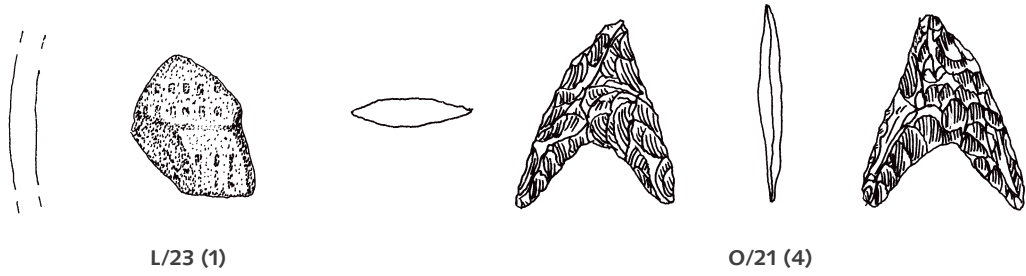

L/23 (1)

O/21 (4)

F 14, Schnitt B

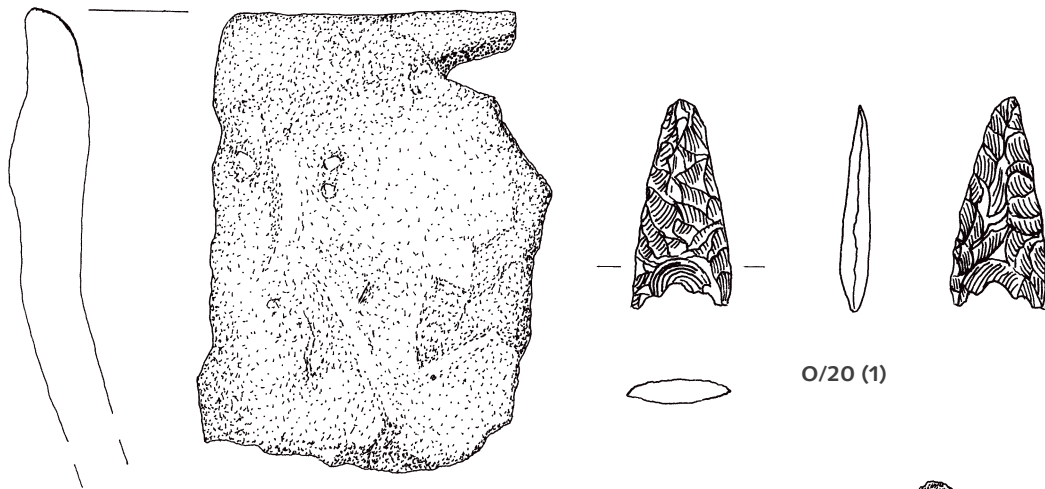

K/21 (1)

O/20 (1)

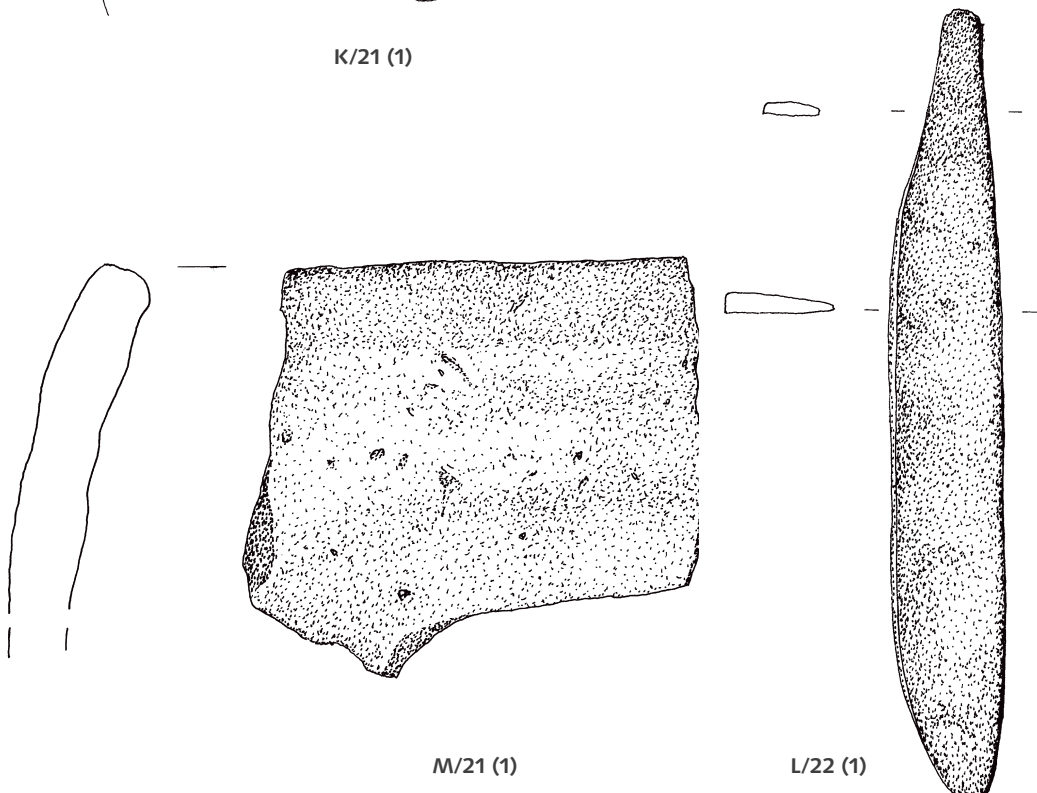

M/21 (1)

L/22 (1)

F 14, Profilsteg

Herzebrock-Clarholz. Moorsenke (F 14). Schnitt B. L/23 (1): Keramik. O/21 (4): Feuerstein-Pfeilspitze. Profilsteg. K/21 (1), M/21 (1): Keramik. L/22 (1): Eisenmesser. O/20 (1): Feuerstein-Pfeilspitze. – Alles Maßstab 1:1.

Tafel 74

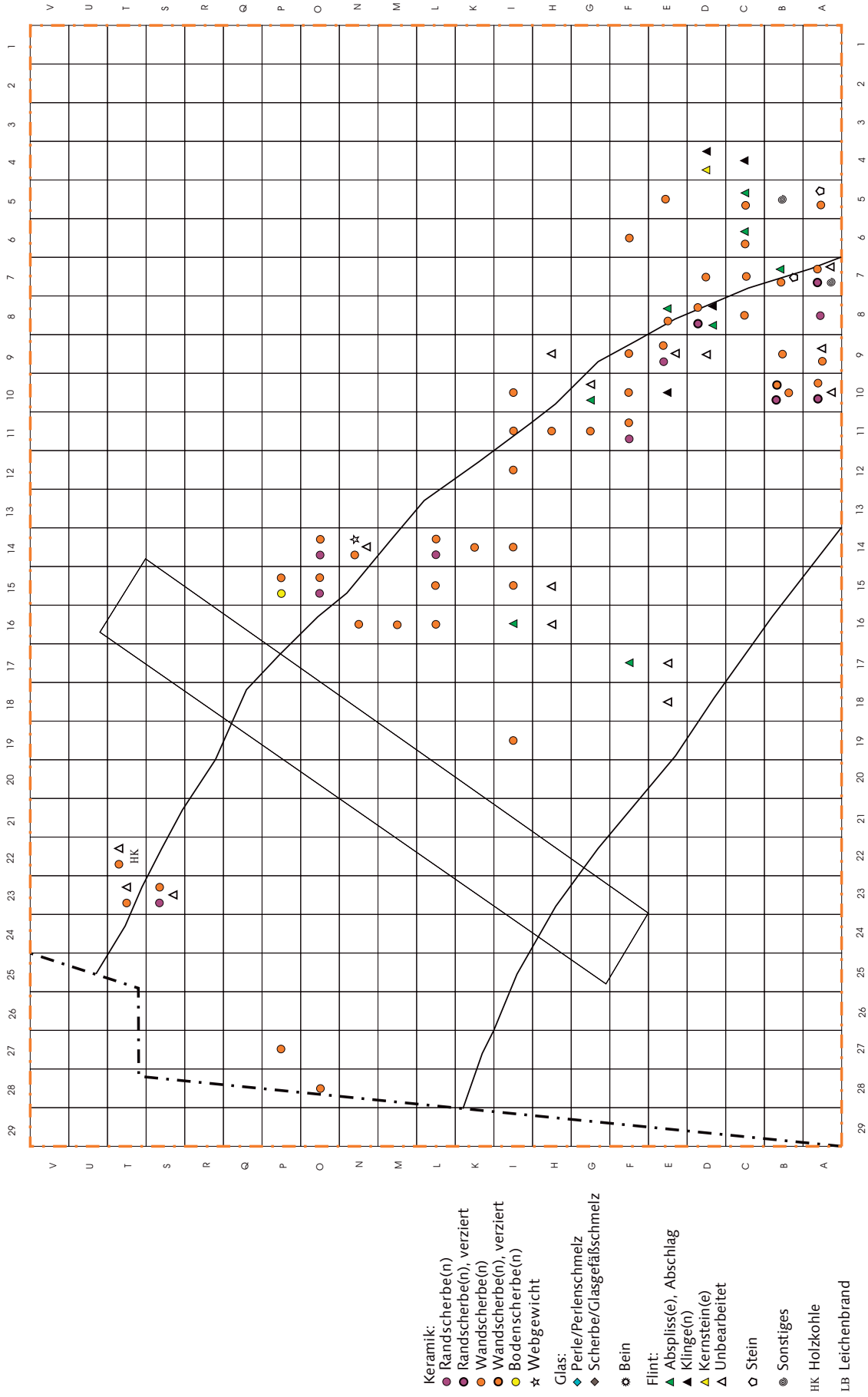

Herzebrock-Clarholz, DKZ 4015,10. Moorsenke F 14. Planum O: Fundverteilung. – Maßstab 1:150.

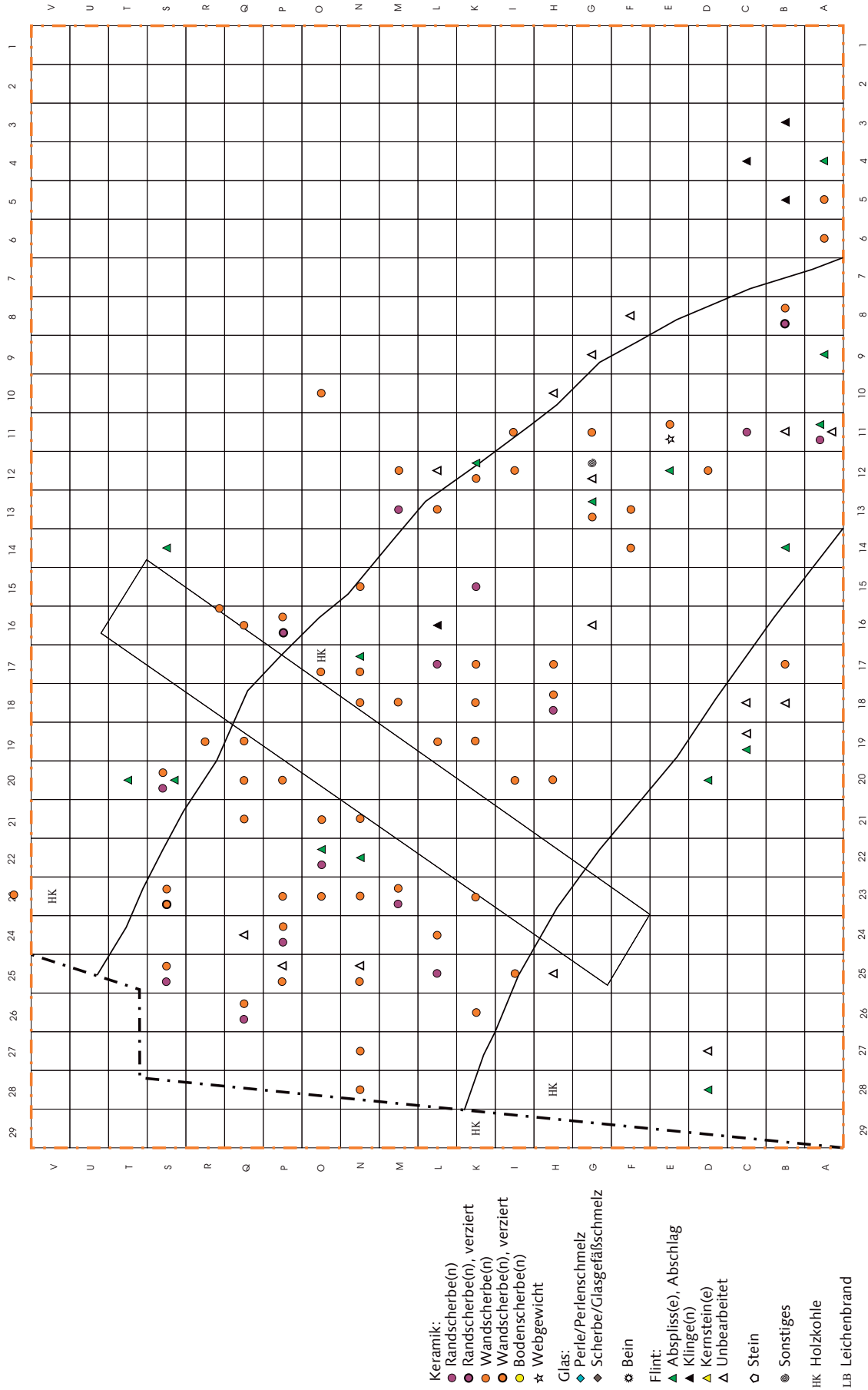

Herzebrock-Clarholz, DKZ 4015,10. Moorsenke F 14. Planum 1: Fundverteilung. – Maßstab 1:150.

Tafel 76

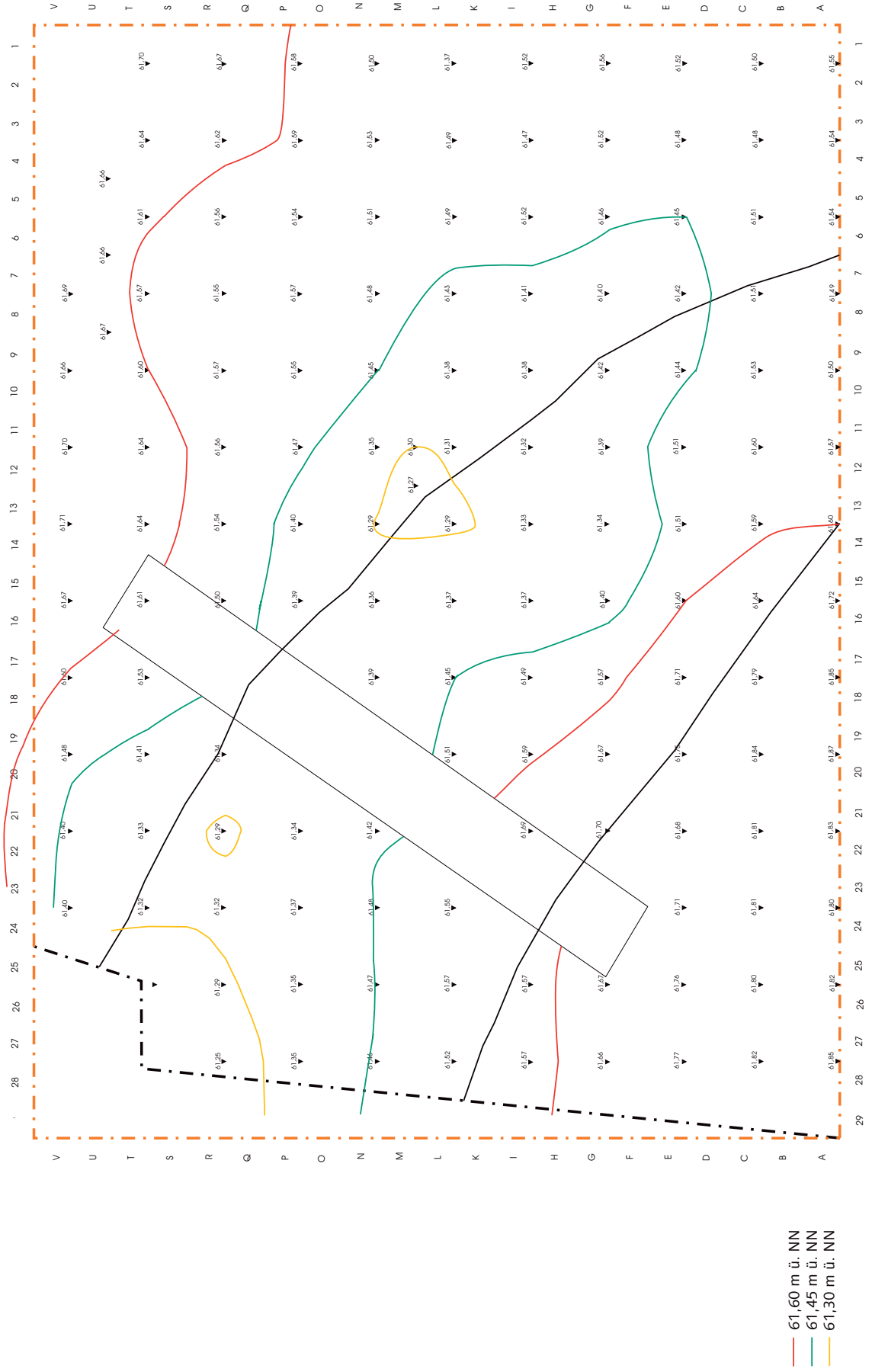

Herzebrock-Clarholz, DKZ 4015,10. Moorsenke F 14. Planum 1: Nivellement mit Höhenlinien. – Maßstab 1:150.

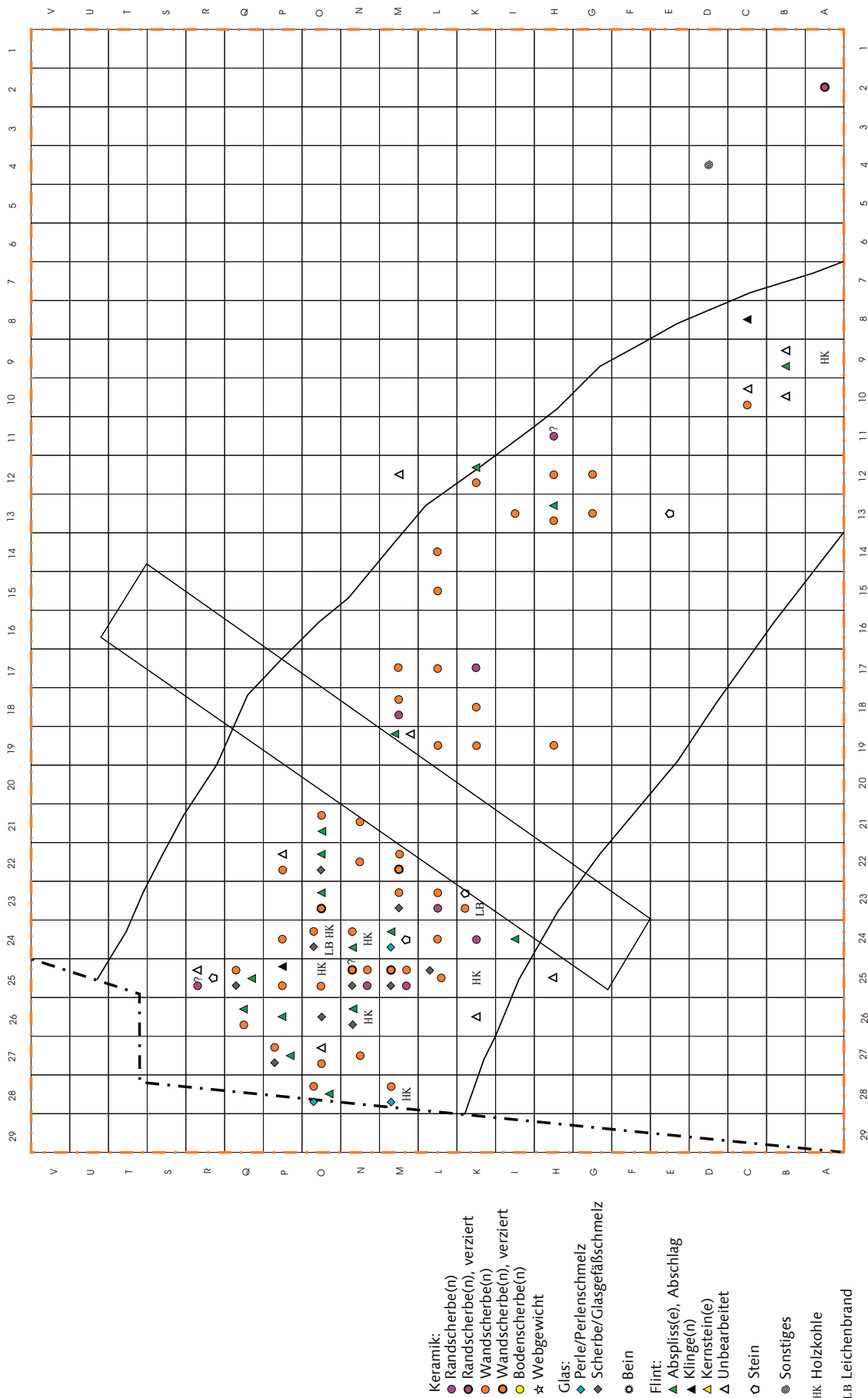

Herzebrock-Clarholz, DKZ 4015,10. Moorsenke F 14. Planum 2: Fundverteilung. – Maßstab 1:150.

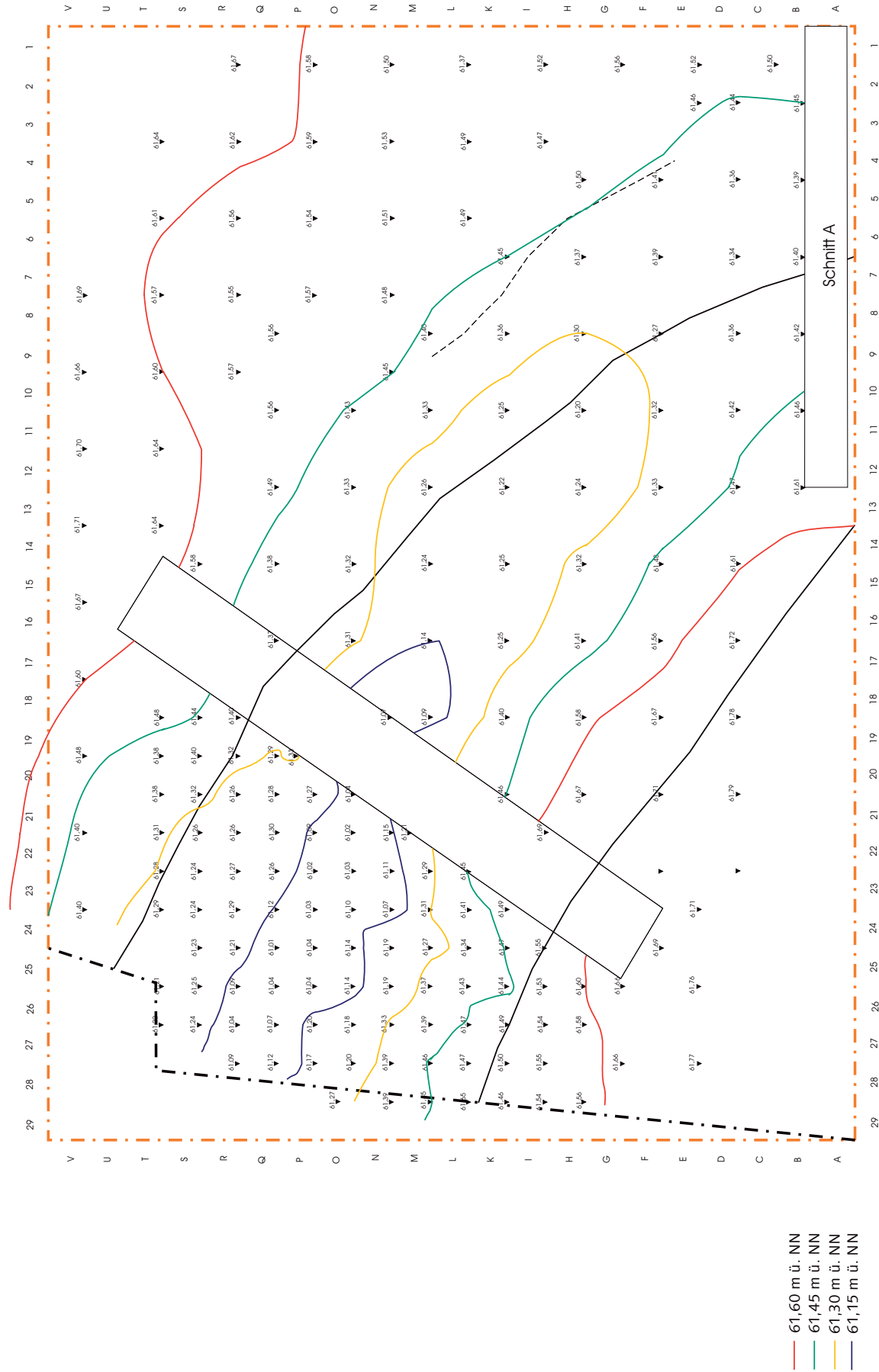

Herzebrock-Clarholz, DKZ 4015,10. Moorsenke F 14. Planum 2: Nivellement mit Höhenlinien. – Maßstab 1:150.



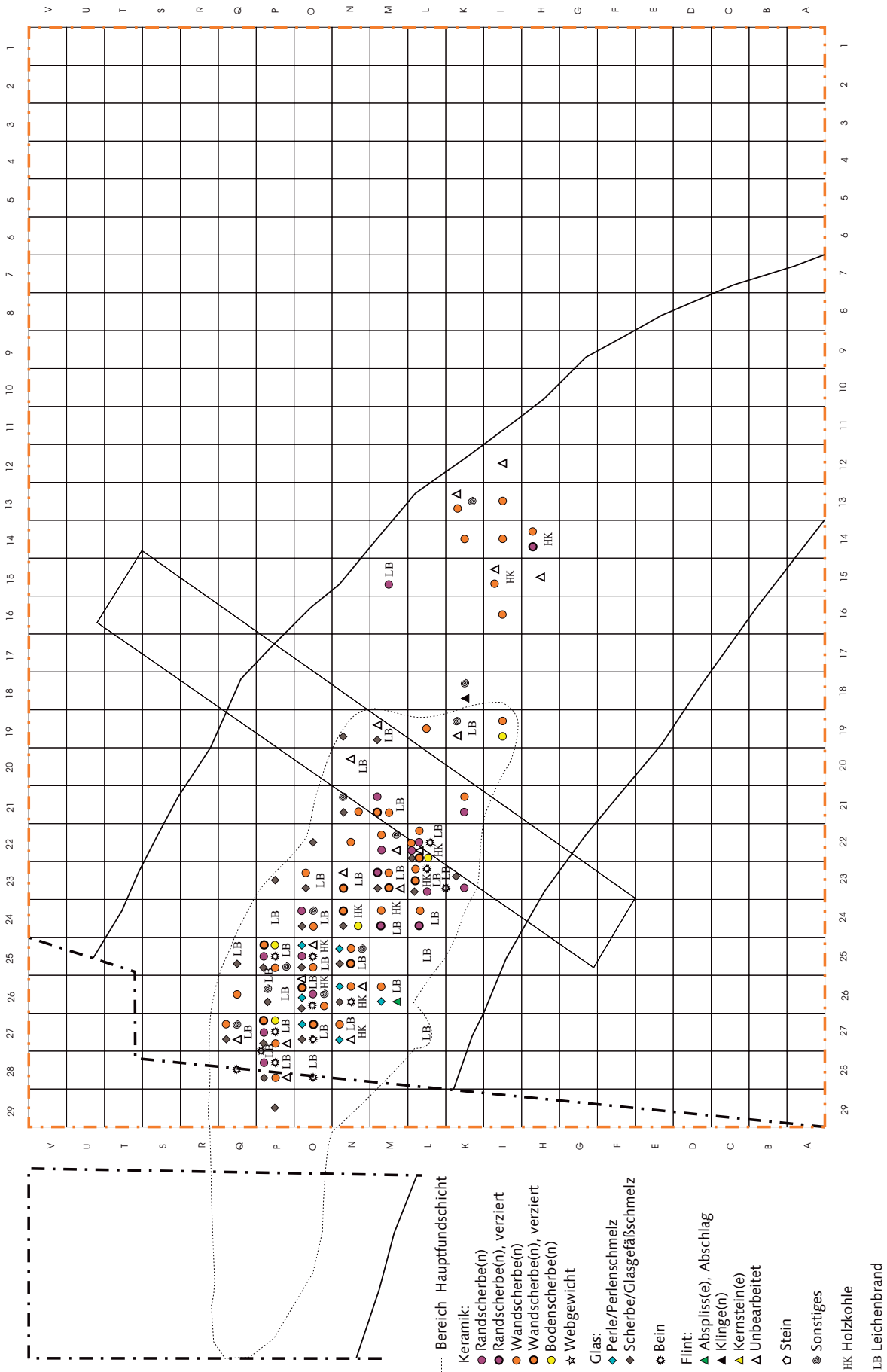

Herzebrock-Clarholz, DKZ 4015,10. Moorsenke F 14. Planum 3 (und Profilsteig Pl. II-III): Fundverteilung. – Maßstab 1:150.

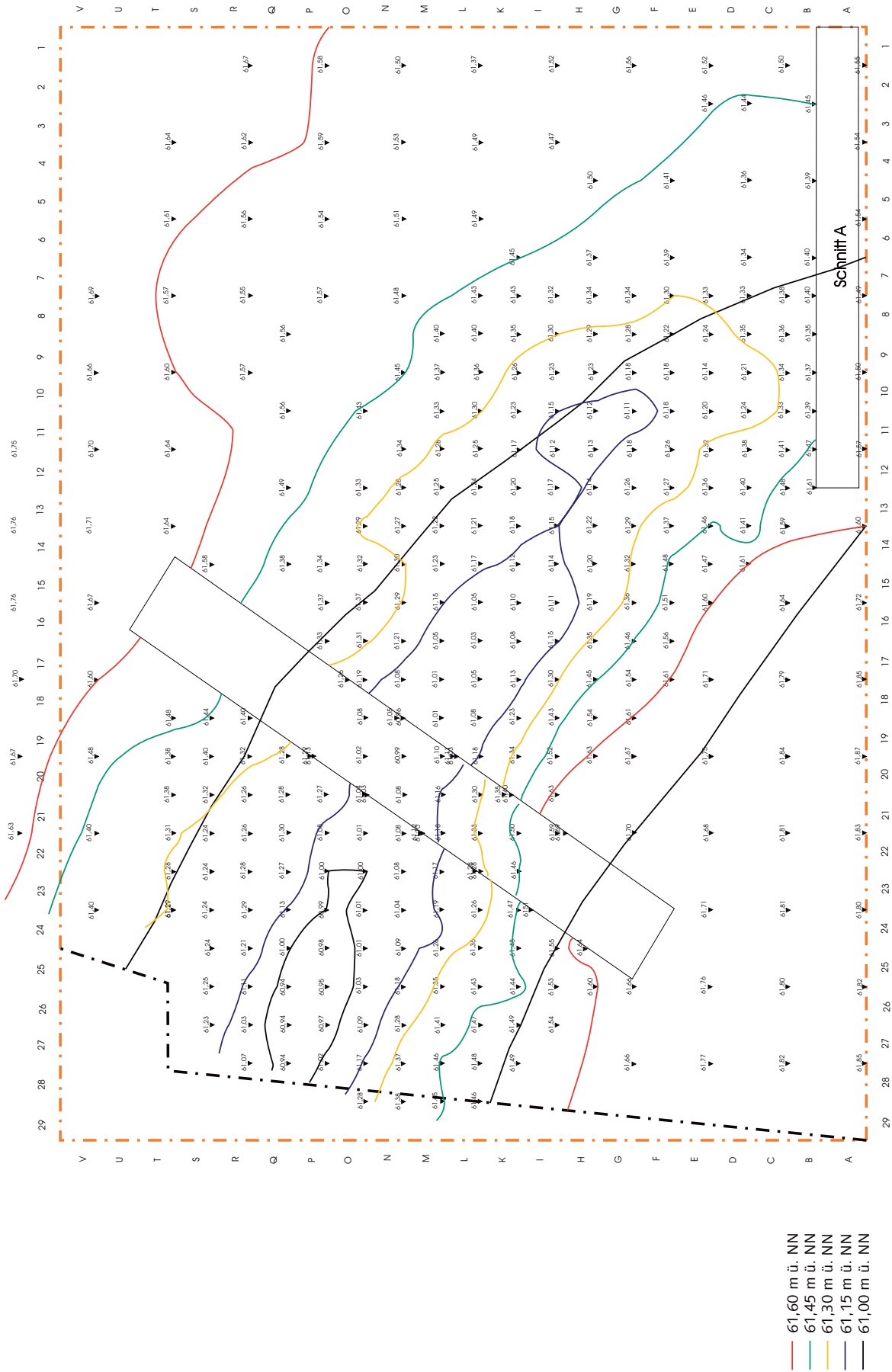

- 61,60 m ü. NN
- 61,45 m ü. NN
- 61,30 m ü. NN
- 61,15 m ü. NN
- 61,00 m ü. NN

Herzebrock-Clarholz, DKZ 4015,10. Moorsenke F 14. Planum 3 und Profilsteg (Pl. III): Nivellement mit Höhenlinien. – Maßstab 1:150.

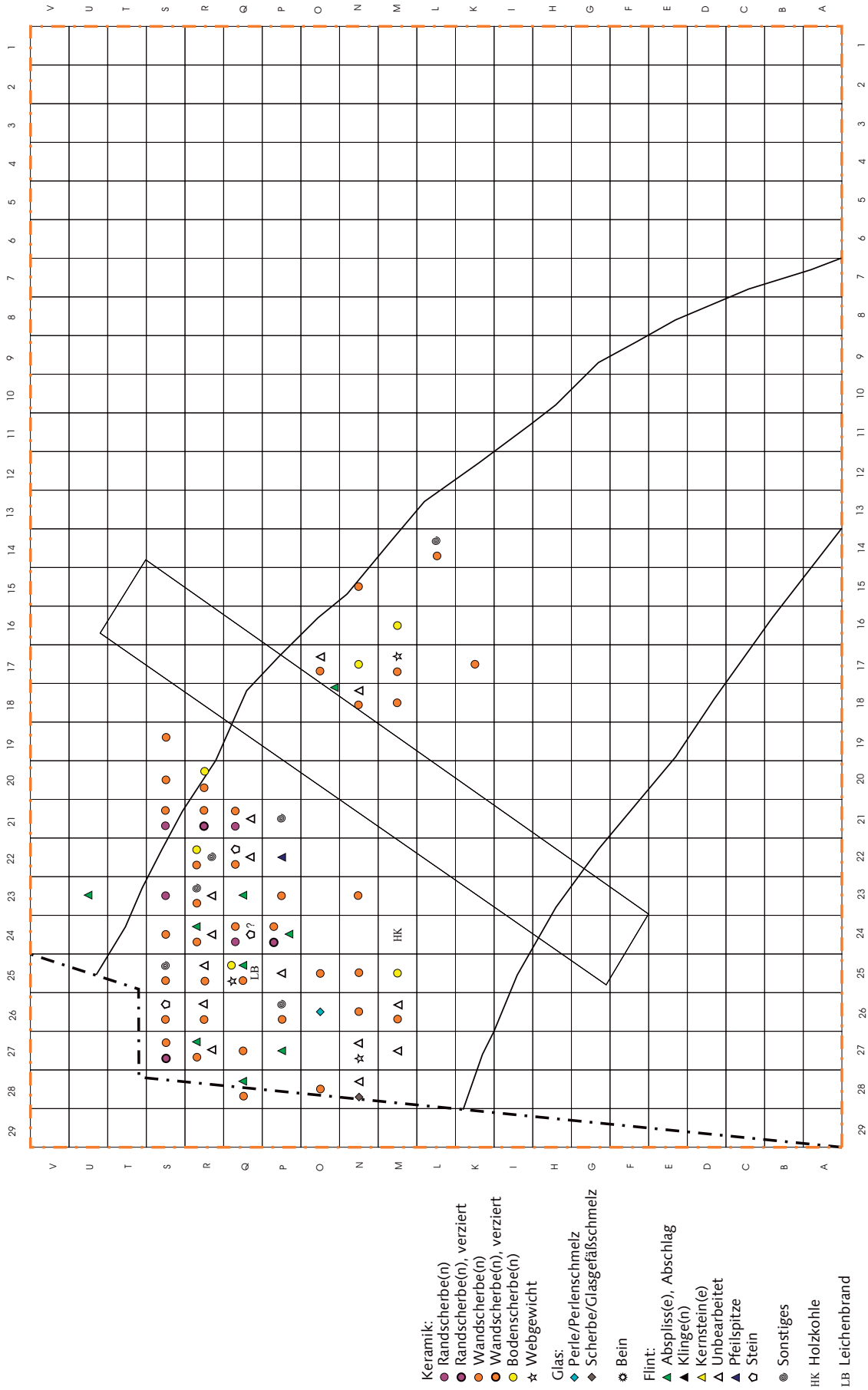

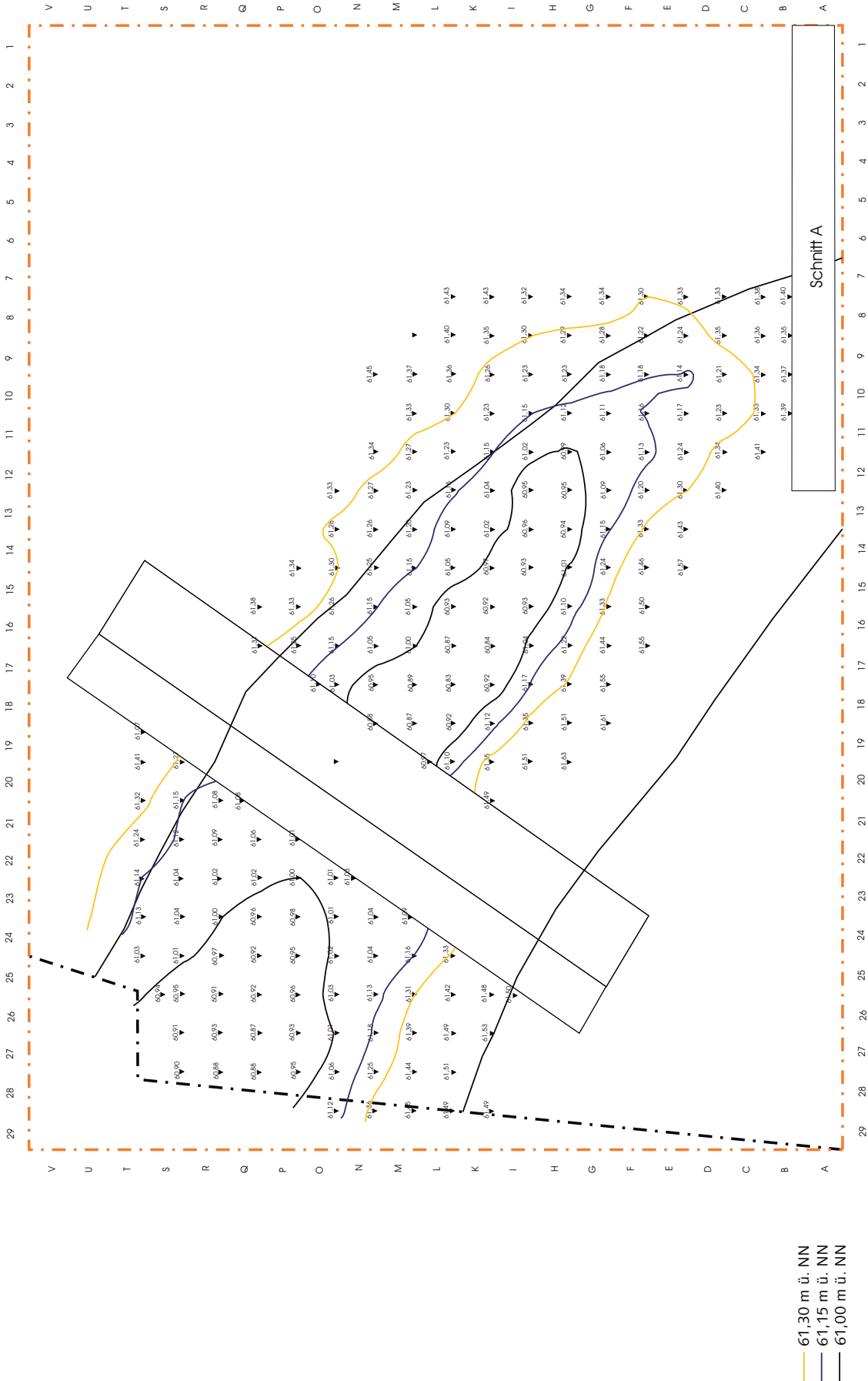

- 61,30 m ü. NN
- 61,15 m ü. NN
- 61,00 m ü. NN

Herzebrock-Clarholz, DKZ 4015,10. Moorsenke F 14. Planum 4: Nivellement mit Höhenlinien. – Maßstab 1:150.

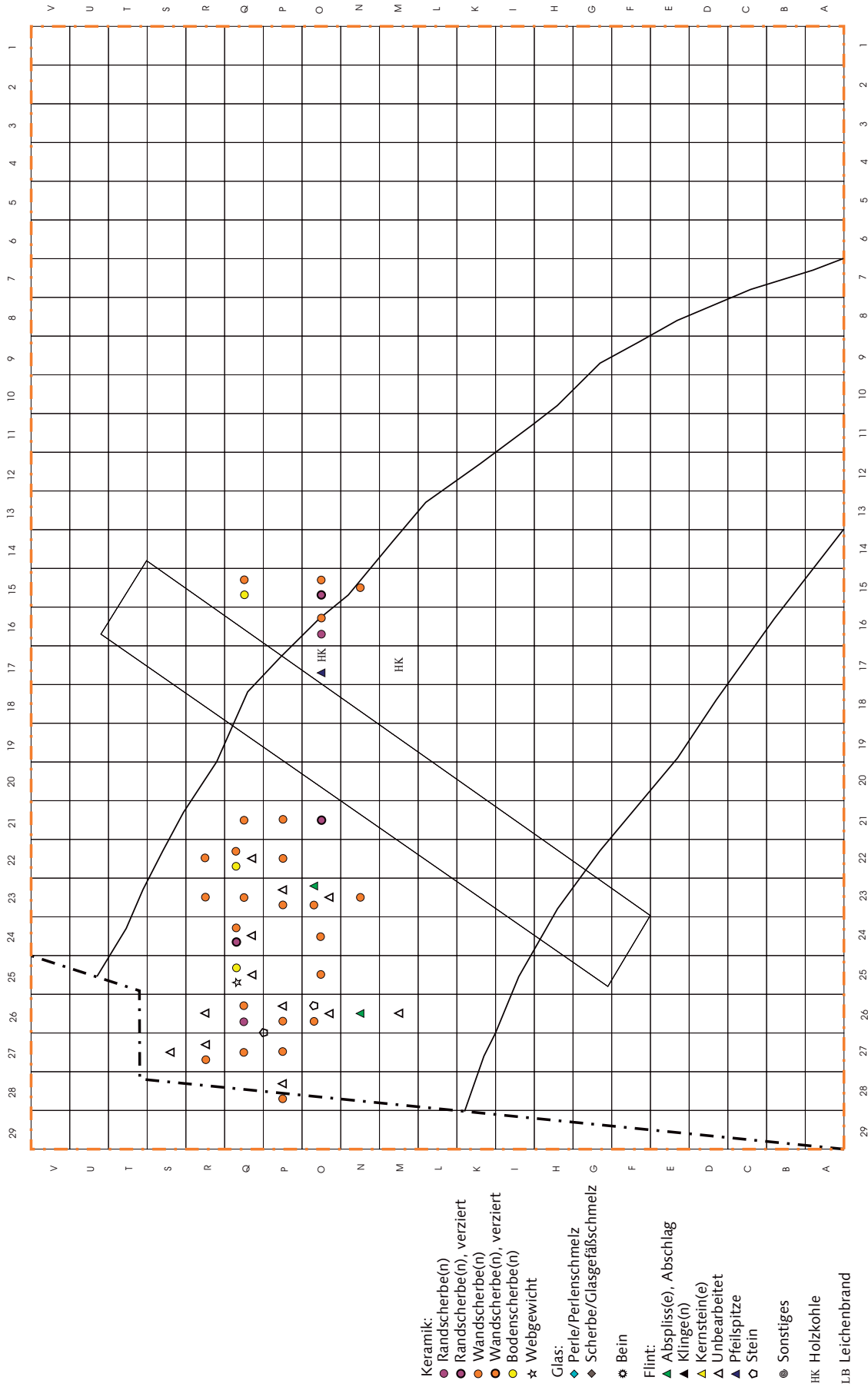

Herzebrock-Clarholz, DKZ 4015,10. Moorsenke F 14. Planum 5: Fundverteilung. – Maßstab 1:150.

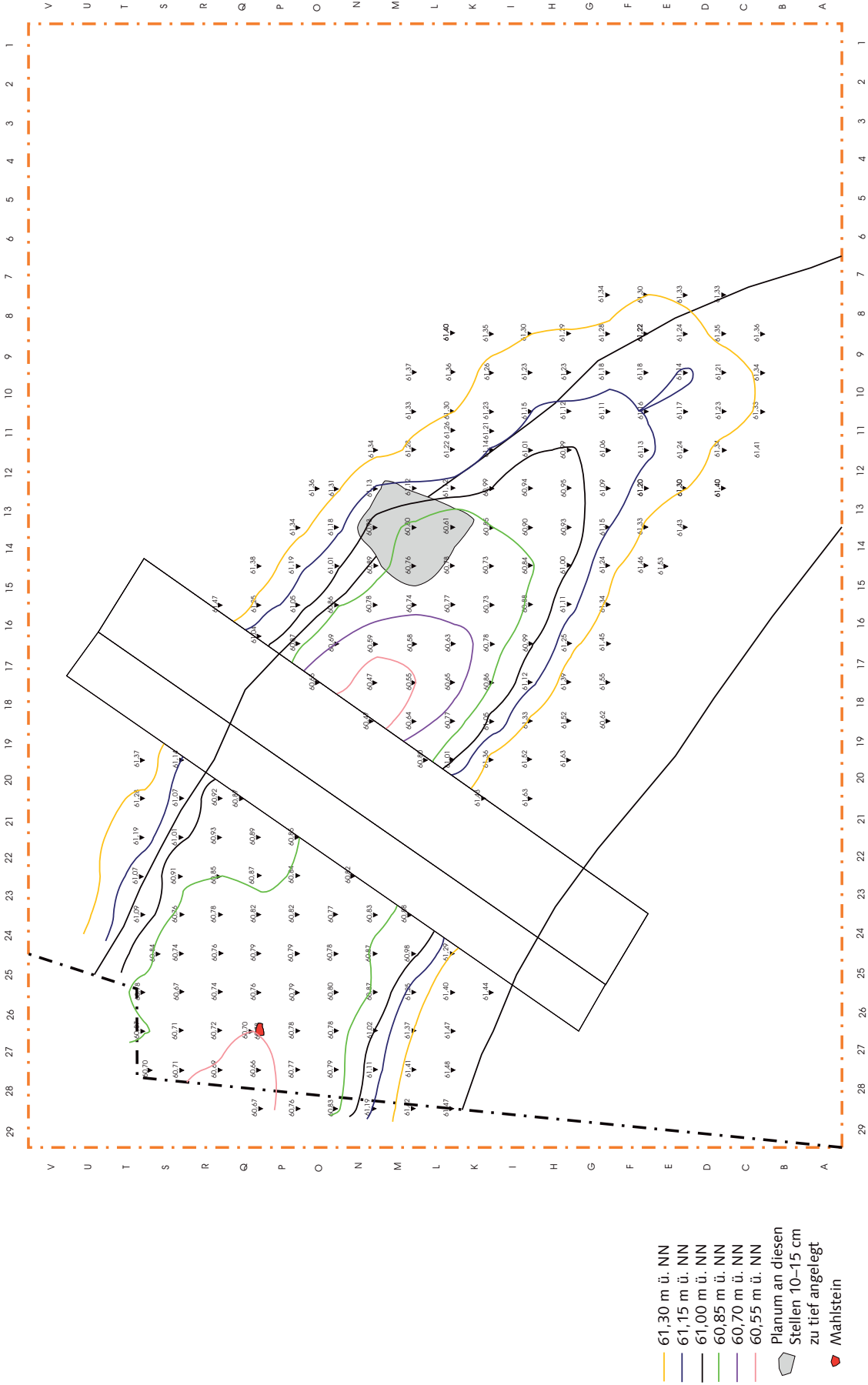

Herzebrock-Clarholz, DKZ 4015,10. Moorsenke F 14. Planum 5. Nivellement mit Höhenlinien. – Maßstab 1:150.



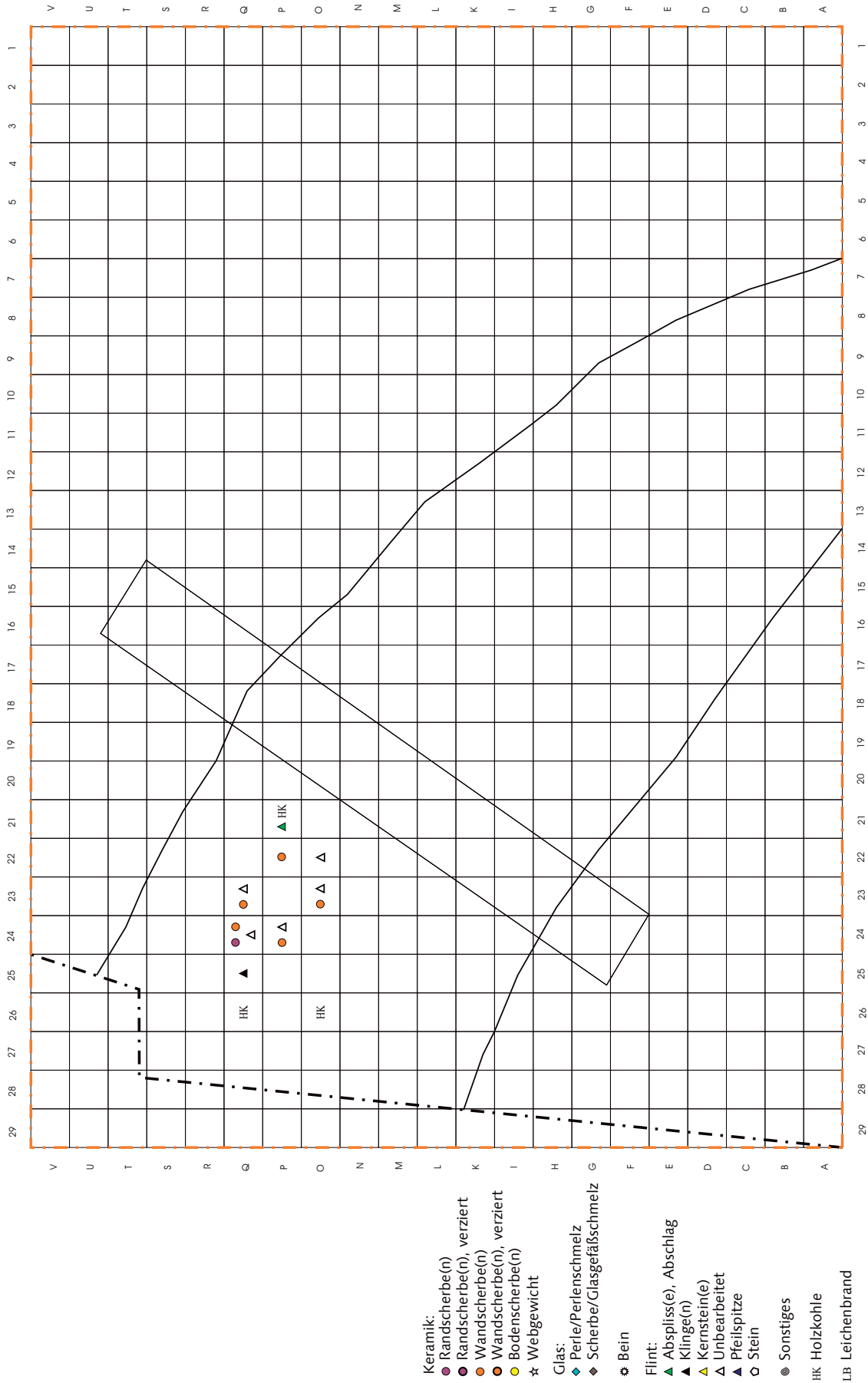

Herzebrock-Clarholz, DKZ 4015,10. Moorsenke F 14. Planum 6: Fundverteilung. – Maßstab 1:150.

Tafel 86

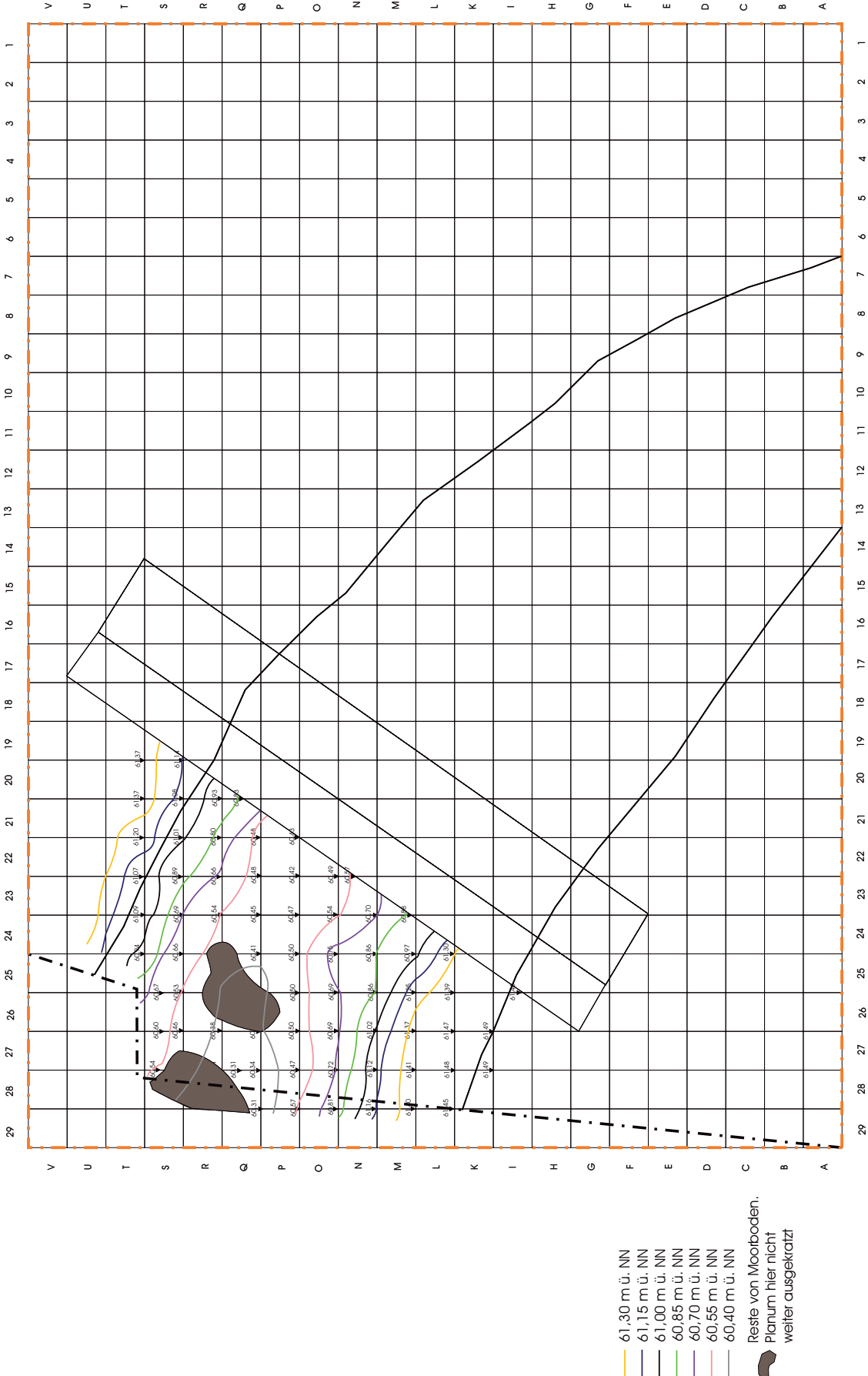

Herzebrock-Clarholz, DKZ 4015,10. Moorsenke F 14. Planum 6: Nivellement mit Höhenlinien. – Maßstab 1:150.

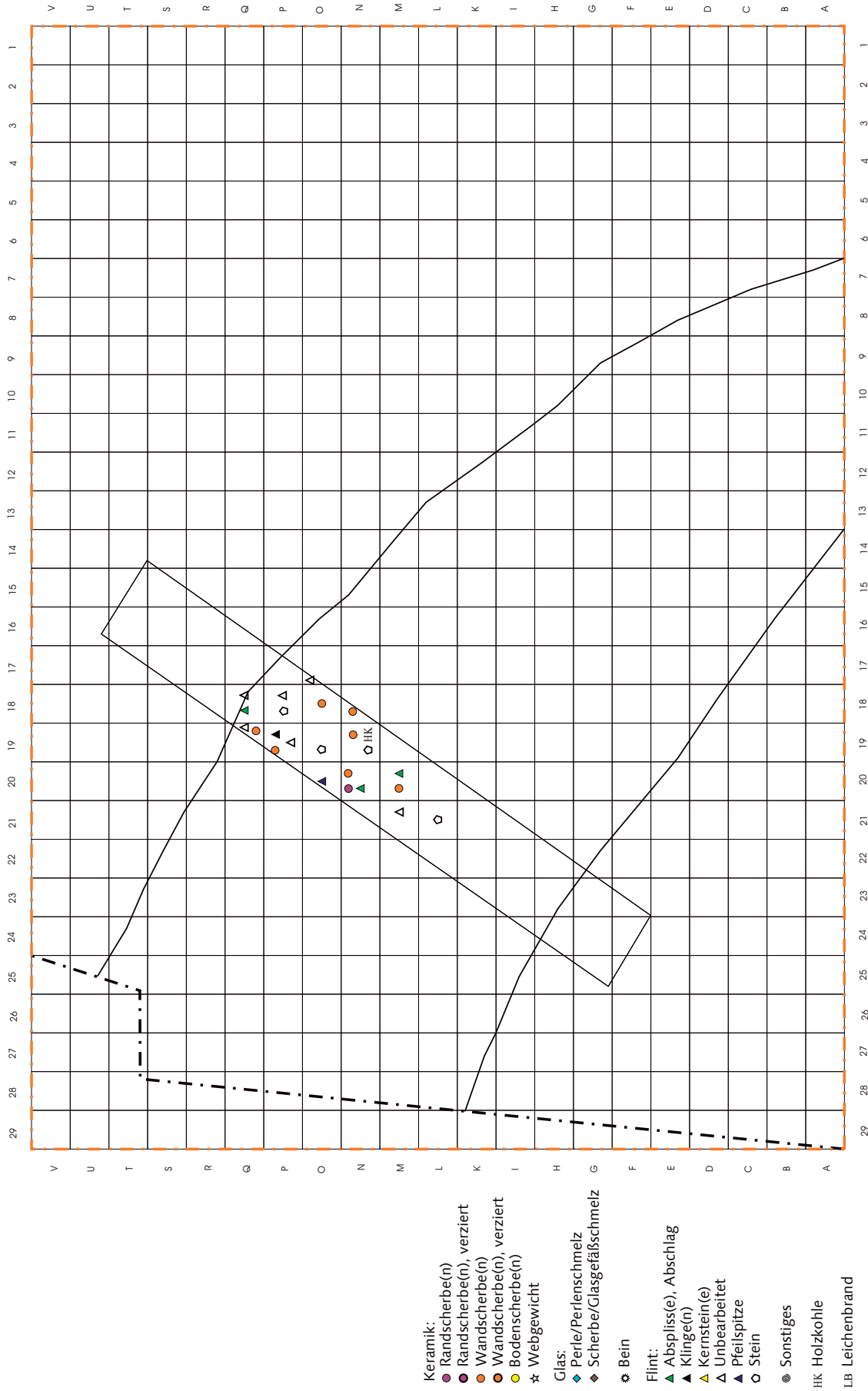

Herzebrock-Clarholz, DKZ 4015,10. Moorsenke F 14. Profilsteg: Funde unterhalb der Hauptfundschicht (Pl. III-V). – Maßstab 1:150.

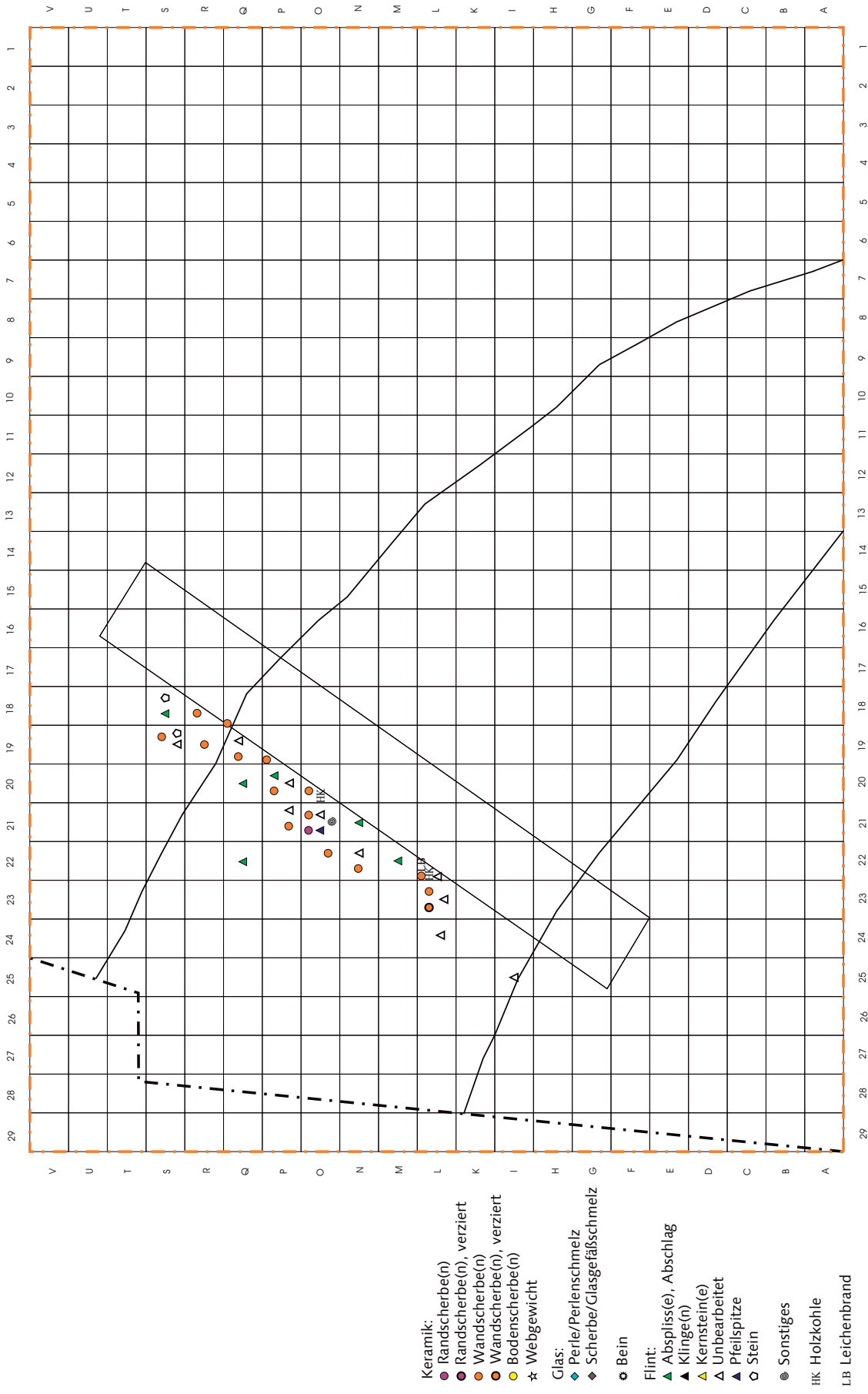

Herzebrock-Clarholz, DKZ 4015,10. Moorsenke F 14. Schnitt B: Fundverteilung. – Maßstab 1:150.

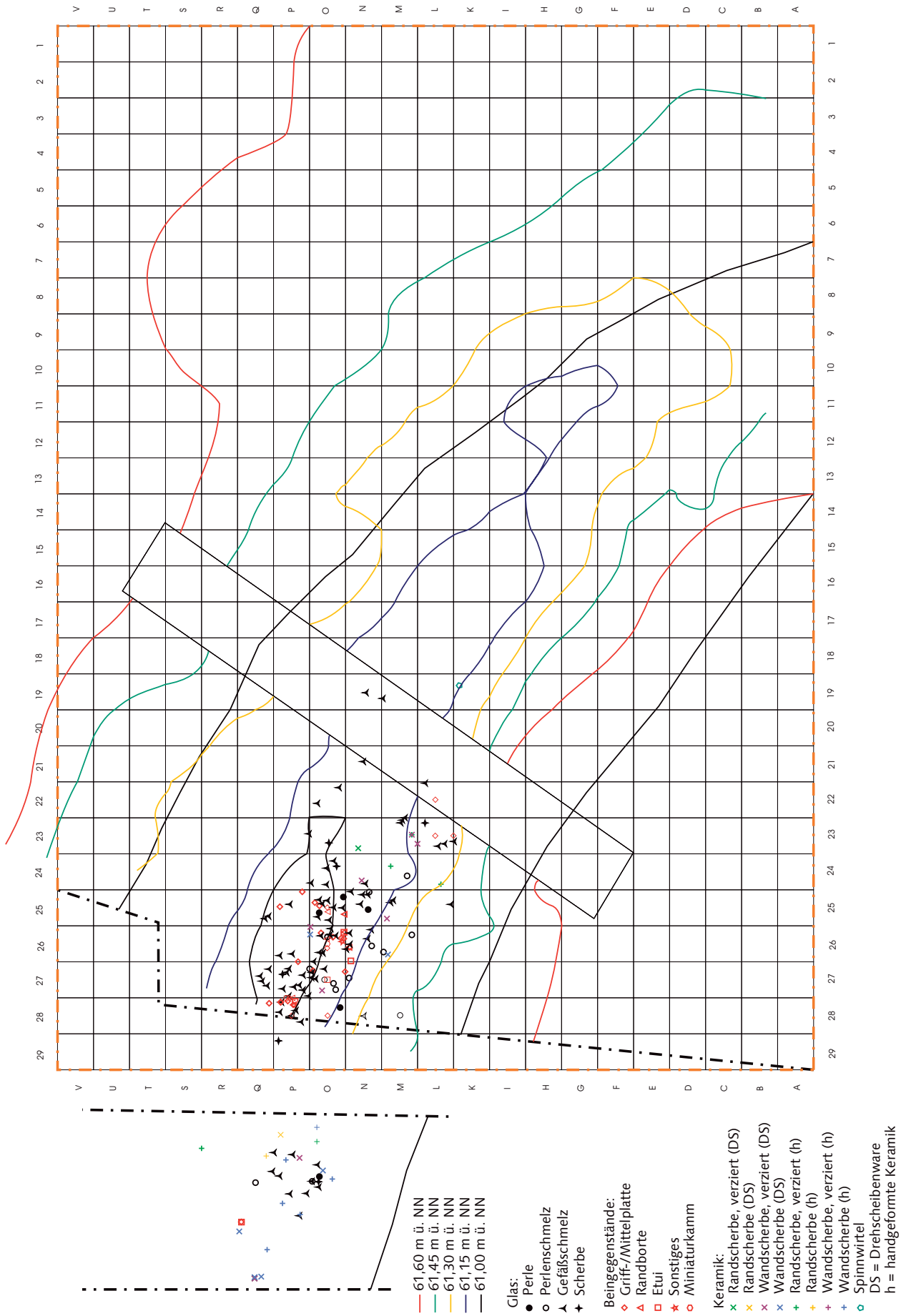

Herzebrock-Clarholz, DKZ 4015,10. Moorsenke F 14. Verteilung von Glas, Beigegenständen und Keramik innerhalb der Hauptfundschicht (dünne Signaturen: keine exakte Einmessung, in Fläche A nur genau lokalisierte Keramik). – Maßstab 1:150.

# Tafel 90

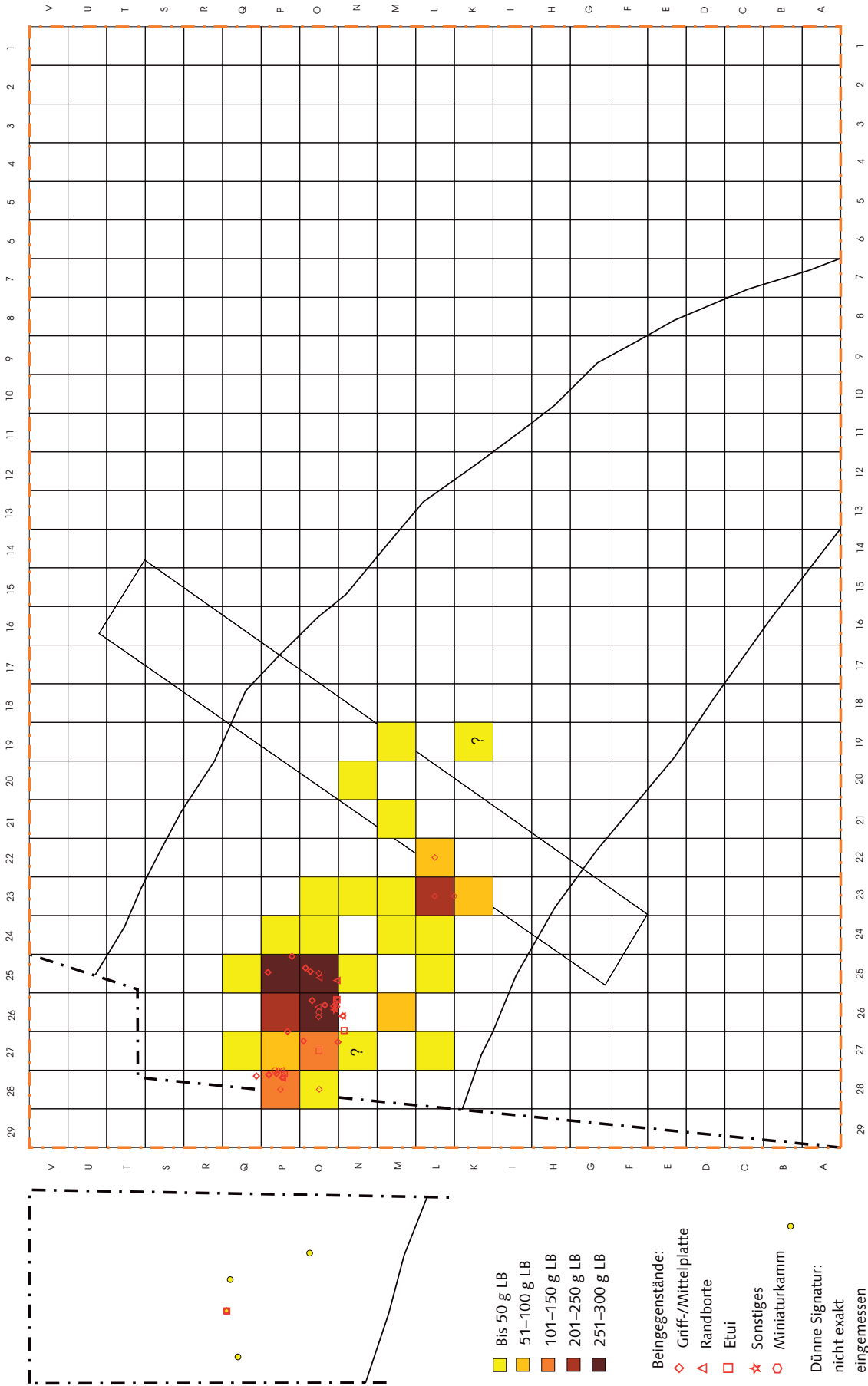

Herzebrock-Clarholz, DKZ 4015,10. Moorsenke F 14. Verteilung des Leichenbrandes nach Gewicht und Verteilung der Beigegenstände. – Maßstab 1:150.

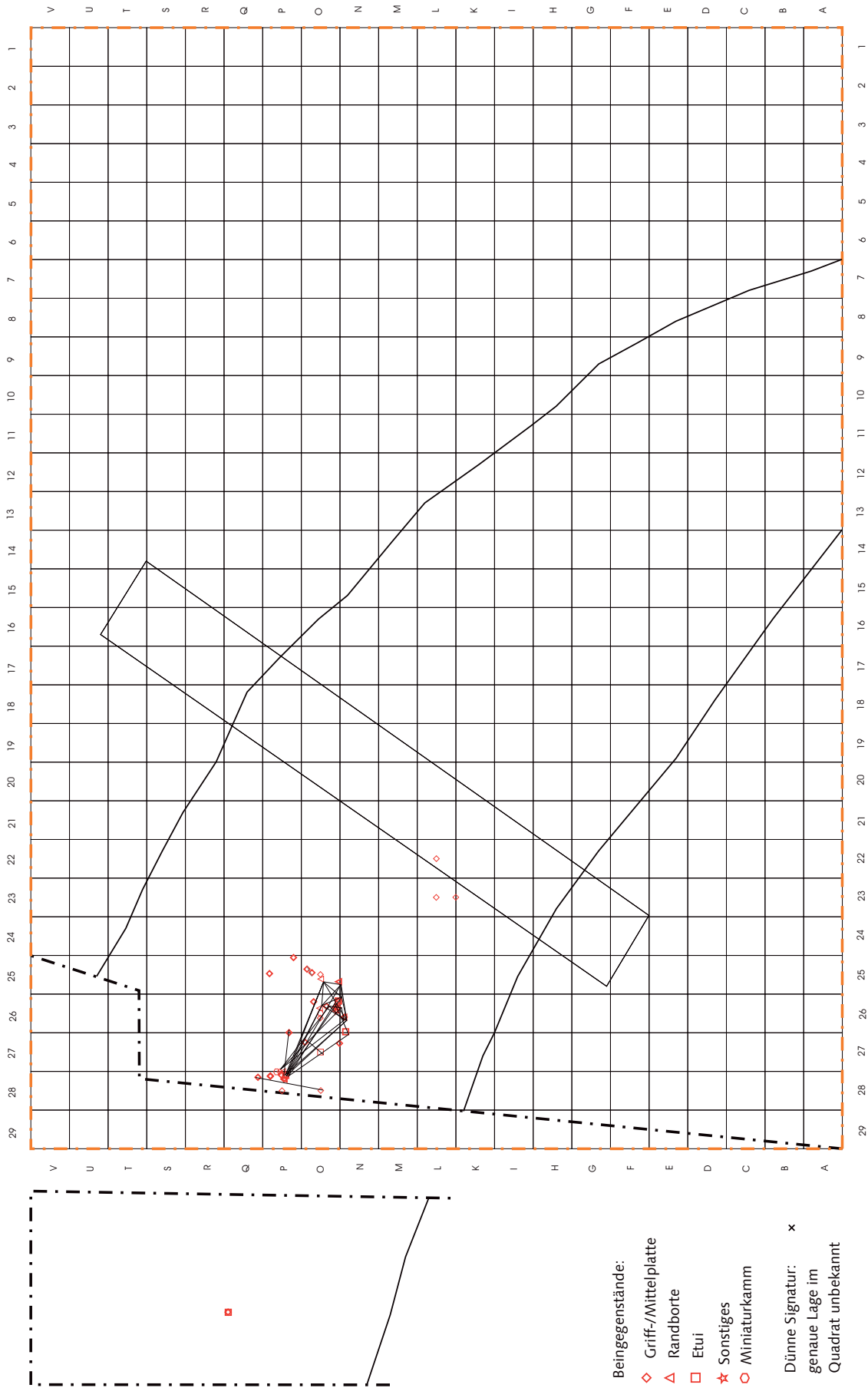

Herzebrock-Clarholz, DKZ 4015,10. Moorsenke F 14. Verteilung von Beigegegenständen, Verbindungen zwischen zum selben Objekt gehörenden Einzelteilen. – Maßstab 1:150.



# Tafel 92

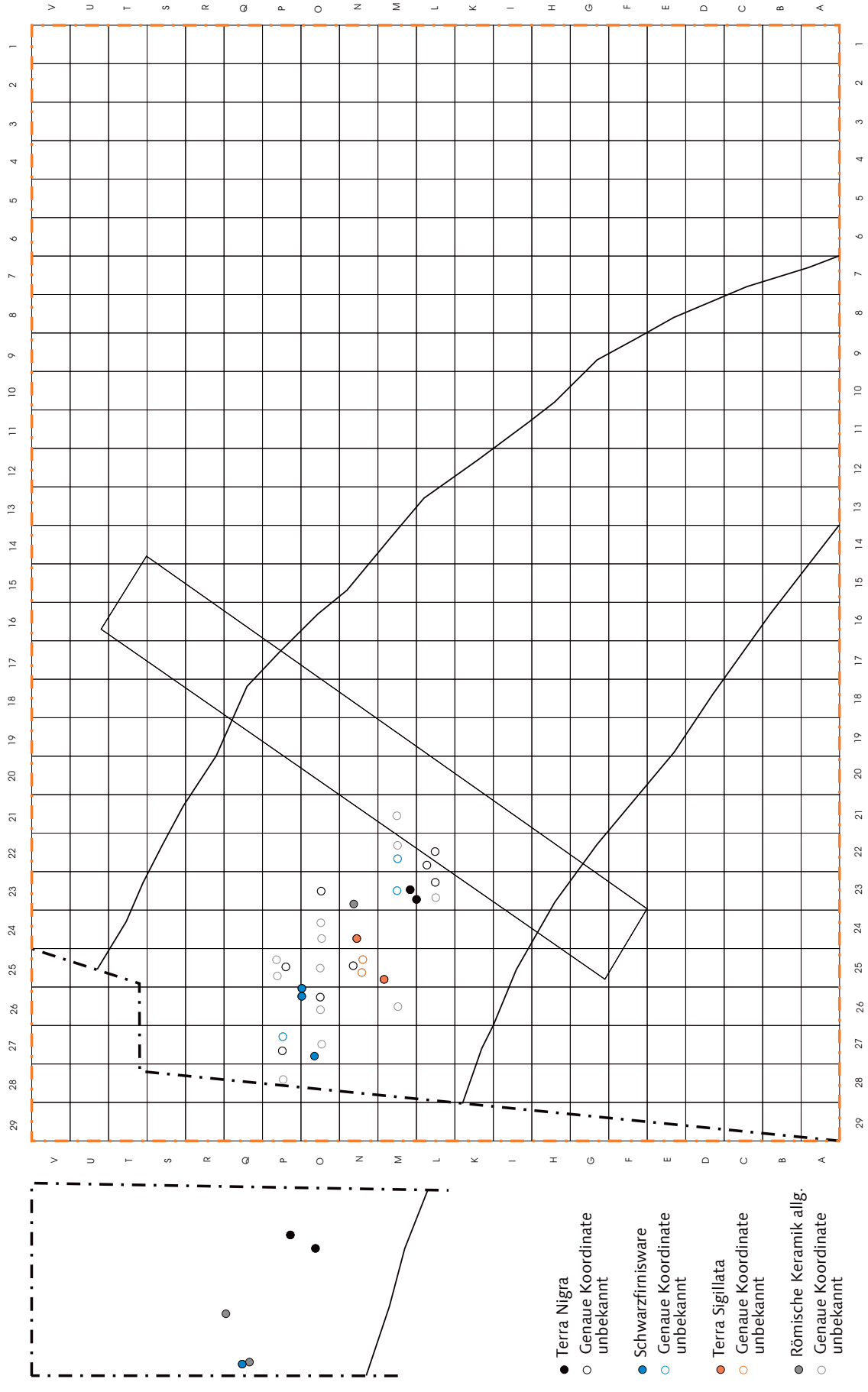

Herzebrock-Clarholz, DKZ 4015,10. Moorsenke F 14. Verteilung der römischen Keramik in der Hauptfundschicht. – Maßstab 1:150.

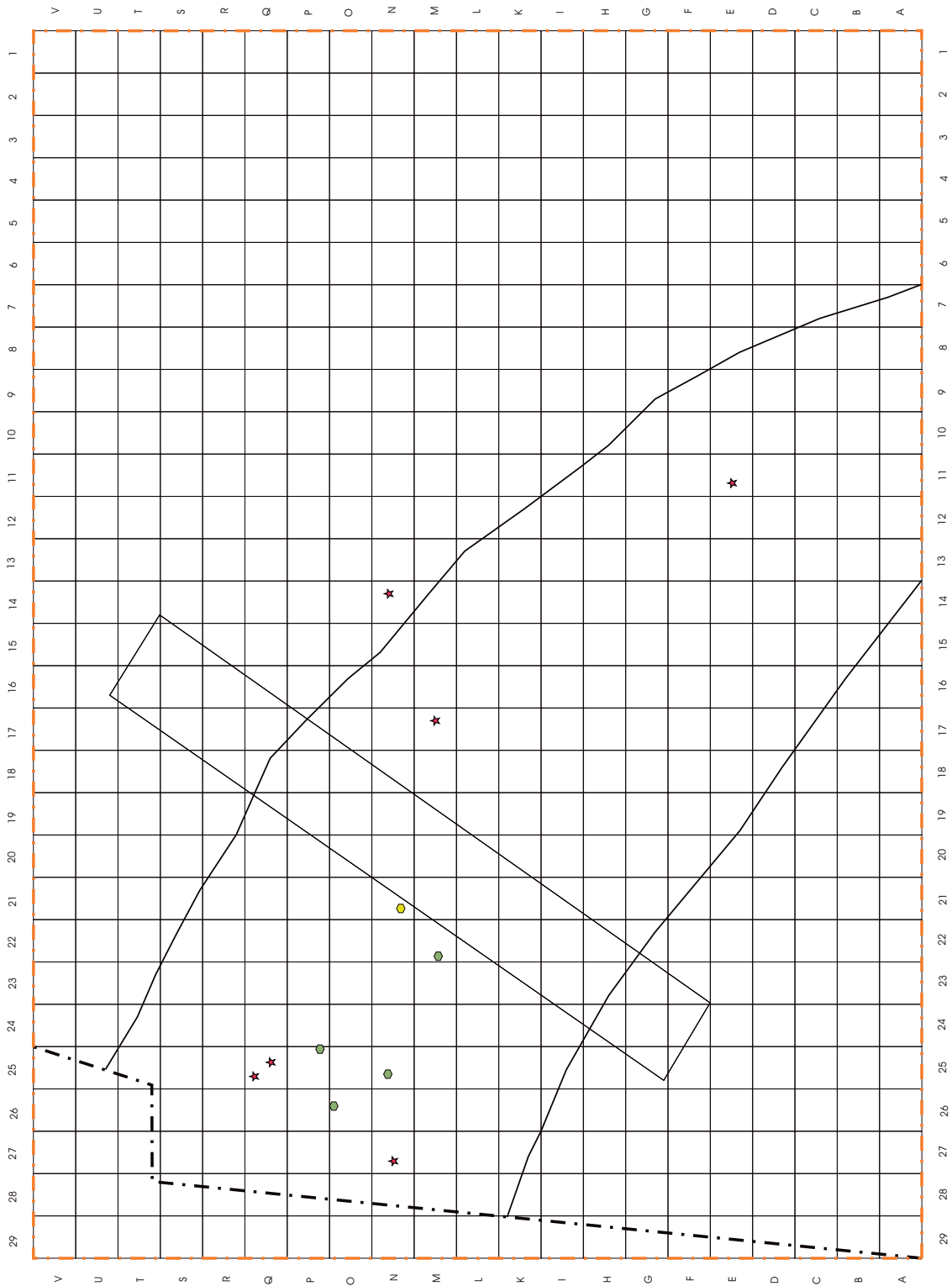

★ Tongewichte  
(Pl. 0, 1, 4, 5)

Planum 3: Metall

● Bronze

● Gold

Herzbrock-Clarholz, DKZ 4015,10. Moorsenke F 14. Verteilung der Tongewichte und Metallgegenstände (Tongewichte nicht alle exakt eingemessen). – Maßstab 1:150.

# Tafel 94

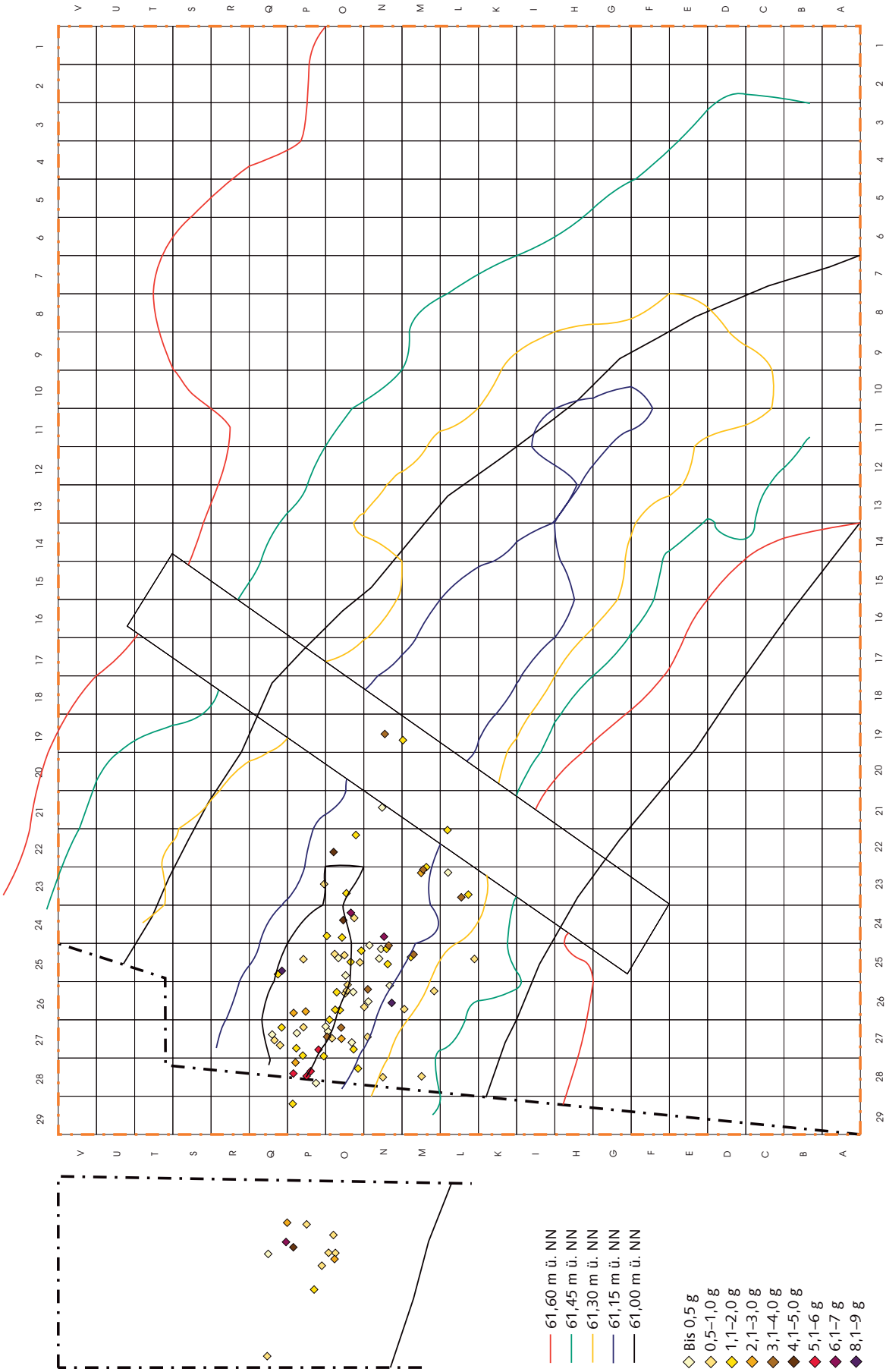

Herzebrock-Clarholz, DKZ 4015,10. Moorsenke F 14. Verteilung der Glasschmelzstücke nach Gewicht (Höhenlinien zur Orientierung entsprechen dem Niveau unter Pl. 3). – Maßstab 1:150.

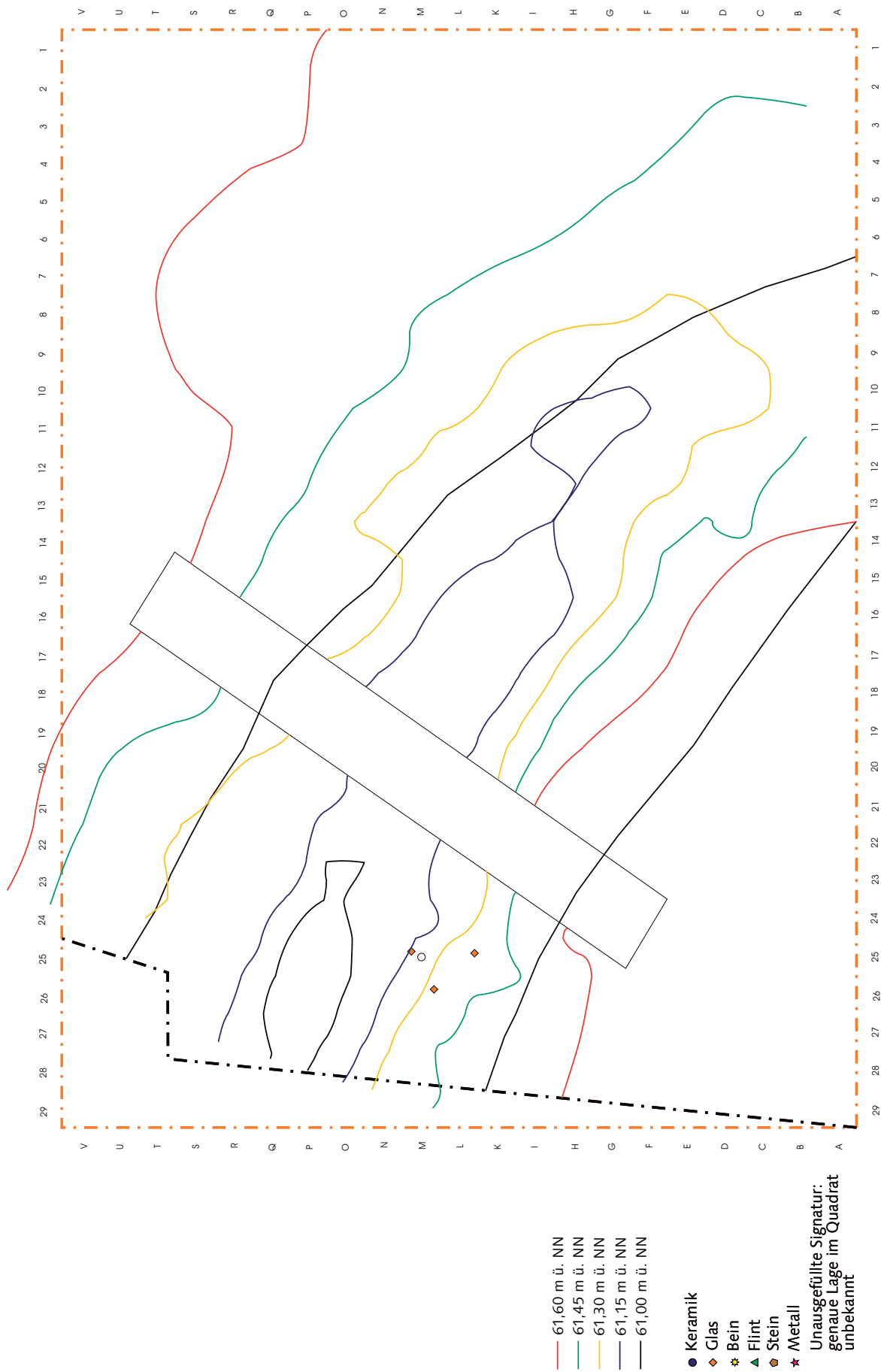

Herzebrock-Clarholz, DKZ 4015,10. Moorsenke F 14. Lage der eingemessenen Funde zwischen 61,50m ü. NN und 61,41 m ü. NN (Höhenlinien zur Orientierung entsprechen dem Niveau unter Pl. 3). – Maßstab 1:150.

# Tafel 96

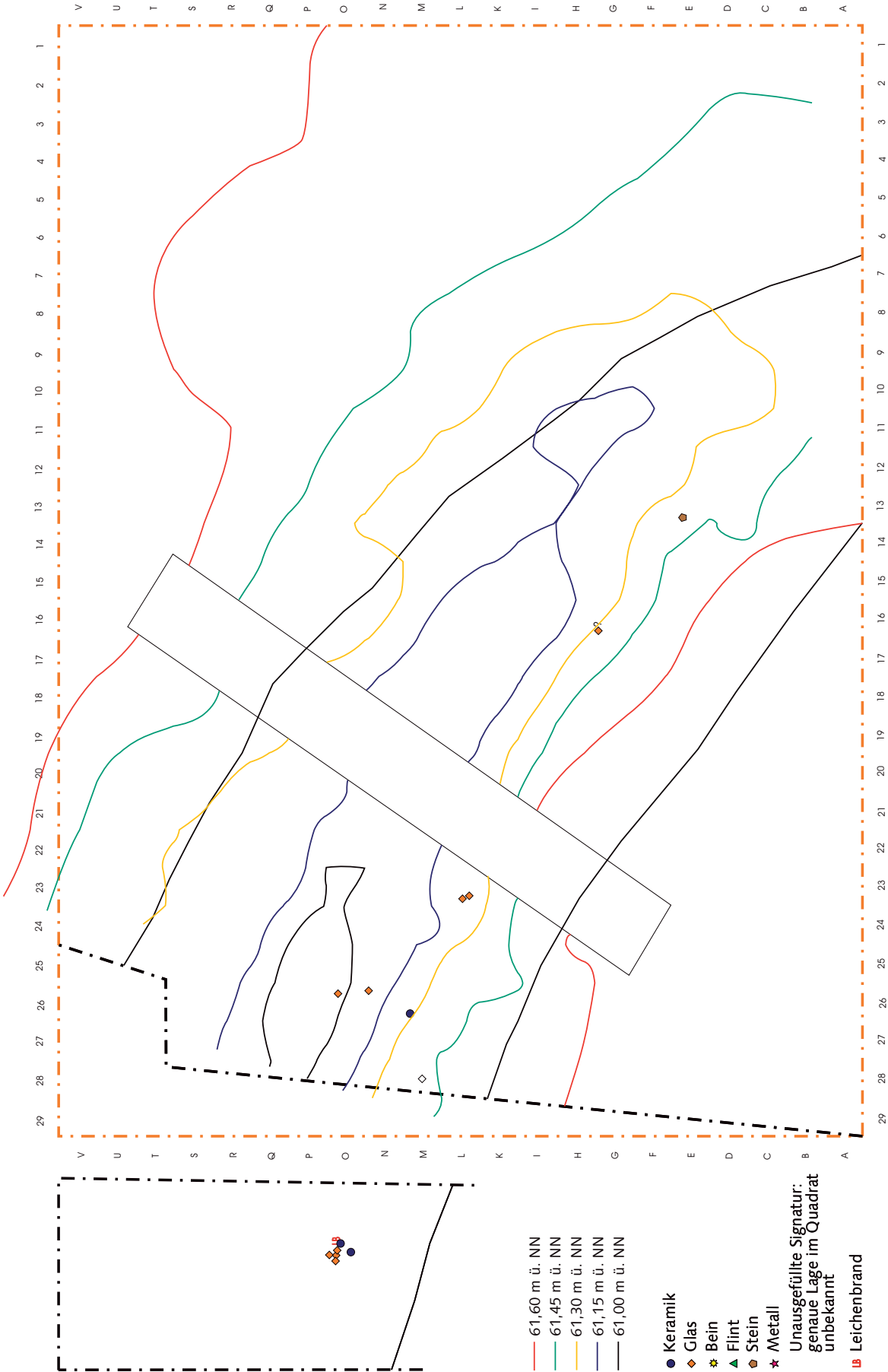

Herzebrock-Clarholz, DKZ 4015,10. Moorsenke F 14. Lage der eingemessenen Funde zwischen 61,40 m ü. NN und 61,31 m ü. NN (Höhenlinien zur Orientierung entsprechen dem Niveau unter Pl. 3). – Maßstab 1:150.

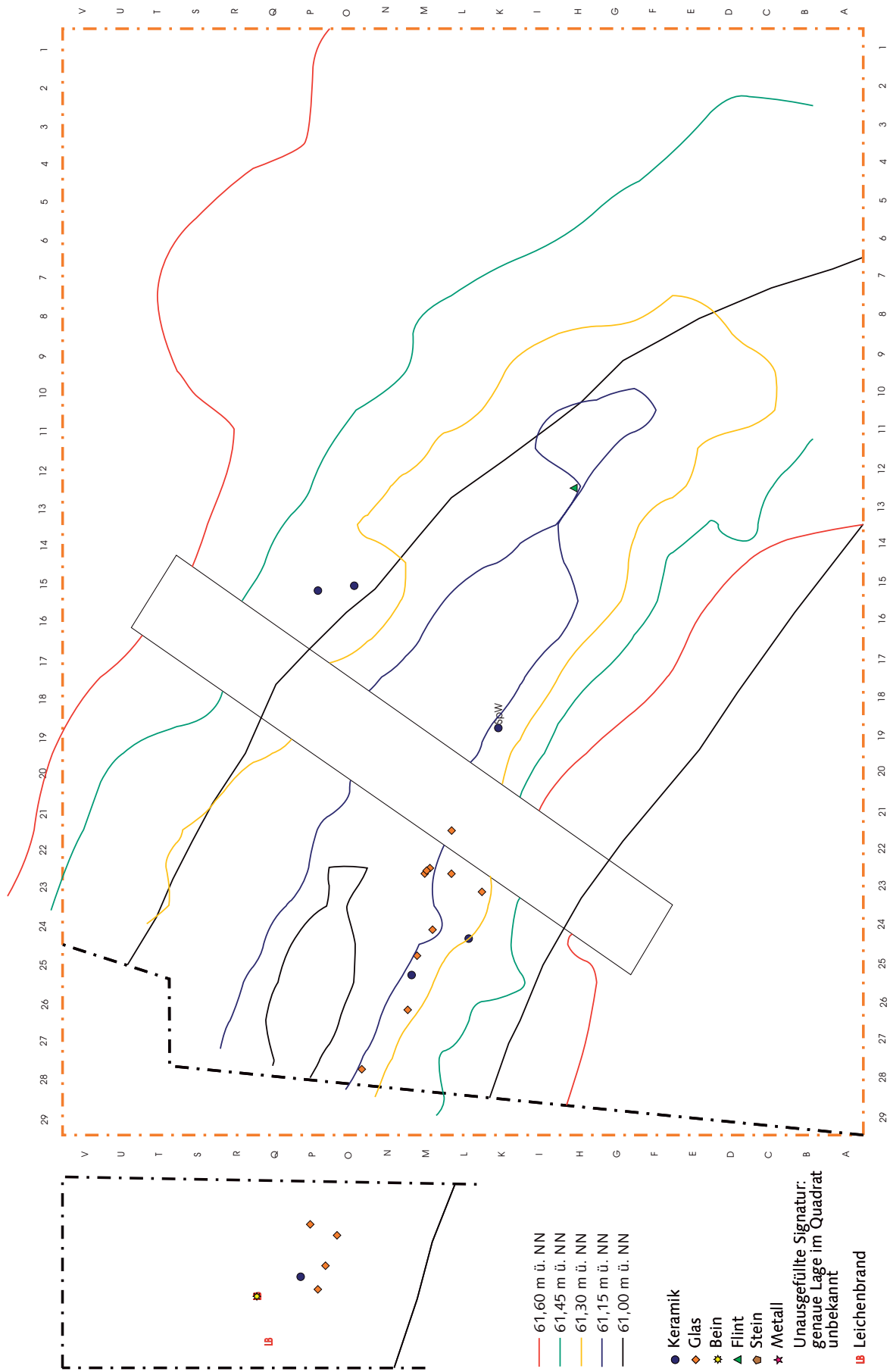

Herzebrock-Clarholz, DKZ 4015,10. Moorsenke F 14. Lage der eingemessenen Funde zwischen 61,30m ü.NN und 61,21 m ü.NN (Höhenlinien zur Orientierung entsprechen dem Niveau unter Pl. 3). – Maßstab 1:150.

# Tafel 98

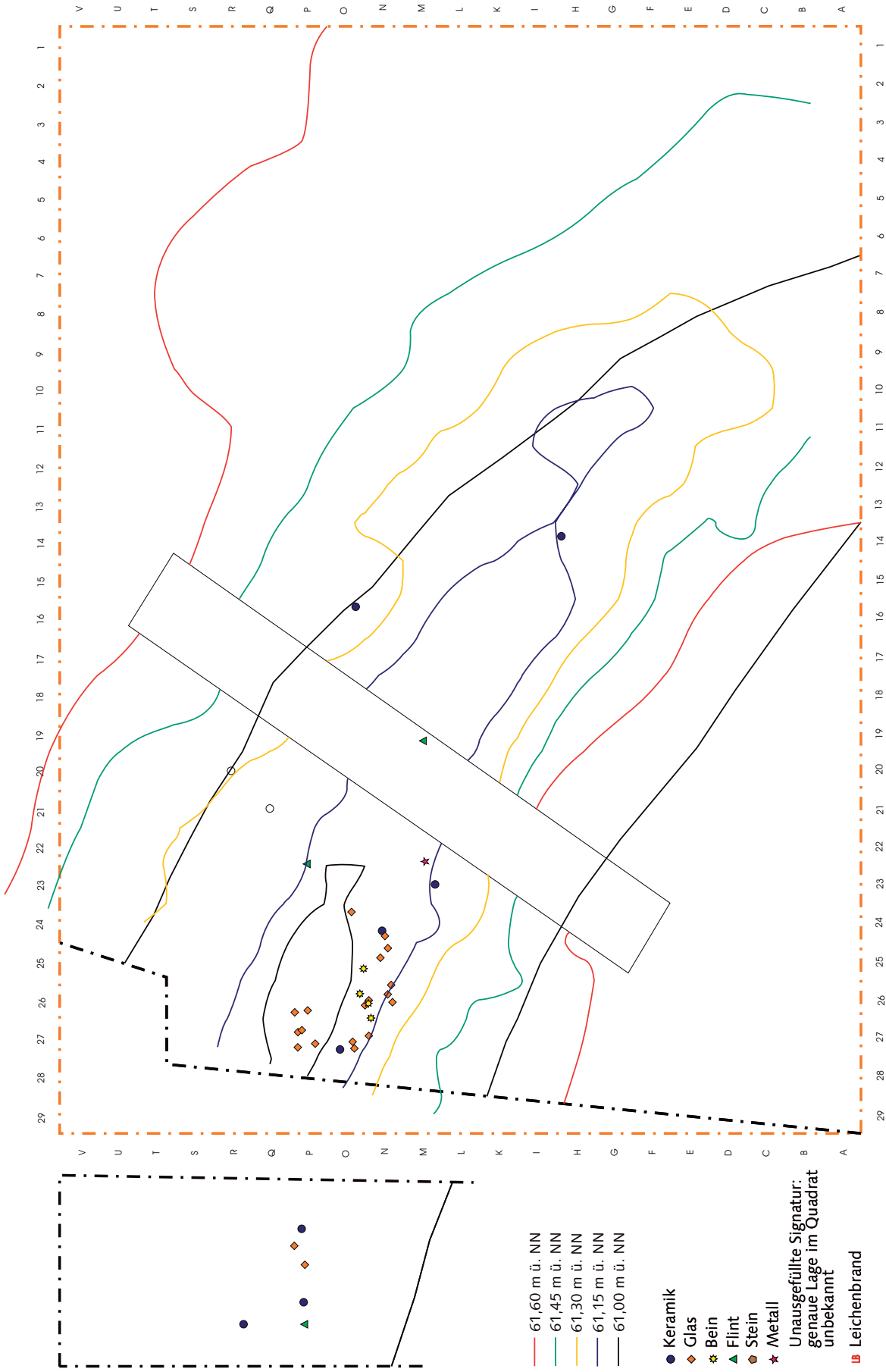

Herzebrock-Clarholz, DKZ 4015,10. Moorsenke F 14. Lage der eingemessenen Funde zwischen 61,20 m ü. NN und 61,11 m ü. NN (Höhenlinien zur Orientierung entsprechen dem Niveau unter Pl. 3). – Maßstab 1:150.



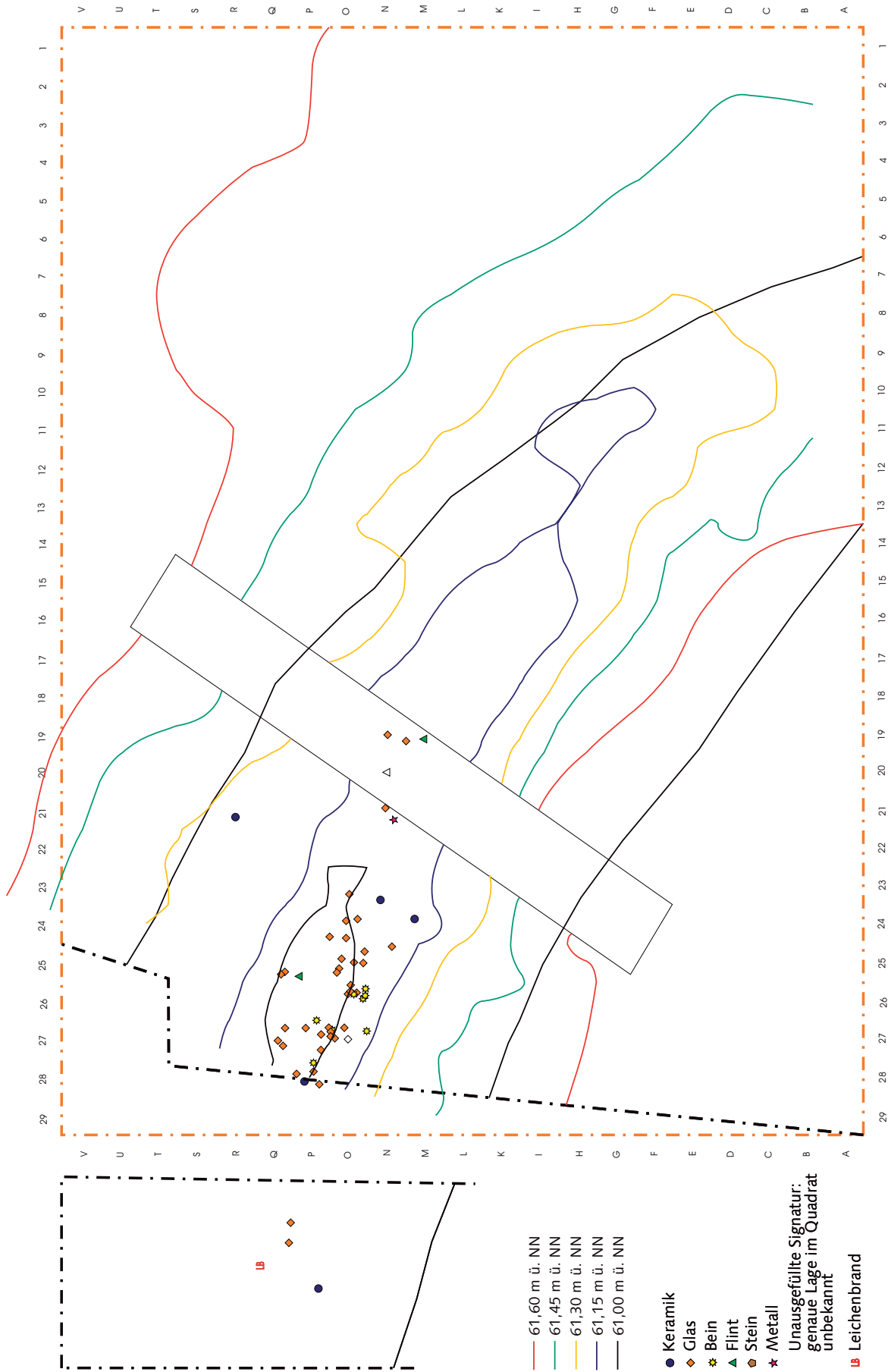

Herzebrock-Clarholz, DKZ 4015,10. Moorsenke F 14. Lage der eingemessenen Funde zwischen 61,00 m ü. NN und 61,01 m ü. NN (Höhenlinien zur Orientierung entsprechen dem Niveau unter Pl. 3). – Maßstab 1:150.

# Tafel 100

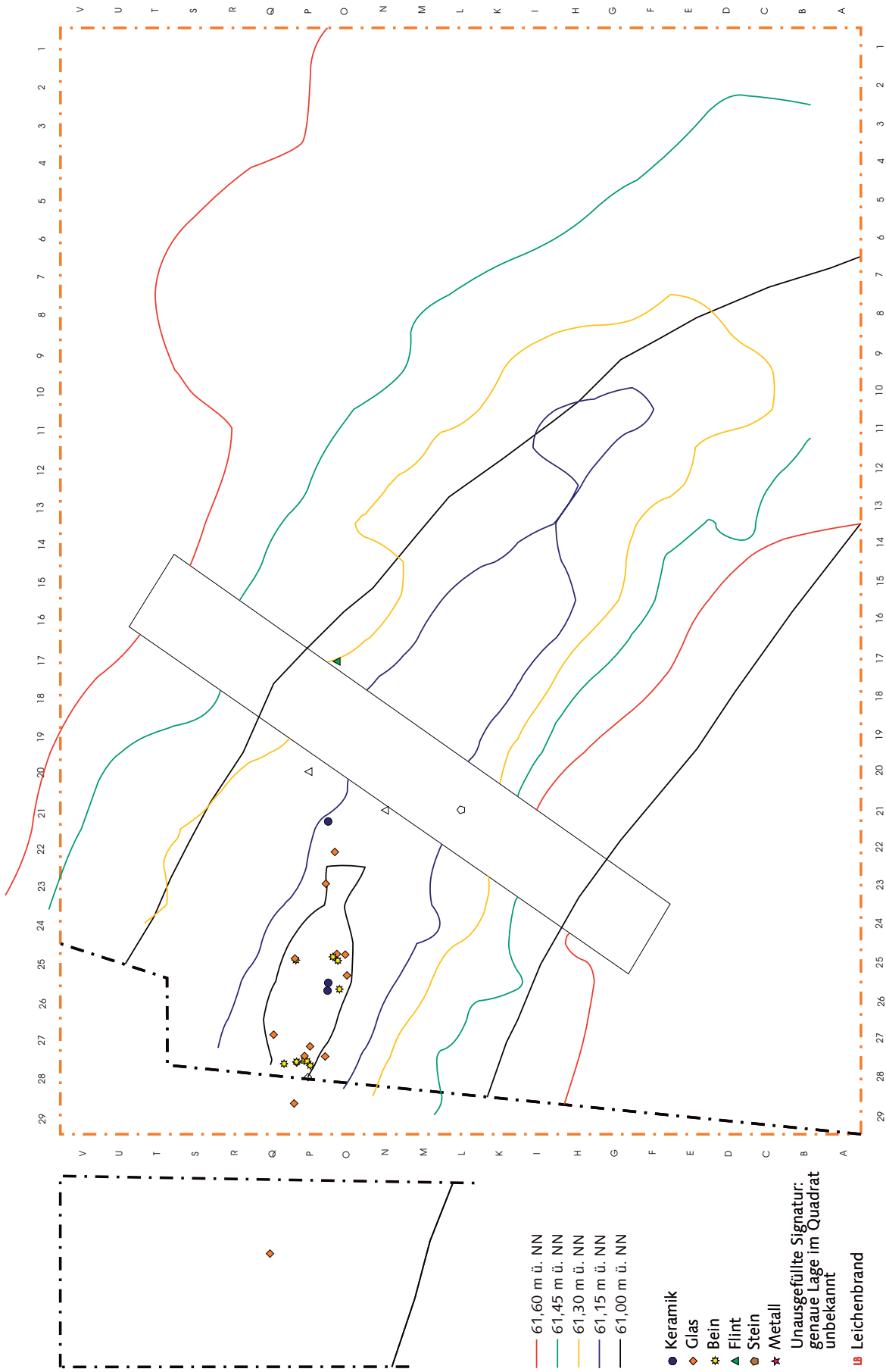

Herzebrock-Clarholz, DKZ 4015,10. Moorsenke F 14. Lage der eingemessenen Funde zwischen 61,00 m ü. NN und 60,91 m ü. NN (Höhenlinien zur Orientierung entsprechen dem Niveau unter Pl. 3). – Maßstab 1:150.